

# OPERATION, SERVICE AND PARTS MANUAL

# TUGIT<sup>®</sup>

# LEVER OPERATED HOISTS

CAPACITY	CATALOG NUMBER (R prefix designates Redline Model)	MODEL NUMBER
1½ Ton	291 R 291	509276 509281
3 Ton	292 R 292	509277 509282
1½ to 3 Ton (Convertible)	293 R 293	509278 509283
4½ Ton	294 R 294	509279 509284
6 Ton	295 R 295	509280 509285

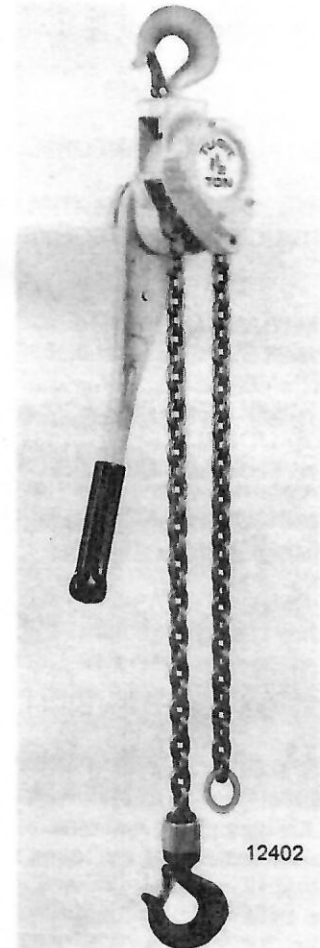

1½ TON MODEL

**LIFTTECH** 

**LIFT-TECH INTERNATIONAL  
CRANE AND HOIST OPERATIONS  
MUSKEGON, MICHIGAN 49443**

**TUGIT**

## FOREWORD

This book is written to assist in operation, maintenance and service for TUGIT Lever Operated Hoists. Study its contents thoroughly before attempting operation. By applying correct operating procedures and practicing the helpful maintenance suggestions, you will be assured optimum performance and service.

It will likely be a long time before you will need the repair and parts information included, so file this book for future reference.

## INDEX

Section	Page
<b>STANDARD MODELS</b>	
I GENERAL DESCRIPTION .....	2
II OPERATION .....	2
III LUBRICATION .....	4
IV MAINTENANCE .....	5
V TROUBLE SHOOTING .....	6
VI DISASSEMBLY & REASSEMBLY .....	7
VII SPECIAL REDLINE INFORMATION .....	11
<b>3 TON CONVERTIBLE MODEL</b>	
VIII INSTRUCTIONS FOR CONVERTING .....	12
<b>PARTS LIST</b>	
IX FRAME AND GEARING .....	14
LOWER BLOCKS FOR 3, 4-1/2 AND 6 TON MODELS .....	16
UPPER BLOCKS FOR 4-1/2 AND 6 TON MODELS .....	17
CONVERTIBLE CONVERSION PARTS .....	18
<b>HOIST HANDLE</b>	
X SERVICE AND PARTS LIST .....	19

## SECTION I — GENERAL DESCRIPTION

1-1. TUGIT Lever Operated Hoists are precision built spur geared type hoists, especially designed for close quarter lifting, pulling and stretching. They are operated by a handle instead of the usual hand chain.

1-2. This book contains operating, service and parts information for 1-1/2, 3, 4-1/2 and 6 ton capacity lever hoists, including convertible models. These hoists are also metric rated: 1-1/2 ton is 1500 kg, 3 ton is 3000 kg, 4-1/2 ton is 4500 kg and 6 ton is 6000 kg. Each size has hook latches as standard. The catalog number and model number of each hoist is found on the nameplate on the TUGIT hoist frame. When ordering parts, always give model and catalog number of hoist. The information contained in Sections I thru VII is also applicable to the 3 ton convertible model covered in Section VIII. **INFORMATION CONTAINED IN THIS BOOK IS SUBJECT TO CHANGE WITHOUT NOTICE.**

1-3. The 1-1/2 and 3 ton capacity TUGIT hoists are basically the same and differ only in hook size and chain reeving. On 1-1/2 ton models the lower hook is suspended on a single part of load chain; two parts on 3 ton model. The 3 ton convertible model has a quick-disconnect dead end chain anchor which facilitates changing from 3 ton double-line to 1-1/2 ton single-line chain reeving (see Section VIII). Frames are aluminum alloy; load chains are welded link type of special calibrated pitch and are heat treated alloy steel; hooks are forged steel, designed to open slowly when overloaded.

1-4. The 4-1/2 and 6 ton TUGIT Lever Operated Hoists are basically the same in design as 1-1/2 and 3 ton model TUGIT hoists. They contain the same aluminum frame, operating handle and internal parts, but employ a special upper hook and block assembly and special lower blocks to accommodate multiple reeving of load chain (3 or 4 parts of chain depending upon capacity).

1-5. TUGIT Redline Lever Operated Hoists are equipped with a Load Regulator which is designed to help guard against excessive overloads. The Redline TUGIT hoists may be identified by their red vinyl handle and by nameplate.

## SECTION II — OPERATION

### 2-1. GENERAL

A TUGIT Lever Hoist is an extremely versatile tool and will perform any number of load handling jobs when operated properly and its features are used to advantage. Operation is easy, once you have become acquainted with its convenient controls and their functions. Always practice hoist safety by applying the rules shown in the safety chart on the inside of the back cover.

### WARNING

This equipment is not designed or suitable as a power source for lifting or lowering persons.

### 2-2. TO RAISE LOAD HOOK

a. Turn finger-tip control lever to "UP" position (hoist must be free of handle loading when turning finger-tip control lever to "UP").

b. Rotate hand wheel counterclockwise, as shown in Figure 2-1.

c. Load can now be raised by working the operating handle.

NOTE: If when working the handle you find pressure is required on the upward stroke, rotate the handle to allow you to pull downward or turn the hoist around so the handle is on the other side. You'll find it's easier when effort is applied in the downward direction.

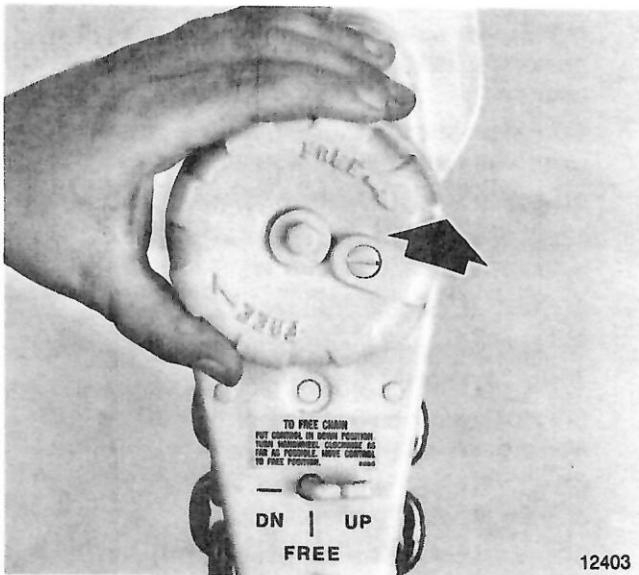

Figure 2-1. Turning Handwheel Counterclockwise, Finger-Tip Lever in "UP" Position

### 2-3. TO LOWER LOAD HOOK

- Turn finger-tip control lever to "DN" position (hoist must be free of handle loading when turning finger-tip control lever to "DN").
- Load hook will now lower as the handle is actuated.

NOTE: On light loads, first turn finger-tip control lever to "UP," actuate handle once or twice to make certain handle engages. Then turn lever to "DN" and operate handle.

### 2-4. TO FREEWHEEL CHAIN

Freewheeling allows the load chain to be quickly pulled thru the hoist without operating the handle.



a. Set finger-tip control lever in "DN" position and turn hand wheel clockwise as far as it will go.

b. Move finger-tip lever to "FREE" position and pull chain thru hoist, Figure 2-2.

### 2-5. "FREEWHEEL" CAUTION

a. Your TUGIT Lever Hoist will not "freewheel" if handle is cocked as shown in Figure 2-3. Make certain there is no side thrust or pressure that would prevent load brake nut from turning freely.

b. If operating handle works in "UP" direction but not in "DOWN" direction, the load brake is locked-up from previous load. This happens when load is removed from hook while hoist is still being used in "UP" direction. To correct this condition, secure the hoist frame and apply pressure to the handle. The brake will then unlock. NOTE: The finger-tip lever must be in the "DN" position.

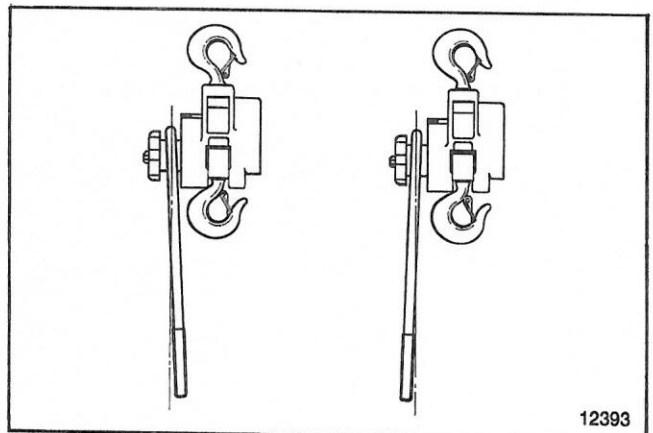

Figure 2-3. Views Showing Operating Handle Cocked

### 2-6. OPERATING PRECAUTIONS

Safe operation of an overhead hoist is the operator's responsibility. Listed below are some basic rules that can make an operator aware of dangerous practices to avoid and precautions to take for his own safety and the safety of others. Observance of these rules in addition to frequent examinations and periodic inspection of the equipment may save injury to personnel and damage to equipment. Also see illustrated operating rules on the inside of the back cover of this manual.

## ⚠ WARNING

Failure to use the hoist properly may result in personal injury and property damage. Proper use of the hoist will include the following rules.

**Do not use extension on handle. Use of an extension will severely overload the hoist and may result in personal injury.**

An average force of 75 pounds applied to the 1-1/2 ton TUGIT lever hoist handle will produce rated load at the load chain. Load sprocket position can cause this handle force to be 85 pounds for a short part of a lift. The average and maximum handle force required to produce rated load are shown in

**Table 2-1. The user is here warned that forces larger than shown in Table 2-1, if placed on the TUGIT lever hoist handle by any means, will result in an overload condition on the hoist. Any such overload will result in a dangerous condition for the user, nearby persons and property.**

**The user is also here warned that overloading of the TUGIT lever hoist can take place by means other than applying a high handle force. Proper rigging and observance of the rules listed here can help avoid such external causes of overload. Use good common sense and judgment at all times.**

Hoist Catalog Number	Hoist Rated Load	Handle Force Required in Pounds to Raise Load	
		Average	Maximum
291	1-1/2 Ton (3000 lb.)	75	85
292 (293)	3 Ton (6000 lb.)	77	87
294	4-1/2 Ton (9000 lb.)	81	92
295	6 Ton (12,000 lb.)	85	97

**Table 2-1. TUGIT Lever Hoist Handle Force**

**DO read the Hoist Manufacturer's Operating and Maintenance Instructions.**

**DO be familiar with operating controls, procedures, and warnings on the unit.**

**DO make sure that the unit is securely attached to a suitable support before applying load.**

**DO maintain firm footing or be otherwise secured when operating unit.**

**DO make sure that load slings or other approved single attachments are properly sized and seated in the hook saddle.**

**DO make sure the hook latches, if used, are closed and not supporting any part of the load.**

**DO make sure that load is free to move and will clear all obstructions.**

**DO take up slack carefully, check load balance, move the load a few inches, and check load holding action before continuing.**

**DO make sure all persons stay clear of the supported load.**

**DO avoid swinging of load or load hook.**

**DO protect load chain from weld spatter or other damaging contaminants.**

**DO avoid lever "fly-back" by keeping a firm grip on the lever until operating stroke is completed and the lever is at rest.**

**DO promptly report any malfunction, unusual performance, or damage of the unit.**

**DO inspect unit regularly, replace damaged or worn parts, and keep appropriate records of maintenance.**

**DO use the Hoist Manufacturer's recommended parts when repairing unit.**

**DO use hook latches wherever possible.**

**DO apply lubricant to load chain as recommended by the Hoist Manufacturer.**

**DO NOT lift or pull more than rated load.**

**DO NOT use the hoist load limiting or warning device to measure the load.**

**DO NOT use damaged unit or unit that is not working correctly.**

**DO NOT use unit with twisted, kinked, damaged, or worn chain.**

**DO NOT apply a load unless chain is properly seated in chain wheel(s).**

**DO NOT use load chain as a sling or wrap load chain around load.**

**DO NOT apply a load if any binding prevents equal loading on all loading supporting chains.**

**DO NOT apply the load to the tip of the hook.**

**DO NOT operate unit when it is restricted from adjusting itself to form a straight line with the direction of loading.**

**DO NOT operate except with hand power.**

**DO NOT permit more than one operator to pull on lever at the same time.**

**DO NOT allow your attention to be diverted from operating the unit.**

**DO NOT operate unit beyond limits of load chain travel.**

**DO NOT attempt to "free-chain" unit with any load applied.**

**DO NOT use hoist to lift, support, or transport people.**

**DO NOT lift loads over people.**

**DO NOT leave a load supported by the unit unattended unless specific precautions have been taken.**

**DO NOT allow unit to be subjected to sharp contact with other units, structures or objects through misuse.**

**DO NOT allow the chain or hook to be used as a ground for welding.**

**DO NOT allow the chain or hook to be touched by a live welding electrode.**

**DO NOT remove or obscure the warnings on the unit.**

**DO NOT adjust or repair a unit unless qualified to perform such maintenance.**

**DO NOT attempt to lengthen the load chain or repair damaged load chain.**

**Never rotate hand grip wheel or put hoist into freewheel when hoist is under load.**

**DO NOT pull on tail chain except when free-wheeling load chain.**

**Be sure lower block is not capsized between strands of chain on 3 thru 6 ton hoists.**

**Never operate hoist with hooks that have opened up. See Figure 4-3.**

**The supporting structure or anchoring means shall have a load rating at least equal to that of the hoist.**

**Hoists shall not be used in locations that will not allow operator movement to be free of the load.**

**Before using the hoist, the operator shall be certain that all personnel in the area are clear of the load.**

### SECTION III — LUBRICATION

#### 3-1. LUBRICATION OF INTERNAL PARTS

All internal operating parts of the TUGIT Lever Operated Hoist that require lubrication are prelubricated at time of assembly by the factory. Periodic greasing only is recommended, and intervals are dependent upon type of service. See Section IV — Maintenance.



**Do Not Oil Load Brake. It is extremely important the load brake friction surfaces be kept free of any oil film, so do not apply oil internally.**

#### 3-2. LUBRICATION OF EXTERNAL PARTS

a. Load chain should always be protected from wear with a light film of grease or oil, especially when subjected to damp or corrosive atmospheres.

b. Lubricate needle bearings in lower block of 3, 4-1/2 and 6 ton models and upper block of 4-1/2 and 6 ton models with a N.L.G.I. EP-2 grade of bearing grease.

c. Lubricate upper and lower hooks at the swivel point with heavy-duty graphite grease periodically, as required.

### SECTION IV — MAINTENANCE

#### 4-1. GENERAL

The following are preventive maintenance steps which should be performed periodically as operating conditions demand. Under most conditions, a yearly maintenance inspection is adequate. The entire hoist should be dismantled and its parts inspected for damage or wear and replaced as necessary. At reassembly, the hoist should be relubricated as outlined in paragraph 6-16. If the hoist has been subjected to extremely adverse conditions, such as excessive dirt, moisture, and misuse by overloading, a more frequent maintenance inspection should be made. Visually check hoist after each use.

#### 4-2. LOAD BRAKE

If load brake shows a tendency to slip or drag, remove brake parts, as outlined in paragraph 6-7, and inspect brake friction surfaces for signs of damage, wear, dirt, or an oil film. Contact surfaces of brake flange, ratchet wheel and nut must be free of excessive scoring and

clean. Faces of friction washers should be lightly wire brushed and buffed. Replace any worn parts. Load brake pawl should also be checked for signs of wear or damage. NOTE: Be sure to keep brake friction surfaces free of oil at reassembly. See paragraph 6-16.

#### 4-3. LOAD CHAIN

TUGIT hoist link type load chain is made of extremely tough, hard alloy steel. However, it should be inspected

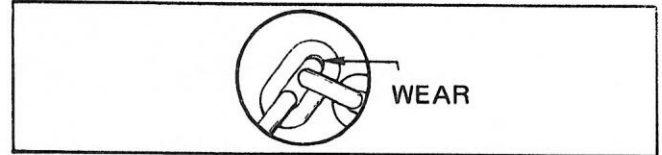

Figure 4-1. Check Chain Wear at Bearing Surfaces Between Links

regularly for wear (see Figure 4-1), rust or corrosion. If the chain has elongated more than as shown in Figure 4-2, it must be replaced. **Never weld or attempt to repair load chain in the field.** Always replace it when damaged or worn using only factory approved chain. Refer to paragraphs 6-3 thru 6-6 and 6-21. The end ring must be in place on the tail end of the chain and it must be circular and not deformed.

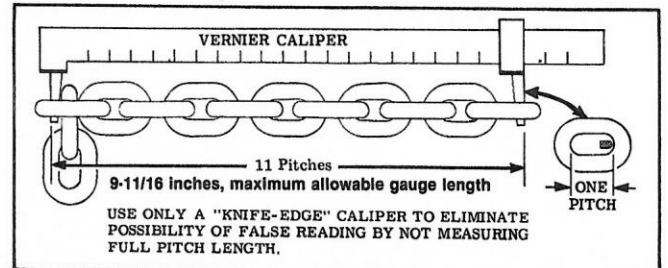
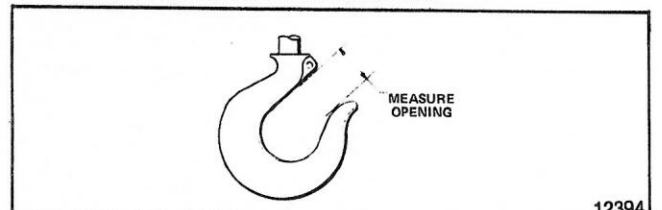

Figure 4-2. Checking Coil Chain Using Vernier Caliper

#### 4-4. HOOKS

Inspect both hooks regularly for evidence of overloading or damage. Check for proper hook opening, Figure 4-3. If hook is opened beyond the given dimension, replace immediately. If hooks are damaged, dismantle hoist and inspect all parts thoroughly. Refer to Section VI for hook removal and installation instructions.



HOIST	HOOK THROAT OPENING	
	Normal Opening	Replace Hook If Opening Is Greater Than
1-1/2 Ton, Upper and Lower Hooks	1-1/4"	1-7/16"
3 Ton, Upper and Lower Hooks	1-3/8"	1-9/16"
4-1/2 Ton, Upper and Lower Hooks	1-3/4"	2"
6 Ton, Upper and Lower Hooks	1-7/8"	2-1/8"

Figure 4-3. Upper and Lower Hook Openings

## SECTION V — TROUBLE SHOOTING

Condition	Probable Cause	Remedy
1. Load Brake Locked-Up. (Handle works in "UP" but not "DOWN".)	1. Load not lowered after hoist was used for lifting.	1. Unlock load brake as outlined in paragraph 2-5, b.
2. Load Brake Slips. (Hoist will not support loads.)	1. Brake friction surfaces coated with oil, or friction washers glazed. 2. Brake parts damaged or worn. 3. Load chain installed backwards.	1. Remove brake parts and clean surfaces. Wire brush friction faces of friction washers and buff or replace. 2. Remove and inspect brake parts. Replace if necessary. 3. Remove and install. See paragraph 6-21.
3. Load Brake Drags. (Handle works hard.)	1. Excessive dirt inside or internal parts corroded. 2. Brake friction surfaces scored or load gearing damaged from overloading.	1. Disassemble and thoroughly clean as outlined in Section VI. 2. Remove and inspect load brake parts and load gearing. Replace damaged or defective parts.
4. Erratic Operation. (Chain gags or jumps in lowering direction.)	1. Load chain installed wrong, welds on links facing sprocket. 2. Load brake pawl or ratchet teeth worn or damaged	1. Remove and reinstall. See paragraph 6-21. 2. Remove load brake parts and inspect pawl and ratchet as outlined in Section VI.
5. Frame Cracked, or Badly Mutilated.	1. Hoist subjected to overloading. 2. Load chain run thru hoist too far, in lowering, causing welded end link to bind against frame. 3. Hoist subjected to extreme angular or side pulls, causing chain to bind on side of frame. 4. Hoist dropped or thrown.	1. Whenever the frame shows evidence of damage from misuse or rough handling, the hoist should be completely dismantled, all parts inspected and damaged or worn parts replaced, as outlined in Section VI. Always apply the safety rules shown on the inside of the back cover when using TUGIT Lever Hoist.
6. Finger-Tip Control Lever Sticks.	1. Dirt inside handle or lack of lubrication.	1. Replace handle or return handle to BUDGIT Hoist Authorized Repair Station for service.
7. Hoist Will Not Freewheel.	1. Improperly operated. 2. Handle cocked when attempting to pull chain thru hoist. 3. Hand wheel not correctly installed.	1. Follow correct operating procedure, Section II. 2. See paragraph 2-5, a. 3. See paragraph 6-20, c.
8. Hooks Opened.	1. Hoist overloaded.	1. Replace hooks. Hoist should be dismantled and thoroughly inspected for additional damage from overloading.

## SECTION VI DISASSEMBLY & REASSEMBLY

### 6-1. DISASSEMBLY

#### 6-2. GENERAL

The following disassembly procedure applies to all hoists except as specifically noted. A complete tear-down procedure is given, however, when servicing specific parts, only a partial teardown may be required.

#### 6-3. REMOVAL OF LOAD CHAIN (1-1/2 Ton Model)

a. To remove hook from end of load chain, remove snap ring at top of sleeve, slide sleeve from body halves and separate parts. See Figure 6-1.

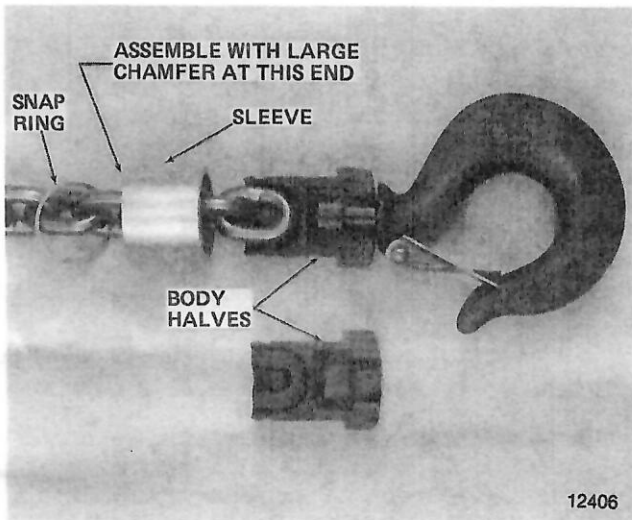

Figure 6-1. Lower Hook Connection — 1-1/2 Ton Model Hoists

b. Place hoist in freewheel position (par. 2-4) and pull out load chain. The round end link on end of chain opposite hook end will not pass thru hoist, so pull hook end thru by tail chain end.

#### 6-4. REMOVAL OF LOAD CHAIN (3 Ton Model)

a. At anchor end of load chain, Figure 6-2, remove set screw and pull out chain anchor pin. A hole is provided

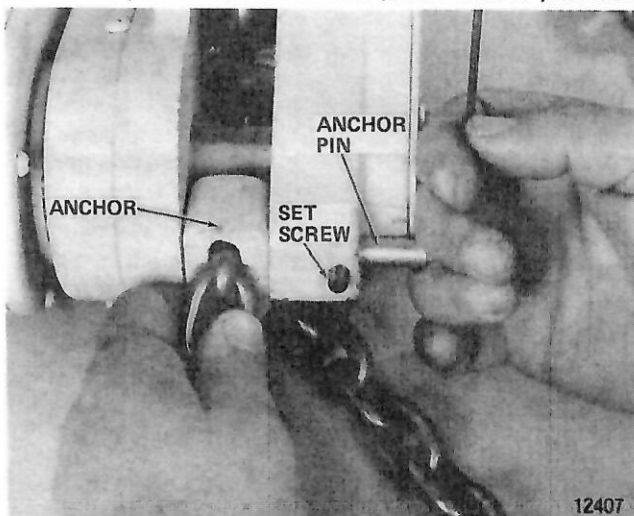

Figure 6-2. Removing Load Chain Anchor Pin using Tool for Pulling

in end of pin to facilitate its removal. When pin is out, the chain and anchor can be lifted out.

b. Remove lower block and hook assembly from load chain and lay to one side for further disassembly.

c. Remove load chain from hoist as outlined in paragraph 6-3, b.

#### 6-5. REMOVAL OF LOAD CHAIN (4-1/2 Ton Model)

At lower block body, drive out spring pin securing chain anchor pin in body using a small drift punch. Spring pin can be driven down into cavity inside body. Remove anchor pin to free dead end of chain. Pull chain free of idler sprockets in upper block and lower block and then remove it from hoist as outlined in paragraph 6-3, b.

#### 6-6. REMOVAL OF LOAD CHAIN (6 Ton Model)

Remove chain anchor from hoist body as outlined in paragraph 6-4, a. Pull chain free of lower block idler sprocket, upper block idler sprocket and the remaining lower block sprocket. Remove chain from hoist as outlined in paragraph 6-3, b.

#### 6-7. REMOVAL OF OPERATING HANDLE AND LOAD BRAKE PARTS

a. Place finger-tip control lever in "DN" position and turn handle counterclockwise to free load brake.

b. Remove bolt and washer securing hand wheel to pinion shaft and lift off hand wheel. See Figure 6-3.

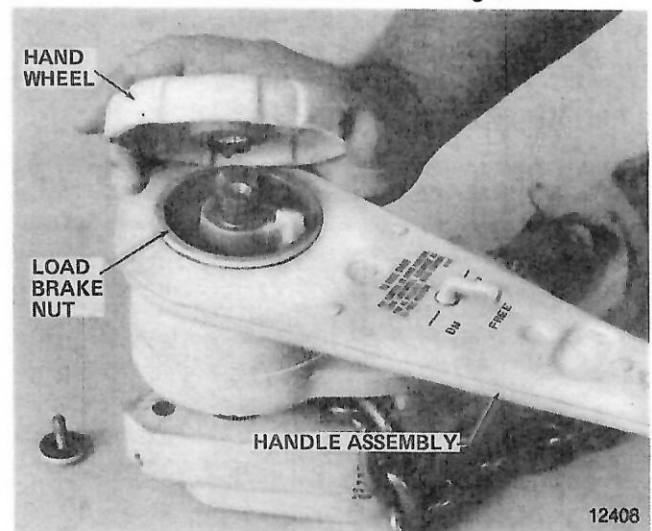

Figure 6-3. Removing Hand Wheel

c. Place control lever in "FREE" position and turn load brake nut in handle counterclockwise until released. Lift off handle and lay aside.

d. Remove 3 pan head screws and lift off load brake cover.

e. Take out load brake parts: two friction washers, brake ratchet, and brake flange. Parts can be removed by turning hoist over and tapping on bench.

f. To remove spring and pawl, slide pawl off shaft. Spring may then be removed.

### 6-8. REMOVAL OF SPRING AND PLUNGER IN HAND WHEEL

Remove plug in hand wheel. This allows spring and plunger to be removed.

### 6-9. REMOVAL OF LOAD GEARING

a. From opposite side of hoist, remove 3 pan head screws and lift off rear cover. If necessary, loosen by tapping with a soft mallet.

b. Remove pinion bearing from pinion shaft and bore in frame. Bearing can be started out of bore by tapping on end of shaft as shown in Figure 6-4.

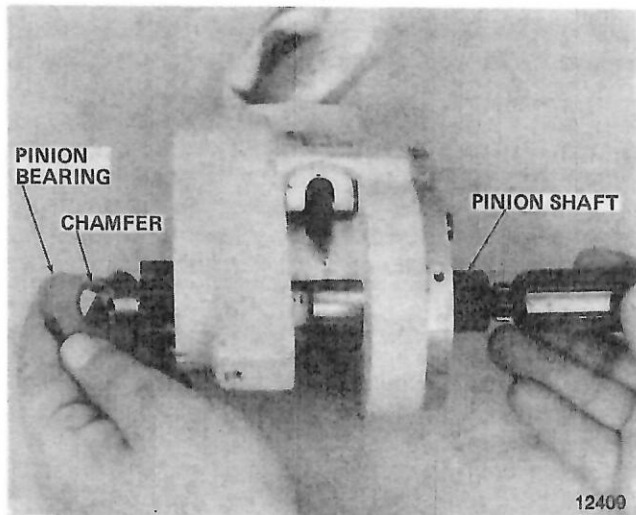

Figure 6-4. Removing Pinion Bearing from Frame and Pinion Shaft

c. Load gearing can now be removed. First lift out chain sprocket with integral gear. Then remove pinion shaft and pinion thrust bearing. The bearing will come out with the shaft and is of special two-piece design for removal from shaft. See Figure 6-5. Separate bearing halves and remove from shaft.

**NOTE:** Do not remove the three bronze bearings from their bores in the frame unless they show evidence of wear or damage and require replacement.

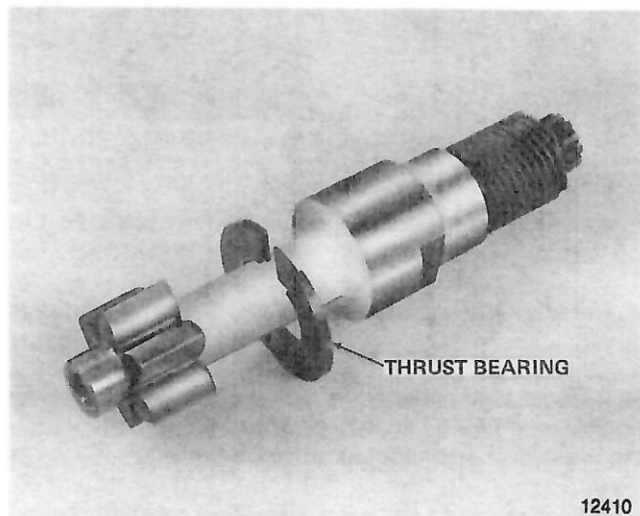

Figure 6-5. Pinion Shaft and Two-Piece Thrust Bearing

d. Remove chain guide from inside frame.

### 6-10. REMOVAL OF UPPER HOOK (1-1/2 & 3 Ton Models)

a. Align grooved pin in hook nut with hole in side of frame and drive out pin with drift punch. If pin is only partially driven out it will serve to hold nut while hook is being unscrewed.

b. Unscrew and remove hook, nut and washer.

**NOTE:** Keep hook and nut together as they are drilled at assembly and are not interchangeable.

### 6-11. REMOVAL OF UPPER BLOCK ASSEMBLY AND UPPER HOOK (4-1/2 & 6 Ton Models)

a. Remove complete assembly from hoist frame as follows:

- (1) Align small end of taper grooved pin in hanger bolt nut with hole in side of hoist frame by rotating bolt and nut. Drive pin free of bolt and nut using a drift punch.
- (2) Unscrew bolt from round nut using screwdriver inserted into key slot on head of bolt. Hold nut from rotating by placing punch in grooved pin hole.
- (3) Separate bracket assembly, hanger bolt, nut and machinery bushing from hoist.

b. Remove upper hook from upper block bracket as follows:

- (1) Align grooved pin in hook nut with hole in bracket and drive out with drift punch.
- (2) Unscrew and remove hook and nut from bracket.

**NOTE:** Keep hook nut with hook and hanger bolt nut with bolt as they are drilled at assembly and are not interchangeable.

c. Remove upper block idler sprocket as follows:

- (1) Remove retaining ring from one end of sprocket shaft.
- (2) Press shaft from bracket and lift out sprocket and 2 washers.
- (3) Do not remove needle bearings from sprocket unless worn or damaged and replacement is necessary.

**NOTE:** If sprocket shaft is rusted or corroded in place, apply penetrating oil and press out using an arbor press.

### 6-12. DISASSEMBLY OF LOWER BLOCK

a. Using a short length of 1/8 inch drill rod, or suitable drift punch, drive spring pin from one end of sprocket shaft in lower block.

b. Press shaft from block and remove sprocket and 2 washers (2 sprockets and 4 washers on 6 Ton Model).

**NOTE:** Do not remove needle bearings from idler sprockets unless they are worn or damaged and replacement is required.

c. Align grooved pin in hook nut with hole in block body and drive out pin with a drift punch. See Figure 6-6.

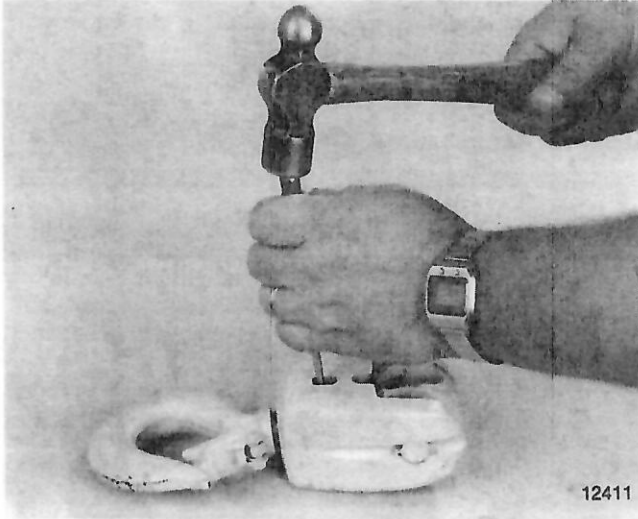

Figure 6-6. Driving Grooved Pin from Hook Nut

d. Unscrew and remove hook, nut and thrust washer.

**NOTE:** Keep hook and nut together as they are drilled at assembly and are not interchangeable.

### 6-13. REASSEMBLY

#### 6-14. GENERAL

The procedure to be followed for reassembly is in reverse order of the disassembly steps outlined above. There are, however, certain precautionary steps that must be taken, as outlined in paragraphs 6-15 thru 6-21 below.

#### 6-15. CLEANING AND INSPECTION OF PARTS

a. Before assembly, all parts should be thoroughly cleaned and inspected to determine their serviceability.

b. Replace parts that are excessively worn or damaged.

#### 6-16. LUBRICATION OF PARTS

a. Lubricate upper and lower hooks with heavy-duty graphite grease. Apply on hook shanks and surfaces between hook, frame, washer and nut. On lower blocks, apply a good grade of bearing grease to needle bearings in sprockets.

b. Lubricate gearing with a N.L.G.I. EP-2 grease. Apply a light film of EP-2 grease to sprocket bearing surfaces and sprocket bushings. Apply a light film of EP-2 grease to the pinion bearing surfaces, bushings and thrust washer assembly. Lubricate load brake pawl with a small amount of EP-2 grease at support pin and ratchet

engagement tip. To make sure that the load brake friction surfaces do not become greased, do not lubricate the ratchet bearing surface or the load brake threads on the pinion shaft. For lubrication of the load brake threads, apply a small amount of EP-2 grease on the leading internal threads of the load brake nut which is part of the handle assembly. When the load brake nut is assembled to the pinion shaft any excess grease will be brought to the end of the pinion shaft where it can be wiped off.

### **! WARNING**

**It is extremely important that load brake friction surfaces be kept dry, as an oily film may cause slippage, thereby permitting a load to drop.**

c. Load chain should be lubricated with a light film of graphite suspension oil. It is important that the bearing surfaces between the links are lubricated. Note Figure 4-1.

### 6-17. ASSEMBLY OF LOWER BLOCKS

When installing lower hook be certain original nut is used. Also, nut must be positioned as shown in Figure 6-7. The nut side with the greater distance to center of hole should face the hook. When installing sleeve on 1-1/2 ton model, be certain large chamfer in one end is positioned as noted in Figure 6-1.

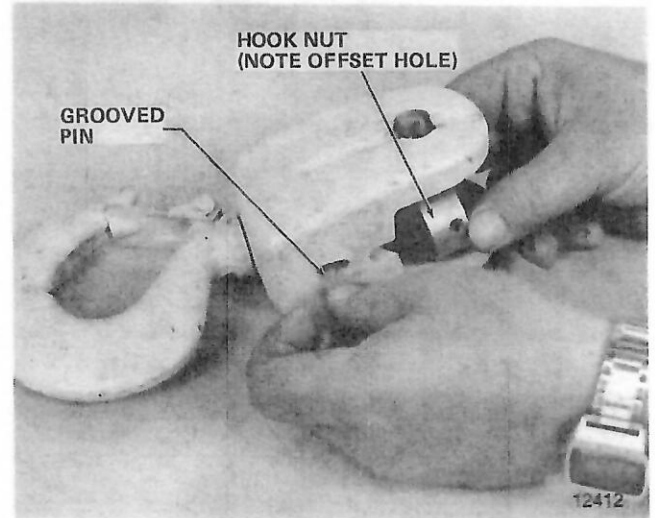

Figure 6-7. Installing Hook and Nut in Lower Block

### 6-18. INSTALLING UPPER HOOKS

Instructions for installing lower hook and nut given in paragraph 6-17 also apply to upper hook and nut.

### 6-19. INSTALLING LOAD GEARING

a. Before load gearing is installed, be certain chain guide is properly seated in frame.

b. When installing pinion bearing, be certain to position it so chamfer in bore faces the pinion gear. See Figure 6-4. The flat on side of bearing must be perfectly aligned with cover pilot bore in frame, as shown in Figure 6-8. Sequence of assembly is: pinion, sprocket, then pinion bearing.

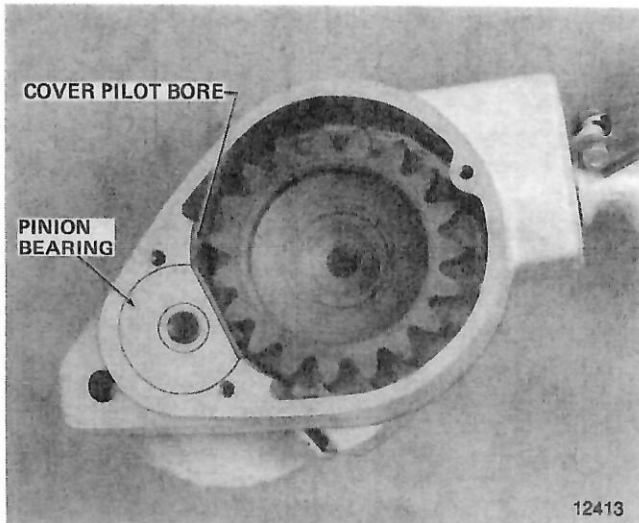

Figure 6-8. Positioning of Pinion Bearing

### 6-20. INSTALLATION OF LOAD BRAKE PARTS

a. Flange goes on first, then friction washer, then ratchet, then 2nd friction washer. Pawl is then installed last. See Figure 6-9. Attach cover with 3 screws.

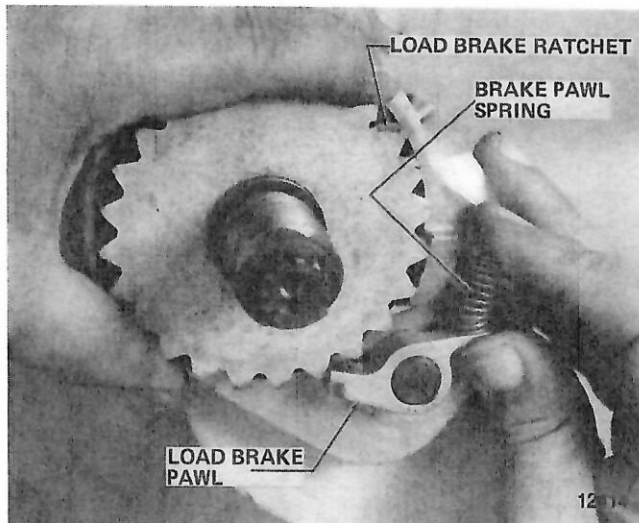

Figure 6-9. Installing Load Brake Ratchet

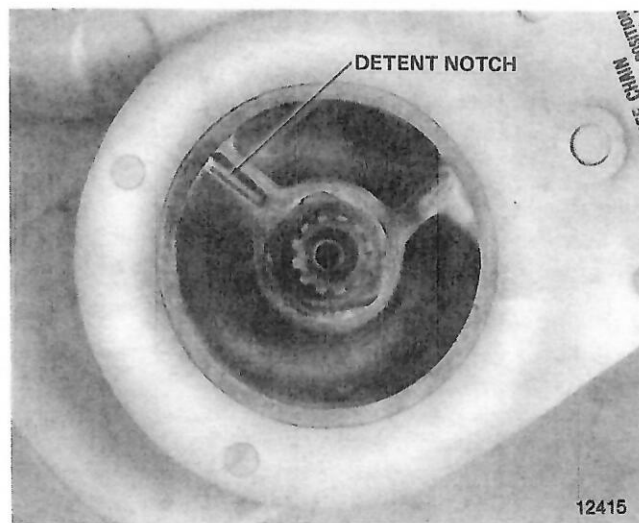



Figure 6-10. View Showing Detent Notch in Load Brake Nut

b. Install handle with load brake nut on pinion shaft, turn nut clockwise thru several clicks of the brake pawl to bring brake friction surfaces into contact before hand wheel is installed. Lube should be in nut threads so that excess is wiped out, not in.

c. Install hand wheel with plunger at least one full spline, but not more than 1-1/2 splines, counterclockwise from detent notch in load brake nut. If properly assembled, the hand wheel will require slight effort to put into the freewheel position (plunger in detent notch) easily; but some effort will be required for it to come out of freewheel. See Figure 6-10.

### 6-21. INSTALLING LOAD CHAIN

 <b>WARNING</b>
<p>When installing load chain it is possible to feed it into the wrong side of hoist, which will result in a reversed hoist action and the load brake will not function.</p>

a. Lay hoist on work bench in the position shown in Figure 6-11, hand wheel side at your right. Then with control lever in "FREE" position, run chain thru, using hand wheel. Be sure welded side of chain links face up so they do not enter chain pockets in sprocket, and chain is not twisted.

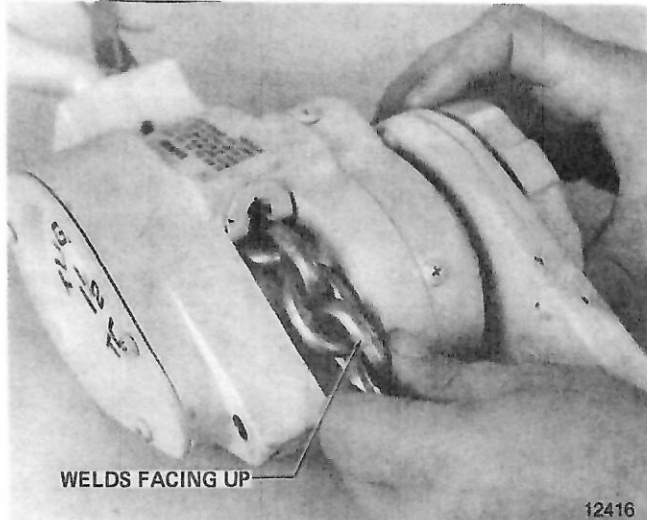

Figure 6-11. Installing Load Chain

b. For proper reeving, see Figure 6-12.

c. On 1-1/2 ton models, pull approximately 3 feet of chain thru hoist and attach lower hook.

d. On other models pull approximately 3 feet of chain thru hoist and reeve thru lower block and upper block sprockets according to the diagram applicable to the capacity of your hoist. Be certain there is absolutely no twist in chain.

e. On 3 and 6 ton models, attach anchor end of chain to anchor yoke at lower end of frame using chain anchor pin and set screw.

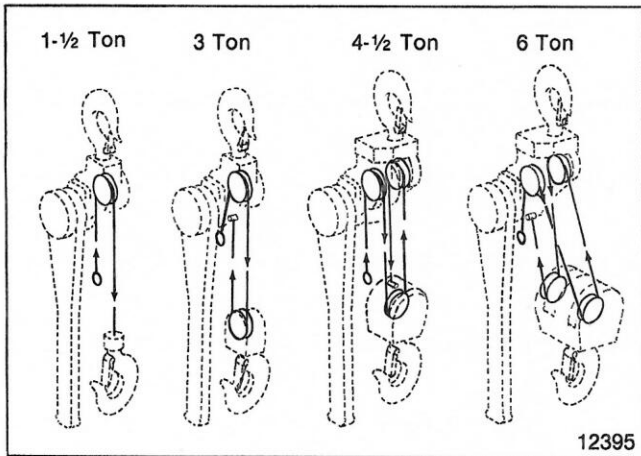

Figure 6-12. Reeving

f. On 4-1/2 ton models, insert anchor end of chain into position in lower block body and install chain anchor pin. Secure in body with spring pin.

g. If end link requires replacement, replace per Figure 6-13.

h. Check operation of hoist at no load, partial load and rated load.

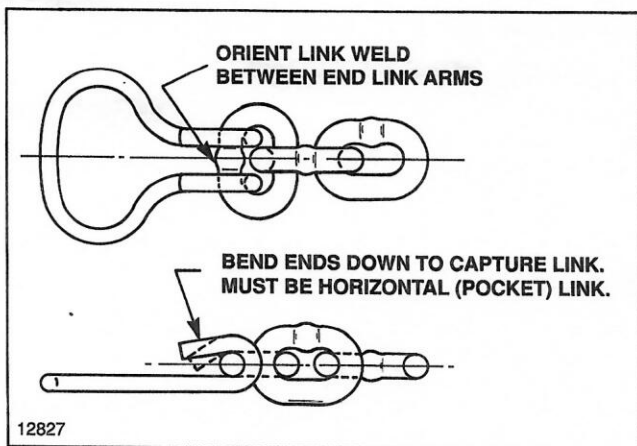

Figure 6-13. Retaining Ring

**IMPORTANT:** After completion of reassembly and before being placed in service, the TUGIT hoist should be tested with rated load to insure safe operation.

## SECTION VII SPECIAL REDLINE INFORMATION

### 7-1. GENERAL

a. TUGIT Lever Operated Hoists having a red vinyl coated handle are equipped with a Load Regulator which is designed to help guard against excessive overloads.

b. The Load Regulator is preset at the factory. If a TUGIT hoist is subjected to overload, the Load Regulator unit will allow the handle to turn without increasing the load

on the hoist. This slippage will occur at a handle force greater than required for rated load and the normal ratcheting sound during the "UP" stroke will not be heard. When this condition occurs, the hoist will continue to support the overload, however, **the overload must be released as soon as possible.** Normal operating procedure is to be followed by turning the finger-tip control to "DN" position and ratcheting the handle.

c. Testing of TUGIT hoist with Load Regulator is recommended at regular intervals which should be determined by amount and conditions of use.

### 7-2. TEST PROCEDURE

a. Suspend hoist by its upper hook from an overhead structure capable of supporting several times rated load of the hoist. Position hoist so that all parts of hoist as well as test load, when suspended on load hook, are free of obstructions. Attach the load hook to a test load equal to the rated load of the hoist. Operate handle to lift the load. If handle slippage occurs and rated load cannot be lifted, Load Regulator may require adjustment (see ADJUSTMENT Section) or the Regulator may be worn from use and require replacement. Service is available from BUDGIT Hoist Authorized Repair Stations.

b. If hoist operates properly with rated load on hook, it should next be tested with a load equal to two times rated load. With this overload attached to load hook, complete slippage of handle should occur. If handle does not slip, Load Regulator may require adjustment (see ADJUSTMENT Section) or may require replacement which is available from any Authorized Repair Station.

c. Replacement of the Load Regulator in the handle must be done by an Authorized Repair Station. Alternatively, a new handle, including Load Regulator, may be obtained from an Authorized Repair Station.

### 7-3. LOAD REGULATOR ADJUSTMENT

a. Remove hand wheel per instructions in paragraph 6-7 of this Manual. This exposes Load Regulator for adjustment as shown in Figure 7-1.

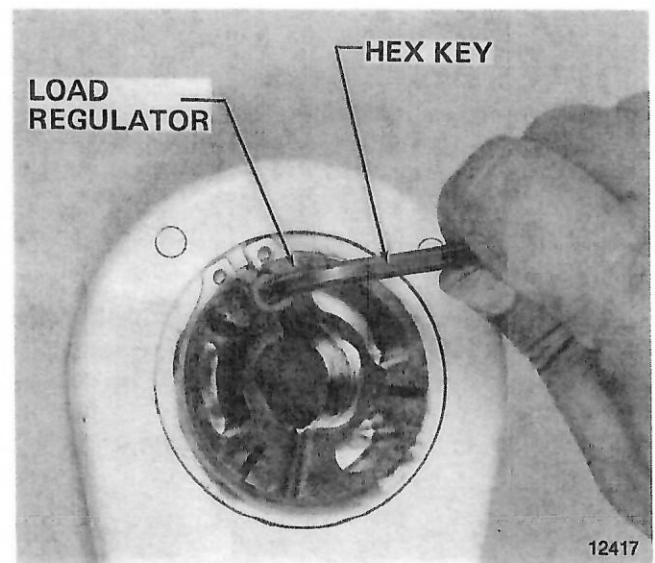

Figure 7-1. Load Regulator

b. **To Increase Load Regulator Capacity** — Insert 3/16" hex key into adjusting screw and tighten clockwise NOT MORE THAN 1/4 TURN. Reassemble hoist and check performance according to recommended TEST PROCEDURE.

NOTE: If adjusting screw cannot be tightened to allow hoist to lift the rated capacity, consult an Authorized Repair Station.

c. **To Decrease Load Regulator Capacity** — With hand wheel, handle and handle thrust washer removed, insert 3/16" hex key into adjusting screw and loosen counter-clockwise NOT MORE THAN 1/8 TURN. Reassemble and check hoist per recommended TEST PROCEDURE.

## SECTION VIII INSTRUCTIONS FOR CONVERTING 3 TON CONVERTIBLE MODEL

### 8-1. GENERAL

The 3 ton TUGIT Lever Operated Hoist Convertible Model is similar to standard 3 ton models except for a Quick Disconnect Chain Anchor Fitting. This special fitting makes it possible to convert the 3 ton Double Line Model (Figure 8-1) to a 1-1/2 ton Single Line Model (Figure 8-2) in a matter of seconds without the use of tools.

### 8-2. INSTRUCTIONS

a. To convert hoist from 3 ton Double Line to 1-1/2 ton Single Line, position hoist as shown in Figure 8-3.

b. Depress and hold Release Pin and withdraw Frame Anchor Pin as shown in Figure 8-4.

c. Withdraw Quick Disconnect Fitting and reinstall Frame Anchor Pin as shown in Figure 8-5.

NOTE: To convert a hoist from 1-1/2 ton Single Line to a 3 ton Double Line merely reverse the above procedure.



Figure 8-1.  
3 Ton Double Line  
Convertible Model

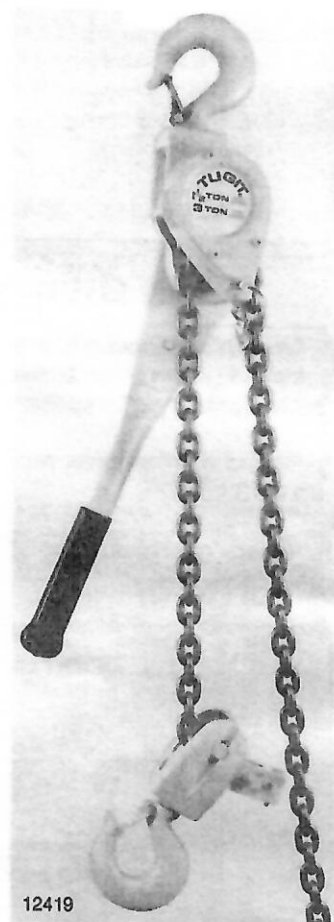

Figure 8-2.  
Converted to 1-1/2 Ton  
Single Line Model



Figure 8-3.

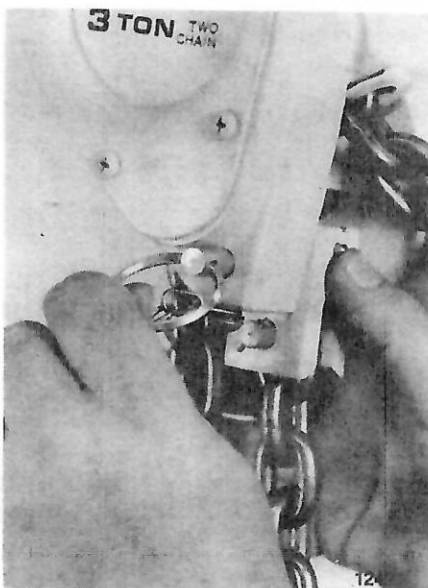

Figure 8-4.



Figure 8-5.



SECTION IX – PARTS LISTS

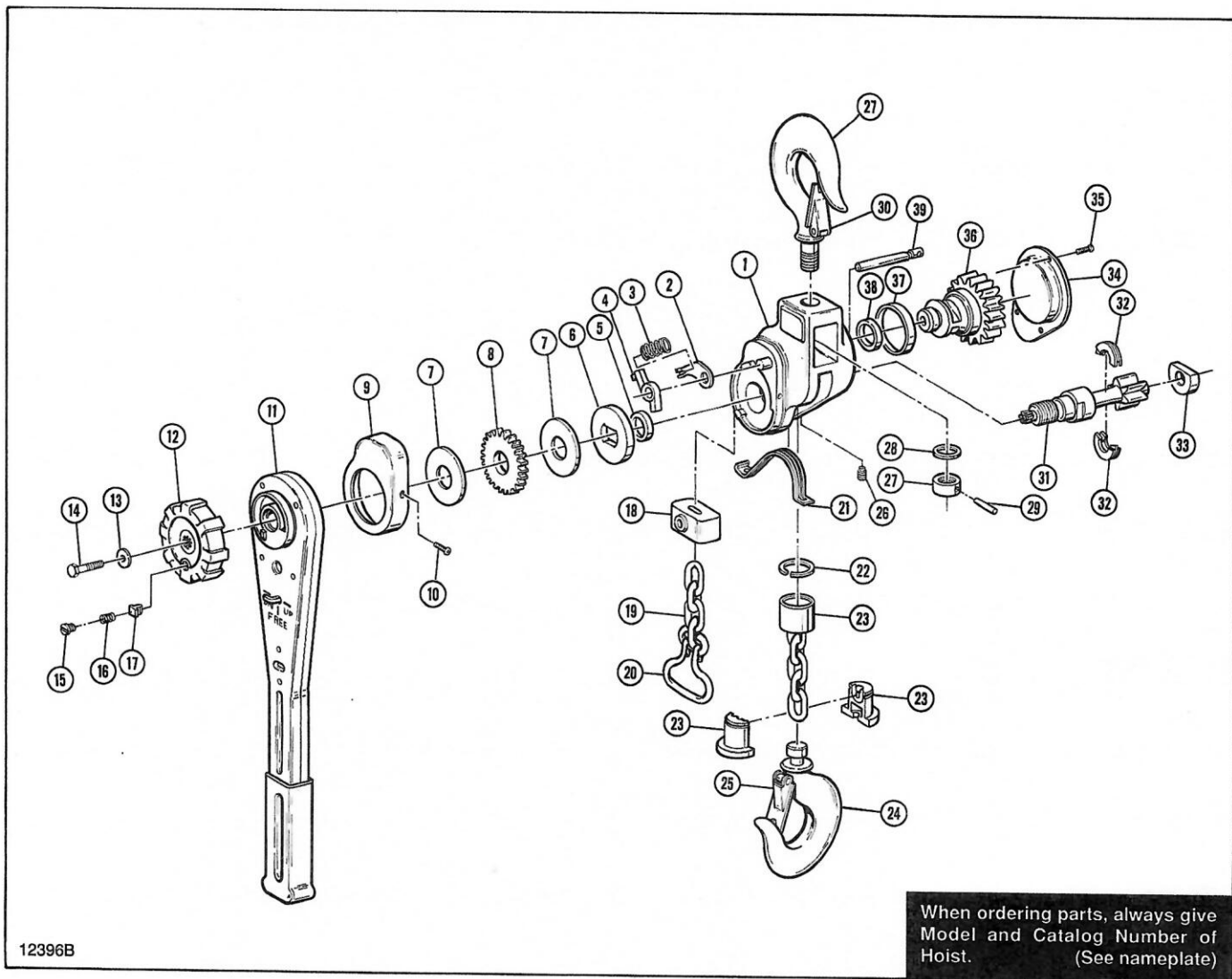

Figure 9-1. Frame and Gearing

Ref. No.	Part Number	Description	Qty. Req'd.
1		Frame Assembly (Includes Bronze Bearings, Ref. Nos. 5, 37 and 38, Plus Load Brake Pawl Pin, Not Shown)	
	T-400	For 1-1/2 and 4-1/2 Ton Models	1
	T-401	For 3 and 6 Ton Models	1
2	T-402	Retaining Plate - Load Brake Pawl Spring	1
3	T-403	Spring - Load Brake Pawl	1
4	T-404	Pawl - Load Brake	1
5	T-405	Bearing - Bronze - Pinion Shaft	1
6	T-406	Brake Flange	1
7	T-407	Friction Washer - Brake	2
8	T-408	Ratchet - Load Brake	1
9	T-409	Cover - Load Brake	1
10	T-410	Screw - Pan Head	3
11		Handle Assembly	
	T-411	Standard Models	1
	T-412	Redline Models	1
12	T-413	Hand Wheel	1
13	T-414	Washer - Flat	1
14	T-415	Bolt - Hex Head, Self-Locking	1
15	T-416	Plug - Hand Wheel	1
16	T-417	Spring - Hand Wheel	1

Figure 9-1. Frame and Gearing (Continued)

Ref. No.	Part Number	Description	Qty. Req'd.
17		Plunger - Hand Wheel	
	T-418	Standard Models	1
	T-418A	Redline Models	1
18	T-419	Chain Anchor - 3 and 6 Ton Models Only	1
19		Load Chain Assembly (Includes Welded End Link)	
	T-420	For 1-1/2 Ton Model With 4'-6" Lift	1
	T-457	For 1-1/2 Ton Model With 5'-0" Lift	1
	T-421	For 1-1/2 Ton Model With 7'-0" Lift	1
	T-422	For 1-1/2 Ton Model With 10'-0" Lift	1
	T-423	For 1-1/2 Ton Model With 12'-0" Lift	1
	T-424	For 1-1/2 Ton Model With Non-Standard Lift (Order Chain Length Equal to Lift Plus 5-3/4**)	1
	T-422	For 3 Ton Model With 4'-6" Lift	1
	T-458	For 3 Ton Model With 5'-0" Lift	1
	T-425	For 3 Ton Model With 7'-0" Lift	1
	T-426	For 3 Ton Model With 10'-0" Lift	1
	T-427	For 3 Ton Model With 12'-0" Lift	1
	T-424	For 3 Ton Model With Non-Standard Lift (Order Chain Length Equal to Two Times Lift, Plus 14-1/2**)	1
	T-425	For 4-1/2 Ton Model With 4'-6" Lift	1
	T-428	For 4-1/2 Ton Model With 7'-0" Lift	1
	T-429	For 4-1/2 Ton Model With 10'-0" Lift	1
	T-430	For 4-1/2 Ton Model With 12'-0" Lift	1
	T-424	For 4-1/2 Ton Model With Non-Standard Lift (Order Chain Length Equal to Three Times Lift, Plus 21**)	1
	T-431	For 6 Ton Model With 4'-6" Lift	1
	T-432	For 6 Ton Model With 7'-0" Lift	1
	T-433	For 6 Ton Model With 10'-0" Lift	1
	T-434	For 6 Ton Model With 12'-0" Lift	1
	T-424	For 6 Ton Model With Non-Standard Lift (Order Chain Length Equal to Four Times Lift, Plus 26**)	1
20	T-460	End Link	1
21	T-436	Chain Guide	1
	T-437	Lower Block Assembly For 1-1/2 Ton Model (Includes Ref. Nos. 22 thru 25)	1
22	T-438	Retaining Ring	1
23	T-439	Body and Sleeve Kit (Includes Lower Block Sleeve Plus Two Lower Block Body Halves Plus Retaining Ring, Ref. No. 22)	1
24	T-440	No. 5 Lower Hook	1
25	T-441	Hook Latch Assembly - Lower	1
		Lower Block Assembly For 3 Ton Model	See Fig. 9-2.
		Lower Block Assembly For 4-1/2 Ton Model	See Fig. 9-2.
		Lower Block Assembly For 6 Ton Model	See Fig. 9-2.
26	T-442	Set Screw - 3 and 6 Ton Models Only	1
27		Upper Hook and Nut Assembly	
	T-443	For 1-1/2 Ton Model (Includes No. 5 Hook and Nut)	1
	T-444	For 3 Ton Model (Includes No. 6 Hook and Nut)	1
28	T-445	Thrust Washer for 1-1/2 and 3 Ton Models	1
29	T-446	Grooved Pin for 1-1/2 Ton and 3 Ton Models	1
30		Hook Latch Assembly - Upper	
	T-441	For 1-1/2 Ton Model	1
	T-447	For 3 Ton Model	1
		Upper Block Assembly For 4-1/2 Ton Model	See Fig. 9-3.
		Upper Block Assembly For 6 Ton Model	See Fig. 9-3.
31	T-448	Pinion Shaft	1
32	T-449	Thrust Bearing - Pinion	2
33	T-450	Bearing - Pinion	1
34	T-451	Cover - Gear Case	1
35	T-452	Screw - Pan Head	3
36	T-453	Sprocket	1
37	T-454	Bronze Bearing - Sprocket	1
38	T-455	Bronze Bearing - Sprocket	1
39	T-456	Pin - Chain Anchor - 3 and 6 Ton Models Only	1

\*Round up to next full foot of length.

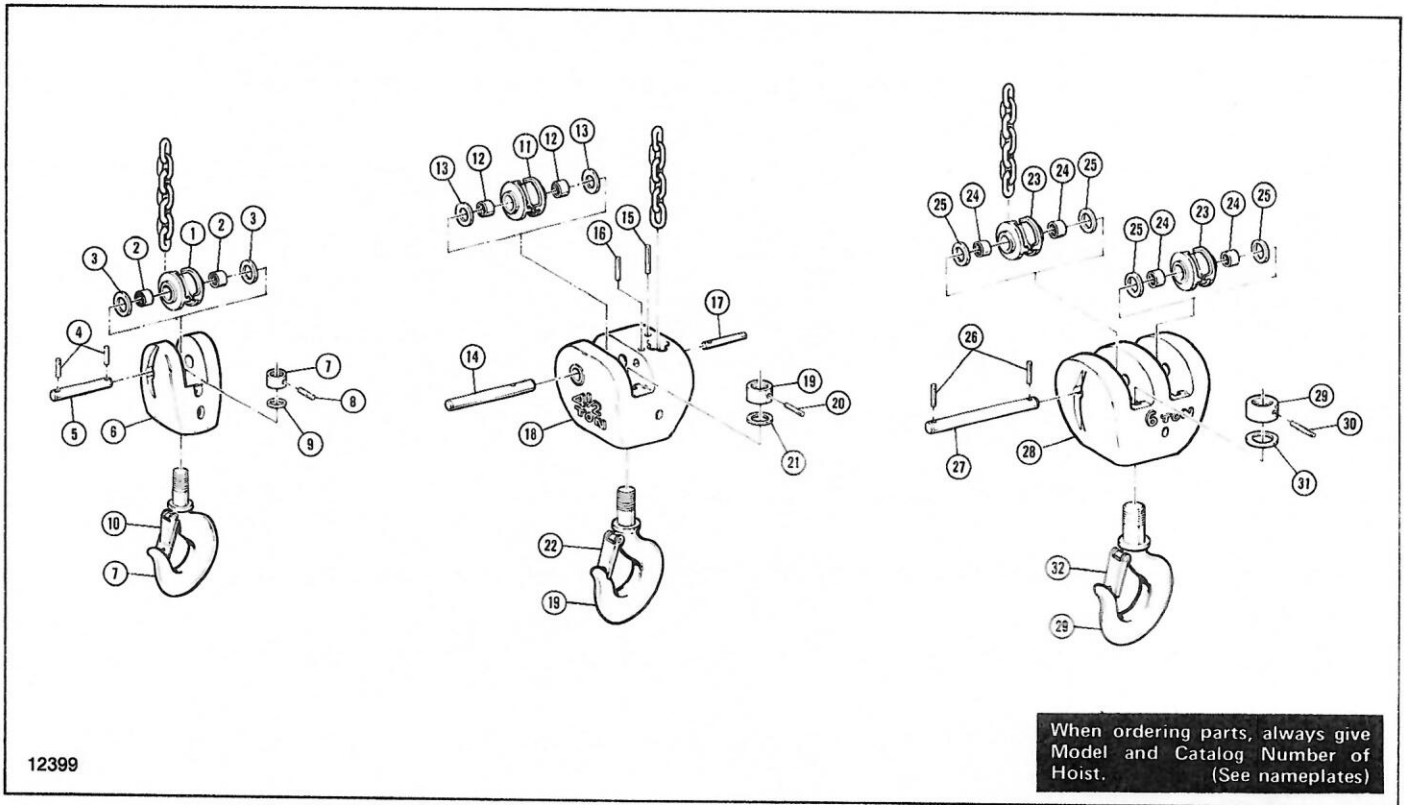
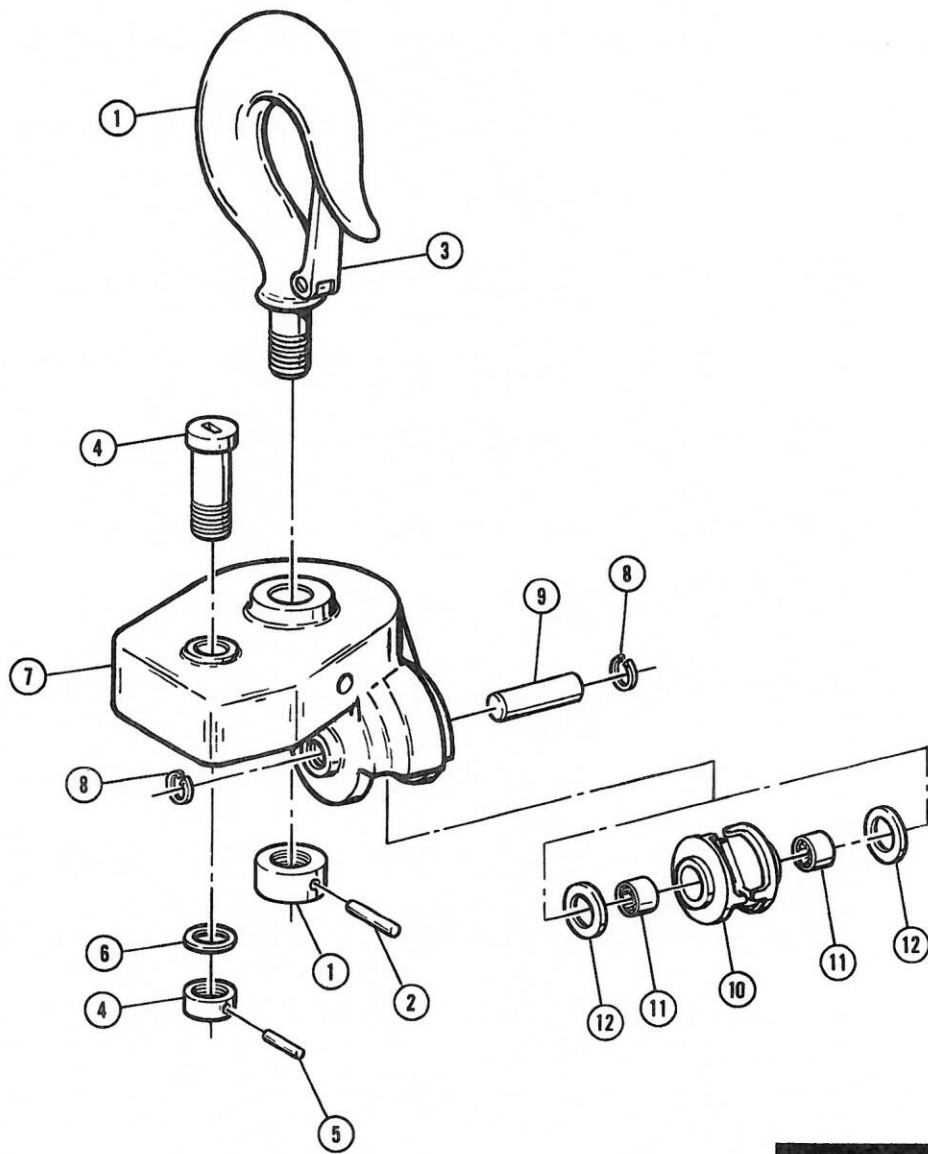

Figure 9-2. Lower Blocks For 3, 4-1/2 and 6 Ton Models

Ref. No.	Part Number	Description	Qty. Req'd.
	T-500	Lower Block Assembly For 3 Ton Model (Includes Ref. Nos. 1 thru 10)	1
1	T-501	Sprocket	1
2	T-502	Bearing - Needle	2
3	T-503	Washer	2
4	T-504	Pin - Spring	2
5	T-505	Shaft	1
6	T-506	Body - Lower Block	1
7	T-507	Hook and Nut Assembly (Includes No. 6 Hook and Nut)	1
8	T-508	Pin - Grooved	1
9	T-509	Thrust Washer	1
10	T-510	Hook Latch Assembly	1
	T-511	Lower Block Assembly For 4-1/2 Ton Model (Includes Ref. Nos. 11 thru 22)	1
11	T-501	Sprocket	1
12	T-502	Bearing - Needle	2
13	T-503	Washer	2
14	T-512	Shaft	1
15	T-513	Pin - Spring	1
16	T-514	Pin - Spring	1
17	T-515	Pin - Chain Anchor	1
18	T-516	Body - Lower Block	1
19	T-517	Hook and Nut Assembly (Includes No. 8 Hook and Nut)	1
20	T-518	Pin - Grooved	1
21	T-519	Thrust Washer	1
22	T-520	Hook Latch Assembly	1
	T-521	Lower Block Assembly For 6 Ton Model (Includes Ref. Nos. 23 thru 32)	1
23	T-501	Sprocket	2
24	T-502	Bearing - Needle	4
25	T-503	Washer	4
26	T-504	Pin - Spring	2
27	T-522	Shaft	1
28	T-523	Body - Lower Block	1
29	T-524	Hook and Nut Assembly (Includes No. 9 Hook and Nut)	1
30	T-525	Pin - Grooved	1
31	T-526	Thrust Washer	1
32	T-527	Hook Latch Assembly	1



When ordering parts, always give Model and Catalog Number of Hoist. (See nameplates)

12398

Figure 9-3. Upper Blocks for 4-1/2 and 6 Ton Models

Ref. No.	Part Number	Description	Qty. Req'd.
1	T-600 T-601	Hook And Nut Assembly For 4-1/2 Ton Model (Includes No. 8 Hook and Nut) For 6 Ton Model (Includes No. 9 Hook and Nut)	1 1
2	T-602	Pin - Grooved	1
3	T-603 T-604	Hook Latch Assembly For 4-1/2 Ton Model For 6 Ton Model	1 1
4	T-605	Hanger Bolt Assembly (Includes Hanger Bolt and Nut)	1
5	T-606	Pin - Grooved	1
6	T-607	Thrust Washer	1
7	T-608	Body - Upper Block	1
8	T-609	Ring - Retaining	1
9	T-610	Shaft	2
10	T-611	Sprocket	1
11	T-612	Bearing - Needle	2
12	T-613	Washer	2

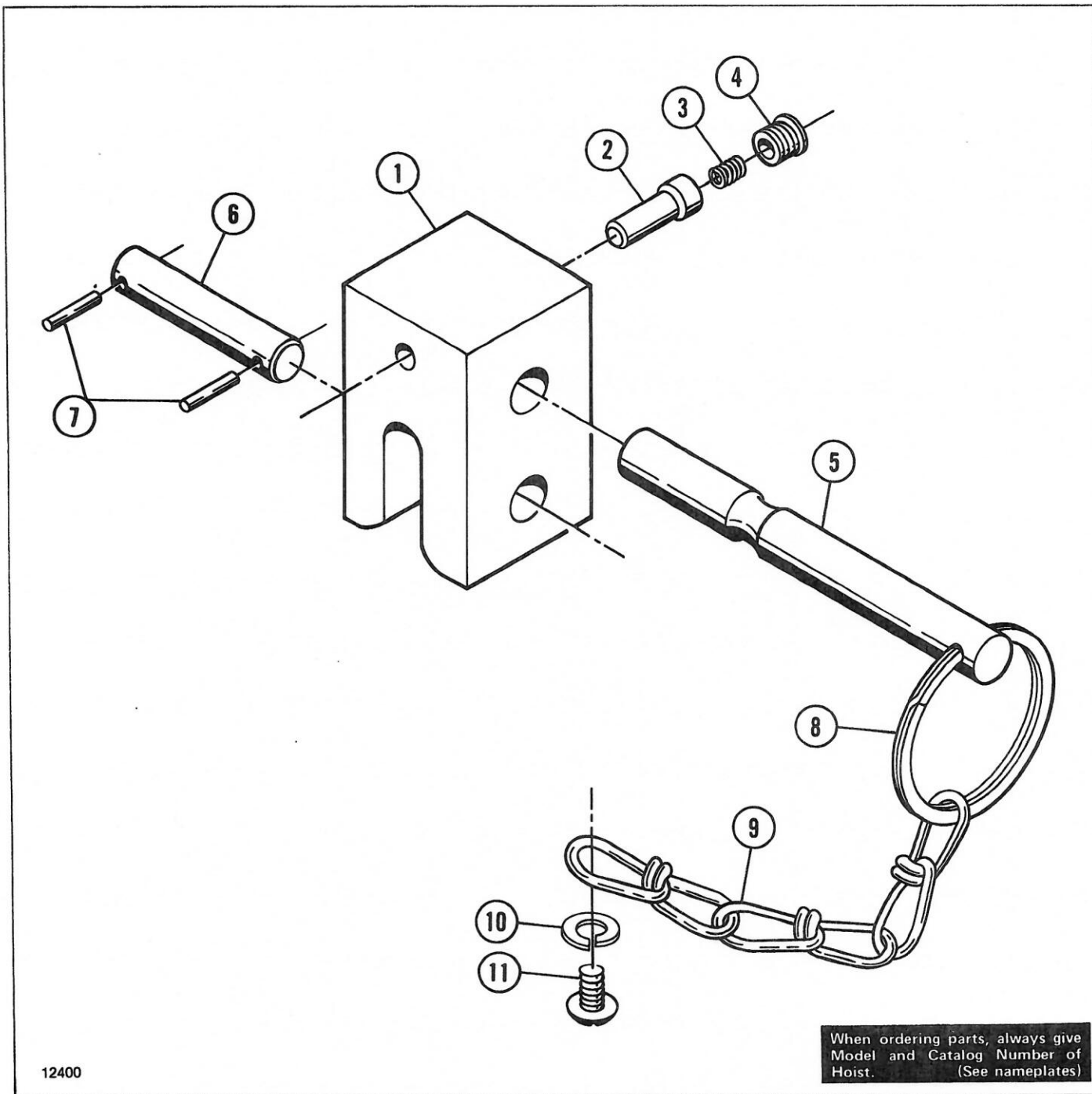

12400

Figure 9-4. Convertible Model Conversion Parts

Ref. No.	Part Number	Description	Qty. Req'd.
	T-700	Chain Anchor Assembly (Includes Ref. Nos. 1 thru 7)	1
1	T-701	Body - Chain Anchor	1
2	T-702	Plunger	1
3	T-703	Spring	1
4	T-704	Plug - Spring	1
5	T-712	Pin - Upper	1
6	T-706	Pin - Lower	1
7	T-707	Pin - Spring	2
8	T-708	Key Ring	1
9	T-709	Chain	1
10	T-710	Lockwasher	1
11	T-711	Screw - Round Head	1

## SECTION X — HOIST HANDLE SERVICE AND PARTS LIST

To disassemble handle, remove grip, cut or grind off heads of seven rivets and separate handle halves. Internal parts then lift out.

Before reassembly, clean and inspect all parts. Replace parts that are damaged or excessively worn.

Lubricate both faces of the load brake nut or the load regulator assembly where it contacts the handle halves with No. 3 lube paint (a graphite lube manufactured by Superior Graphite Co.), or equal. Apply a light film of N.L.G.I. EP-2 grease to the bearing surfaces of the

spring, thumb lever and pawl pivot pin and to the engagement surfaces of the pawl.

To assemble handle, insert thumb lever in one handle half with the lever turned to "FREE." Holding the lever in place, turn the handle half with the lever down and lay on work bench. Block handle level and set other internal parts in their proper positions. Be sure that load brake nut or load regulator assembly has the flat face up. Lay on other handle half and clamp together for riveting. Recommended method of riveting is spin riveting. Replace grip.

Ref. No.	Part Number	Description	Qty. Req'd.
1	T-800	Handle Half	2
2	T-801	Load Brake Nut - For Standard Models	1
	T-802	Load Regulator Assembly - For Redline Models	1
3	T-803	Pawl	1
4	T-804	Pin - Pawl Pivot	1
5	T-805	Thumb Lever	1
6	T-806	Spring - Handle	1
7	T-807	Rivet - Shoulder	7
8	T-808	Grip	1
	T-809	For Redline Models	1

Figure 10-1. Hoist Handle Parts







**SAFE IS... KNOWING YOUR HOIST!**  
 STUDY MANUFACTURER'S OPERATING INSTRUCTION MANUAL FOR CORRECT HOIST OPERATION. KNOW WHAT TO DO, -AND HOW TO DO IT! ... EVERYTIME!

**WOW! I DIDN'T KNOW THAT!**

HOIST OPERATING MANUAL

**SAFE IS... NEVER OVERLOADING!**  
 ALWAYS BE SURE TO USE PROPER CAPACITY HOIST. ... IN DOUBTFUL WEIGHT SITUATIONS USE HOISTS WITH OVERLOAD PROTECTION DEVICES WHICH WILL REJECT DANGEROUS OVERLOADS.

OW!

**SAFE IS... MAKING SURE UPPER SUSPENSION WILL HOLD THE LOAD!**

CRACK!

**SAFE IS... RIGGING THE HOIST CORRECTLY!**

	<b>ALWAYS KEEP LOAD CHAIN STRAIGHT!</b>		<b>DON'T USE LOAD CHAIN AS A LOAD SLING!</b>
<b>SNAP HOOK LATCH OVER LOAD SLING!</b>	<b>DON'T BEND LOAD CHAIN OVER SHARP EDGES!</b>	<b>DON'T LET LOAD CHAIN PULL AGAINST HOIST!</b>	<b>DON'T BEND LOAD CHAIN OVER SHARP EDGES!</b>
<b>ALWAYS BALANCE LOAD IN SLING!</b>			

**SAFE IS... NEVER USING A HOIST WITH "OPENED" HOOKS!**

CHECK HOOKS OFTEN WITH SCALE OR GAUGE!

**SAFE IS... NEVER USING A HOIST WITH SLIPPING BRAKE!**

CHECK LOAD BRAKE OPERATION OFTEN!

**SAFE IS... NEVER USING A DAMAGED HOIST!**

VISUALLY CHECK HOIST CONDITION!

**SAFE IS... USING GOOD JUDGMENT!**

NEVER THROW OR DROP A HOIST!

**SAFE IS... NEVER TWISTING CHAIN BY CAPSIZING LOWER BLOCK!**

**SAFE IS... ALWAYS MAKING SURE OF YOUR FOOTING!**

ALWAYS LOOK WHERE YOU'RE GOING!

**SAFE IS... ALWAYS STAYING OUT FROM UNDER A SUSPENDED LOAD!**

NEVER CARRY PEOPLE ON A HOIST OR THE LOAD. NEVER CARRY LOADS OVER PEOPLE!

**SAFE IS... NEVER USING A PIPE (CHEATER) ON LEVER HOIST HANDLE!**

... SOMETHING'S BOUND TO "GIVE"!

**SAFE IS... NEVER PERMITTING A WELDING TORCH TO HEAT LOAD CHAIN!**

**SAFE IS... NEVER APPLYING SHOCK LOAD TO CHAIN SUDDENLY!**

**SAFE IS... ALSO**

- NEVER DRAGGING A LOAD CHAIN FROM UNDER THE LOAD!
- BEING A THOUGHTFUL, COURTEOUS WORKER!

**Safe is Beautiful**

## Recommended Spare Parts for Your TUGIT Hoist

Certain parts of your hoist will, in time, require replacement under normal wear conditions. It is suggested that the following parts be purchased for your hoist as spares for future use.

Description	Quantity for One Hoist	Quantity for Five Hoists	Quantity for Ten Hoists
Hoist Pawl	—	1	2
Friction Washer	2	4	6
Load Chain	—	1	2
Lower Hook	—	1	2
Handle Assembly	—	—	1
Upper Hook Assembly	—	—	1

NOTE: When ordering parts always furnish Model and Catalog Number of Hoist and lift of hoist on which the parts are to be used.

Parts for your hoist are available from your local authorized BUDGIT/TUGIT repair station. For the location of your nearest repair station, write:

**In USA**

LIFT-TECH INTERNATIONAL  
P.O. BOX 769  
MUSKEGON, MI 49443-0769

**In CANADA**

LIFT-TECH INTERNATIONAL  
CRANES & HOISTS  
53-D COWANSVIEW ROAD  
CAMBRIDGE, ONTARIO, N1R 7L2

or phone: 616-733-0821  
or fax: 800-742-9270

519-621-3201  
519-621-3125

# WARRANTY

### WARRANTY AND LIMITATION OF REMEDY AND LIABILITY

A. Seller warrants that its products and parts, when shipped, and its work (including installation, construction and start-up), when performed, will meet applicable specifications, will be of good quality and will be free from defects in material and workmanship. All claims for defective products or parts under this warranty must be made in writing immediately upon discovery and, in any event, within one (1) year from shipment of the applicable item unless Seller specifically assumes installation, construction or start-up responsibility. All claims for defective products or parts when Seller specifically assumes installation, construction or start-up responsibility, and all claims for defective work must be made in writing immediately upon discovery and, in any event, within one (1) year from completion of the applicable work by Seller, provided; however, all claims for defective products and parts must be made in writing no later than eighteen (18) months after shipment. Defective items must be held for Seller's inspection and returned to the original f.o.b. point upon request. **THE FOREGOING IS EXPRESSLY IN LIEU OF ALL OTHER WARRANTIES WHATSOEVER, EXPRESS, IMPLIED AND STATUTORY, INCLUDING, WITHOUT LIMITATION, THE IMPLIED WARRANTIES OF MERCHANTABILITY AND FITNESS.**

B. Upon Buyer's submission of a claim as provided above and its substantiation, Seller shall at its option either (i) repair or replace its product, part or work at either the original f.o.b. point of delivery or at Seller's authorized service station nearest Buyer or (ii) refund an equitable portion of the purchase price.

C. This warranty is contingent upon Buyer's proper maintenance and care of Seller's products, and does not extend to fair wear and tear. Seller reserves the right to void warranty in event of Buyer's use of inappropriate materials in the course of repair or maintenance, or if Seller's products have been dismantled prior to submission to Seller for warranty inspection.

D. The foregoing is Seller's only obligation and Buyer's exclusive remedy for breach of warranty, and is Buyer's exclusive remedy hereunder by way of breach of contract, tort, strict liability or otherwise. In no event shall Buyer be entitled to or Seller liable for incidental or consequential damages. Any action for breach of this agreement must be commenced within one (1) year after the cause of action has accrued.

**LIFTTECH** 

LIFT-TECH INTERNATIONAL  
CRANE AND HOIST OPERATIONS  
MUSKEGON, MICHIGAN 49443-0769