

# Clamps, Grabs & Tongs

## Model BLG - Barrier Grabs

**NEW**



**INSTOCK PROGRAM**

### PRODUCT FEATURES:

- New, compact & rugged design holds up to the work environment where barriers are used.
- Handles concrete barriers from 6" - 12" nominal width at the top of the barrier.
- Stainless steel Auto-Latch.
- Auto-Latch mounting insures proper alignment.
- Locating assembly orientates tong on barrier without operator intervention.
- Gripping pads pivot to conform with the load.
- Replaceable polyurethane pads protect barrier.
- Alloy steel dog-point pads bite into painted barrier surfaces (typical in coastal areas).
- Centering guide cut out on grab shoe helps to properly center tong over barrier for a level lift.
- Extended handles on each side keep operator away from load and can be adjusted as needed.
- Lifting eye allows for easy hook attachment, self-centers rigging, and will accommodate a fork.
- Designed and manufactured to ASME B30.20, BTH-1, design category B, service class 3.

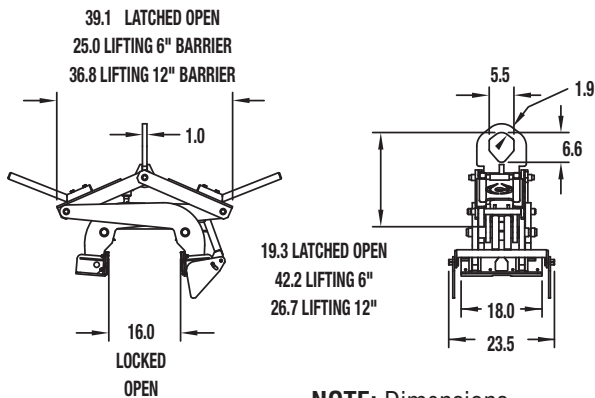

**NOTE:** Dimensions shown in inches.

### SPECIFICATIONS

Model Number	Rated Capacity (lbs.)	Weight (lbs.)
<b>With Polyurethane Lifting Pads</b>		
BLG-4.1/4	8500	602
BLG-7.1/4	14500	652
<b>With Steel 'Dog Point' Lifting Pads</b>		
BLG-4.1/4-DP	8500	602
BLG-7.1/4-DP	14500	652

## Operation

Place tong on barrier, lower crane completely to disengage the Auto-Latch.

Lift and position barrier in desired location.

Lower crane, line must go slack to engage Auto-Latch, lift tong off barrier and Repeat!



# Clamps, Grabs & Tongs

## Model BLG - Barrier Grab Options

### Optional Barrier Grab Rest Pad

**NEW**



#### OPTION FEATURES:

- Bolt in place for easy field installation and replacement
- Protects barrier from damaged caused by the grab, increasing barrier life.

### Optional Stabilizing Kit

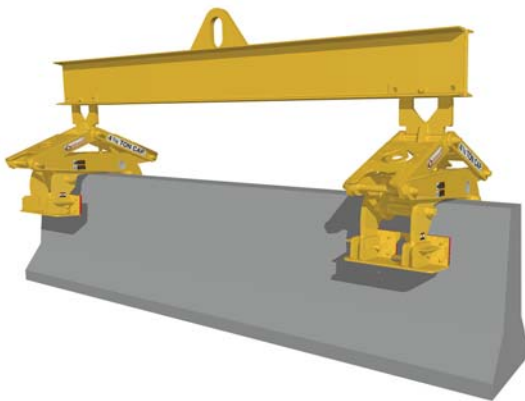

#### OPTION FEATURES:

- Attach two Barrier Grabs, and expand your barrier handling capabilities.
- Handles barriers up to 40' in length.
- Beams can be used for other material handling applications when Barrier Grabs are removed.

#### Each Stabilizing Kit Consists of:\*

- 1 - Model 20 Lifting Beam
- 1 - Set of attaching hardware

\*Barrier Grabs Sold Separately

### BLG-4.1/4-E Kit Entire Unit Rated Capacity: 17,000 lbs.

Designed for barriers  
12' or longer.

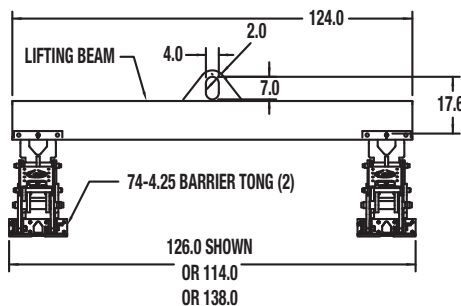

### BLG-7.1/4-E Kit Entire Unit Rated Capacity: 29,000 lbs.

Designed for barriers  
18' or longer.

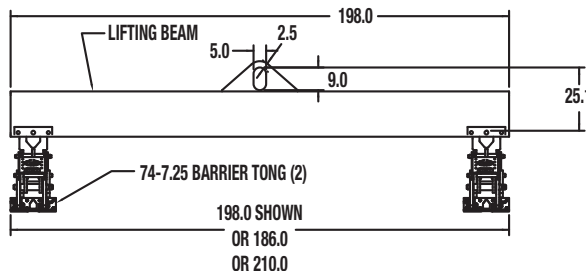

SEE BARRIER TONG CATALOG PAGE FOR MORE DIMENSIONS

NOTE: Dimensions shown in inches.