

# ED Electric Chain Hoists with Hook Suspension and Mini Trolley



ED250DS

In our ED Series of electric chain hoists, we offer the user a powerful combination of benefits. A wide variety of lifting speeds. A low headroom designed to fit most applications. A unique, ergonomically designed, one-handed cylinder control that results in maximum load control. These features tied together with the convenience of single-phase power, make these hoists ideal for both commercial and industrial applications.

## Features and Benefits

### ALL MODELS

#### Double Braking System

Provides protection with a Weston-style mechanical load brake and a regenerative brake.

#### Compact Design

Die-cast aluminum body is lightweight and low headroom to fit into tight areas. Easy to install, move and store.

#### Heavy Duty Motor

With .4 to .8 horsepower is above standard for industrial situations. The compact DC motor with rectifier for AC current reduces weight, generates less heat and maintains duty cycles.

#### High Performance Friction Clutch

Is integrated with the load brake and designed to slip to prevent overwinding or overtravel.

#### Heat Treated Gearing

Deep-groove ball and needle bearings are immersed in an oil bath resulting in smooth, quiet operation.

### UNIQUE TO DUAL SPEED (DS) MODEL

#### Speed Flexibility

Low speed adjustable from 0 to 100% of maximum speed by setting screw inside the pendant.

### UNIQUE TO CYLINDER CONTROL (DA) MODEL

#### In-Line Handgrip

Permits one-handed operation and gives the operator a free hand to easily position the load.

#### Removable Bottom Hook

Permits insertion of a variety of below-the-hook material handling devices.

#### High/Low Speeds

Easy touch rocker switch above handgrip allows quick selection between low and high speed control. Finger turn knobs allow custom setting of speeds from 0-100%.

### UNIQUE TO DUAL SPEED INFINITY (DSA) MODEL

#### Speed Adjustment

Pendant has external speed adjustment knobs to customize the high and low speeds.

#### Heavy Duty Metal Hinged Cover

Protects pendant knobs from damage and prevents speed settings from shifting during operation.

### UNIQUE TO VARIABLE SINGLE SPEED (V) MODEL

#### Smart Speed Technology

Ability to increase factory set speed to a higher speed with a simple adjustment inside the hoist.

## Standard Hoist Specifications

### Capacity Range

125 lb.-1050 lb.

### Voltage

120-1-60

### Control Voltage

120V Direct

### Duty Cycle\*

Varies by capacity — see charts

### Ratings

Hoist — IP54

Pendant — IP65

Cylinder Control — IP44

### Limit Switch

Prevents overwinding/overlifting  
Standard upper

### Chain Falls

Single fall — 125-525 lb.

Double fall — 1000-1050 lb.

### Standard Lengths

Single/Dual Speeds Lift — 10'

Cylinder Control Lift — 6'

Single/Dual Speeds Pendant

Drop — 3' less than lift

Cylinder Control — 9' reach (approx.)

(reach equals lift plus headroom)

Power Supply — 16'

(longer lengths available)

### Standard Pendants

Single/Dual Speeds — 2 button  
Momentary contacts

### Chain Containers

Standard

Plastic

### Mini Trolley

Fits all ED models up to 525 lb. capacity

For 1000 and 1050 lb. capacities or wider flanges use PT005 trolley

\*See page 59 for additional information.

## HARRINGTON ELECTRIC CHAIN HOISTS



ED525DA

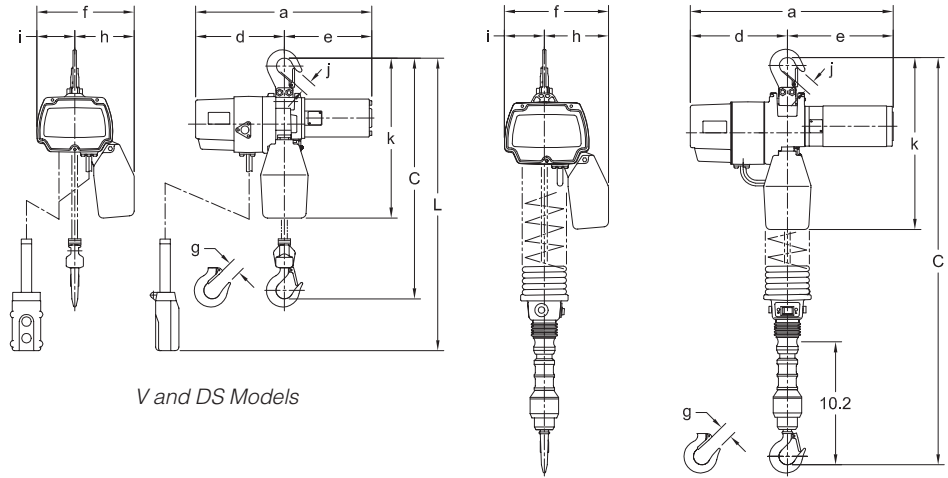

V and DS Models

DA Model  
(Dimensions in inches.)

### HOIST—SPECIFICATIONS

Cap. (lbs)	Product Code			Lifting Speed (ft/min)			Standard Lift (ft)		Push Button Cord L (ft)		Motor Output (Hp)	Intermittent Duty Rating		Short Time Duty Rating (min)	Lifting Motor 1 Phase 60 Hz Rated Current at 120V (amps)
	Variable Single Speed (V) Model	Dual Speed (DS) Model	Dual Adjustable (DA) Model	V Model*		DS & DA Model	V & DS Model	DA Model	V & DS Model	DA Model		Duty Rating % ED	Max. Start Freq. (times/hr)		
				Std.	Max. Adj.										
125	-	ED125DS	ED125DA	-	-	69/13	10	6	8	Coiled	0.4	30	180	15	5
220	-	ED220DS	ED220DA	-	-	43/10	10	6	8	Coiled	0.4	30	180	15	5
250	-	ED250DS	ED250DA	-	-	26/10	10	6	8	Coiled	0.4	20	120	10	6
250	ED250V	-	-	16	26	-	10	-	8	-	0.4	20	120	10	6
350	-	ED350DS	ED350DA	-	-	66/13	10	6	8	Coiled	0.8	30	180	20	10
350	ED350V	-	-	16	44	66/13	10	-	8	-	0.8	30	180	20	10
400	-	ED400DS	ED400DA	-	-	26/10	10	6	8	Coiled	0.4	20	120	10	6
500	ED500V	-	-	16	44	-	10	-	8	-	0.8	30	180	15	10
525	-	ED525DS	ED525DA	-	-	44/10	10	6	8	Coiled	0.8	30	180	20	10
1000	ED1000V	-	-	8	22	-	10	-	8	-	0.8	30	180	20	10
1050	-	ED1050DS	-	-	-	22/6	10	-	8	-	0.8	30	180	20	10

\*The V Model is Factory set at the "Std" speed. It can be adjusted up to the "Max. Adj." speed.

### HOIST—DIMENSIONS AND WEIGHTS

Cap. (lbs)	Headroom C (in)		a (in)	d (in)	e (in)	f (in)	g (in)	h (in)	i (in)	j (in)	k (in)	Net Weight (lbs)			Weight for Additional One Foot of Lift (lbs)	
	V & DS Model	DA Model										V Model	DS Model	DA Model	V Model	DS Model
125	12.4	37.2	14.6	7.4	7.2	8.1	1	4.9	3.1	1	13.4	23	24	31	0.26	0.29
220	12.4	37.2	14.6	7.4	7.2	8.1	1	4.9	3.1	1	13.4	23	24	31	0.26	0.29
250	12.4	37.2	14.6	7.4	7.2	8.1	1	4.9	3.1	1	13.4	24	25	32	0.26	0.29
250	12.4	-	14.6	7.4	7.2	8.1	1	4.9	3.1	1	13.4	24	-	-	0.26	-
350	13	37.8	16.9	8.1	8.8	8.6	1	5.3	3.3	1	14.3	33	34	40	0.26	0.29
350	13	-	16.9	8.1	8.8	8.6	1	5.3	3.3	1	14.3	33	-	-	0.26	-
400	12.4	37.2	14.6	7.4	7.2	8.1	1	4.9	3.1	1	13.4	24	25	32	0.26	0.29
500	13	-	16.9	8.1	8.8	8.6	1	5.3	3.3	1	14.3	33	-	-	0.26	-
525	13	37.8	16.9	8.1	8.8	8.6	1	5.3	3.3	1	14.3	33	34	40	0.26	0.29
1000	20.5	-	16.9	8.1	8.8	9	0.9	6.1	2.9	1	17.9	46	-	-	0.49	-
1050	20.5	-	16.9	8.1	8.8	9	0.9	6.1	2.9	1	17.9	46	47	-	0.49	0.52

# ED Electric Chain Hoists with Hook Suspension and Mini Trolley



ED525DSA

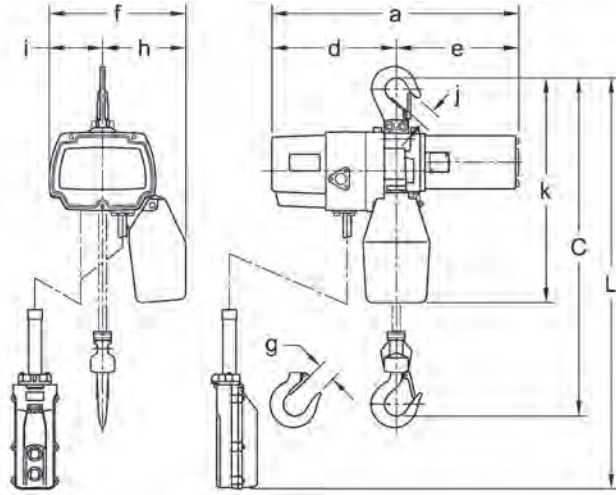

ED525DSA

## HOIST—DIMENSIONS AND WEIGHTS

Cap. (lbs)	Product Code	Lifting Speed (ft/min)	Standard Lift (ft)	Push Button Cord L (ft)	Motor Output (HP)	Intermittent Duty Rating		Short Time Duty Rating (min)	Rated Current at 120V (amps)
						Duty Rating % ED	Max. Start Freq. (Times/Hr)		
125	ED125DSA	69/13	10	8	0.4	30	180	15	5
220	ED220DSA	43/10			0.4	30	180	15	5
250	ED250DSA	26/10			0.4	20	120	10	6
350	ED350DSA	66/13			0.8	30	180	20	10
400	ED400DSA	26/10			0.4	20	120	10	6
525	ED525DSA	44/10			0.8	30	180	20	10
1050	ED1050DSA	22/6			0.8	30	180	20	10

## HOIST—DIMENSIONS AND WEIGHTS

Cap. (lbs)	Headroom C (in)	a (in)	d (in)	e (in)	f (in)	g (in)	h (in)	i (in)	j (in)	k (in)	Net Weight (lbs)	Weight for Additional One Foot of Lift (lbs)
125	12.4	14.6	7.4	7.2	8.1	1.0	4.9	3.1	1.0	13.4	24	0.29
220	12.4	14.6	7.4	7.2	8.1		4.9	3.1		13.4	24	
250	12.4	14.6	7.4	7.2	8.1		4.9	3.1		13.4	25	
350	13.0	16.9	8.1	8.8	8.6		5.3	3.3		14.3	34	
400	12.4	14.6	7.4	7.2	8.1		4.9	3.1		13.4	25	
525	13.0	16.9	8.1	8.8	8.6		5.3	3.3		14.3	34	
1050	20.5	16.9	8.1	8.8	9.0		0.9	6.1		2.9	17.9	47

# ED Electric Chain Hoists

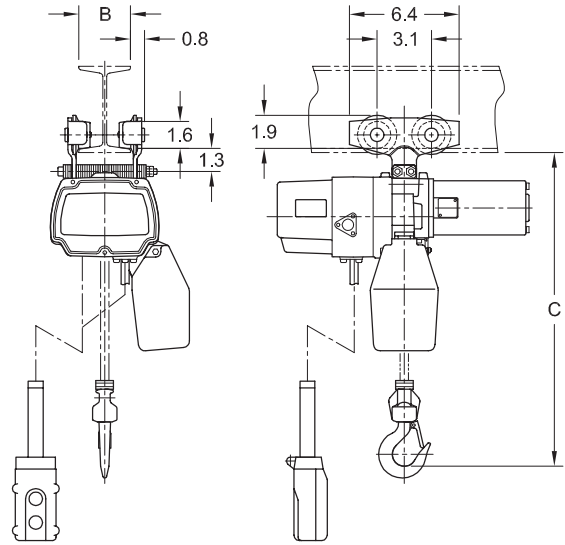
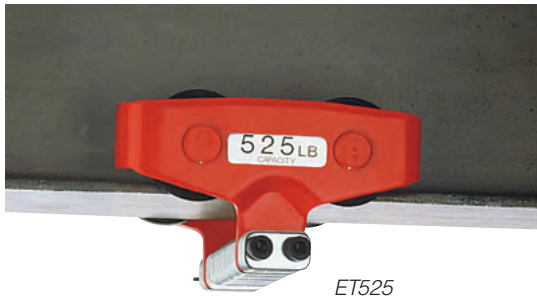

ET525 (Dimensions in inches.)

## ET MINI TROLLEY—SPECIFICATIONS

Maximum Capacity (lbs)	Product Code	Adjustable Beam Width B (in)	Minimum Radius For Curve (in)	Net Weight (lbs)	Approximate Shipping Weight (lbs)
525	ET525	1.97-3.94	23.6	4.0	5.0

## ET MINI TROLLEY—DIMENSIONS

Cap. (lbs)	Headroom C (in)	
	S & DS Models	DA Model
125	10.5	35.3
220		
250		
350	11.1	35.9
400	10.5	35.3
525	11.1	35.9