

## Wallace Tripod Cranes

Wallace Cranes offers 23 models of portable tripods. You may choose from adjustable height aluminum units, adjustable height steel units, fixed height aluminum units, or fixed height steel units. All units include a standard base with lashing cable. Rubber base pad kits, mud base plate kits, and spike base kits are optional for all units.

Tripod cranes are often recommended to help set-up our larger cranes when a forklift or overhead lifting equipment is not available. These lightweight cranes are easily transportable.

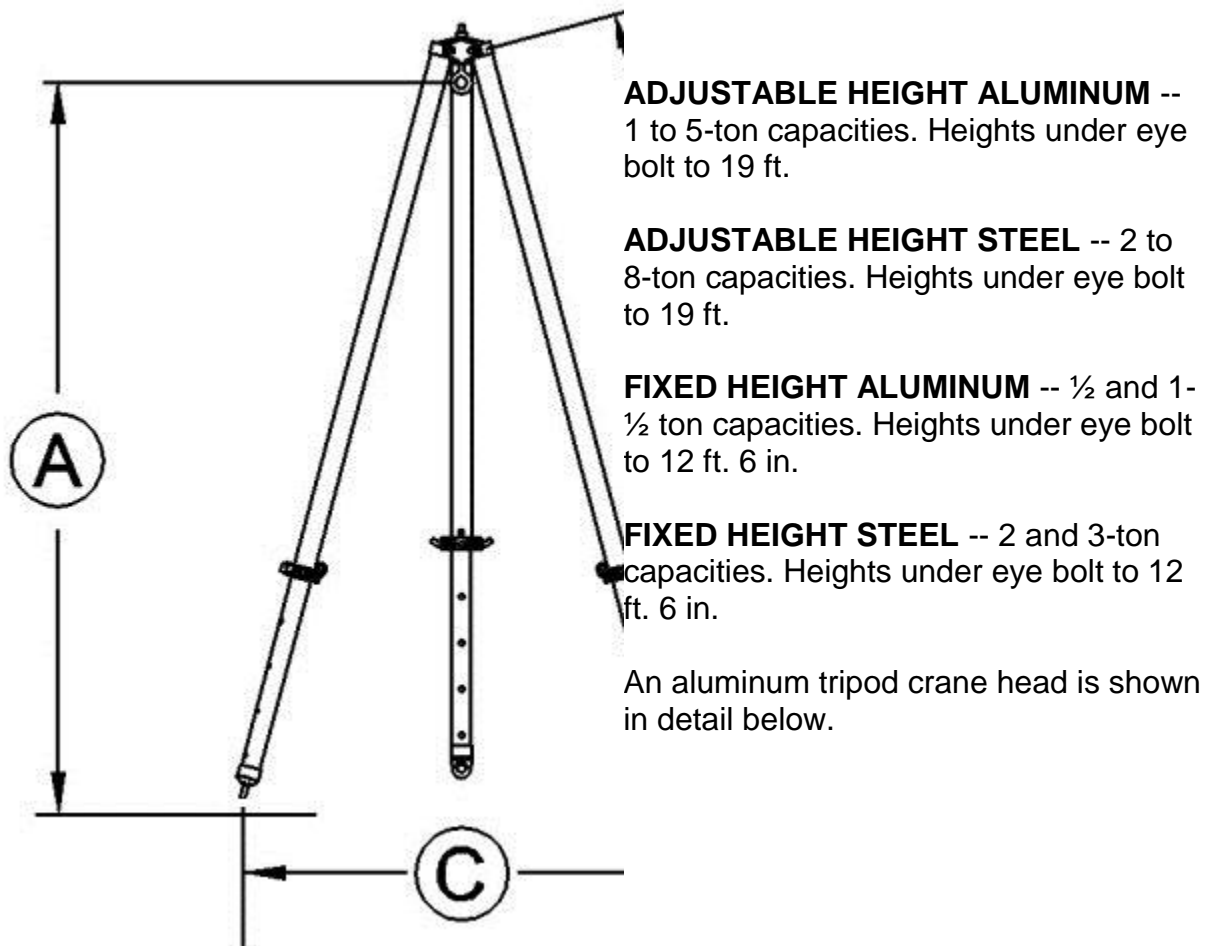

Heights under eyebolt are figured for optimum strength, (C) not exceeding 75% of adjusted (B).

NOTE: Tripods are not intended for lifting humans.



**Wallace Tripod Crane crane sizes model numbers**

## Wallace Tripods

	A		B		C				
Maximum Capacity	Height - Eye Bolt to Floor		Overall Length		Distance Between Legs		Net Wt.	Model Number	Spike Base Model Number
	Max.	Min.	Max.	Min.	Max.	Min.			
<b>Aluminum Adjustable Height Tripods</b>									
<b>1 TON</b>	10' 10"	7' 1"	12' 9"	8' 9"	111"	63"	79	R3-282	676
	19' 0"	12' 9"	21' 9"	14' 9"	192"	108"	216	H3-2142	1514
<b>2 TON</b>	16' 4"	11' 0"	18' 9"	12' 9"	165"	93"	174	H3-4122	1514
<b>3 TON</b>	5' 6"	3' 8"	6' 9"	4' 9"	57"	33"	57	R3-642	676
	8' 2"	5' 6"	9' 9"	6' 9"	84"	48"	70	R3-662	676
<b>4 TON</b>	12' 11"	8' 5"	15' 9"	10' 9"	138"	78"	156	H3-8102	1514
<b>5 TON</b>	7' 6"	4' 11"	9' 9"	6' 9"	84"	48"	111	H3-1062	1514
	10' 3"	6' 8"	12' 9"	8' 9"	111"	63"	124	H3-1082	1514
<b>Steel Adjustable Height Tripods</b>									
<b>2 TON</b>	16' 3"	10' 10"	18' 9"	12' 9"	165"	93"	225	R3-4121	676
<b>3 TON</b>	13' 7"	9' 1"	15' 9"	10' 9"	138"	78"	189	R3-6101	676
<b>5 TON</b>	10' 10"	7' 1"	12' 9"	8' 9"	111"	63"	160	R3-1081	676
<b>6 TON</b>	8' 2"	5' 6"	9' 9"	6' 9"	84"	48"	136	R3-1261	676
	18' 3"	12' 0"	21' 9"	14' 9"	192"	108"	411	H3-12141	1514
<b>7 TON</b>	10' 3"	6' 8"	12' 9"	8' 9"	111"	63"	253	H3-1481	1514
	15' 7"	10' 3"	18' 9"	12' 9"	165"	93"	453	H3-14121	1514
<b>8 TON</b>	7' 6"	4' 11"	9' 9"	6' 9"	84"	48"	210	H3-1661	1514
	12' 11"	8' 5"	15' 9"	10' 9"	138"	78"	385	H3-16101	1514
<b>Aluminum Fixed Height Tripods</b>									
<b>1/2 TON</b>	12' 6"	12' 6"	14' 9"		128"		61	4-10142	677
<b>1-1/2 TON</b>	5' 4"	5' 4"	6' 9"		56"		39	4-3062	677
	8' 11"	8' 11"	10' 9"		92"		50	4-30102	677
<b>Steel Fixed Height Tripods</b>									
<b>2 TON</b>	12' 6"	12' 6"	14' 9"		128"		144	4-40141	677
<b>3 TON</b>	5' 4"	5' 4"	6' 9"		56"		70	4-6061	677
	8' 11"	8' 11"	10' 9"		92"		106	4-60101	677
<p>Note: Maximum capacity is in thousands of pounds. Capacities derated at no additional charge. Simply change number in red to required capacity accordingly when ordering.</p>									
<b>OPTIONAL ACCESSORIES</b>									
<p><b>1) Kit #675 Rubber Base Pad:</b> Includes (3) 5"x3" aluminum bases with rubber pads to protect floor surface. Provides ideal stability on all hard floor surfaces.</p> <p><b>2) Kits #676, 677, #1514 Spike Base:</b> Includes (3) spikes and is designed for use in hard earth surfaces; can be used with mud base plate kit.</p> <p><b>1) Kit #1097 Mud Base Plate:</b> Includes (3) 12" square steel plates and provides additional leg support on all surfaces. May be used with either Rubber or Spike base kit.</p> <p><b>Call 1-800-553-LIFT for pricing.</b></p>									



**(L to R) Options: Mud Base Plate, Rubber Base, Spike Point. Note lashing for all configurations.**