

# WORK AREA PORTABLE GANTRY CRANE - FPG-3

APPROX WEIGHT: 226.25 lbs.  
 DOES NOT INCLUDE WEIGHT OF POWER OR PACKAGING!!!  
 DIMENSION TOLERANCE ± 1/4"

\*\*\* ANY ADDITIONS, DELETIONS, OR OMISSIONS MUST BE CORRECTED ON THIS DRAWING AS THIS DRAWING WILL BE CONSIDERED ALL INCLUSIVE \*\*\*

ALL GRAPHICS PROVIDED ARE FOR REFERENCE ONLY. IF CERTAIN DIMENSIONS ARE CRITICAL PLEASE VERIFY THOSE DIMENSIONS WITH YOUR SALESPERSON

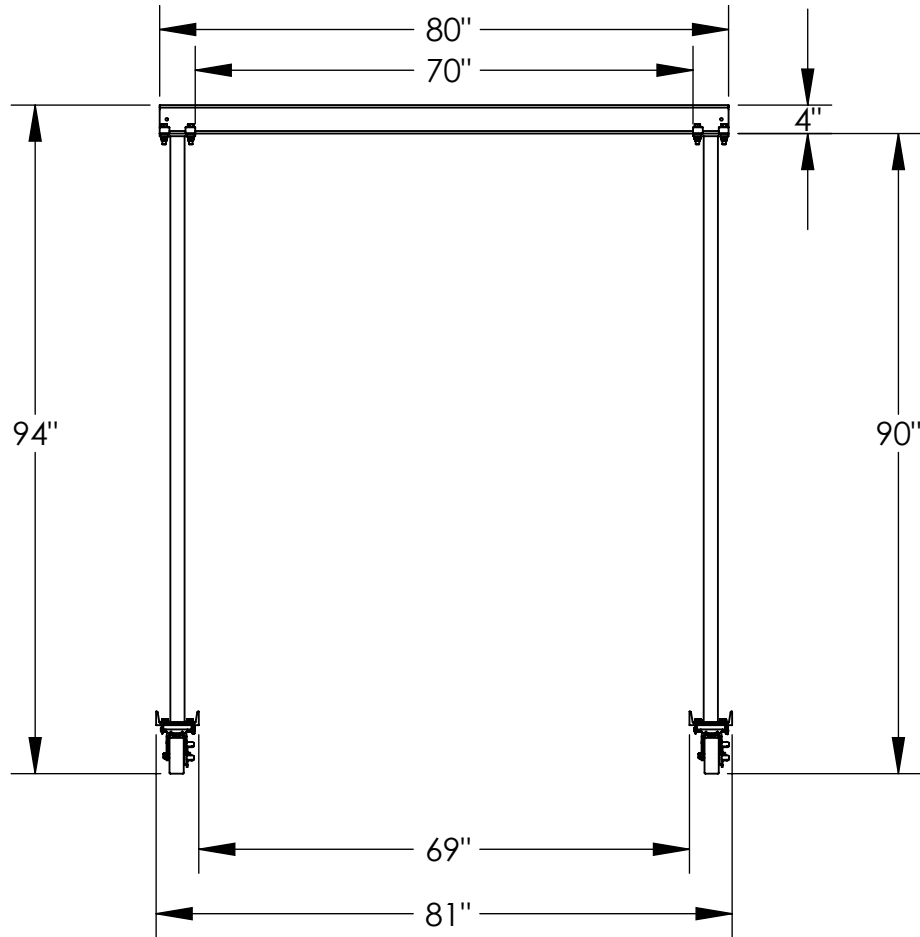

FOUR Ø5" x 2"  
 POLYURETHANE  
 SWIVEL CASTERS  
 W/ BRAKE

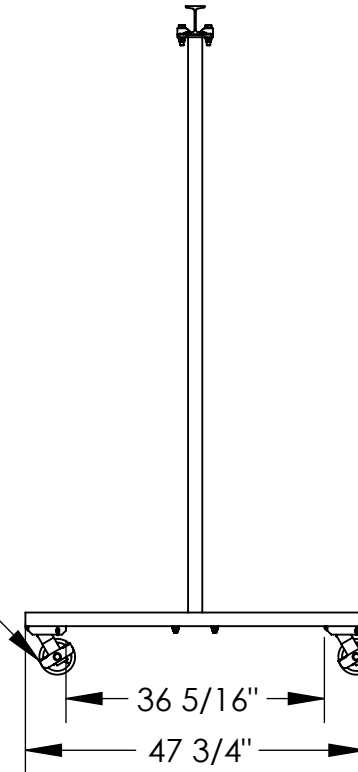

## STANDARD FEATURES

MODEL NUMBER IS FPG-3  
 CAPACITY IS 300 LBS.  
 OVERALL I-BEAM LENGTH IS 80"  
 USABLE I-BEAM LENGTH IS 70"  
 OVERALL WIDTH IS 47 3/4"  
 USABLE WIDTH IS 36 5/16"  
 OVERALL LENGTH IS 81"  
 STRADDLE LENGTH IS 69"  
 OVERALL HEIGHT IS 94"  
 UNDER I-BEAM HEIGHT IS 90"  
 I-BEAM HEIGHT IS 4"  
 BLUE POWDER COAT PAINT FINISH

## SPECIAL FEATURES

NONE

APPROVAL

I, THE UNDERSIGNED, AGREE THAT THE PRODUCT AS REPRESENTED SATISFIES DESIGN AND DIMENSION REQUIREMENTS. I ALSO ACKNOWLEDGE MY DUTY TO CONFIRM PRODUCT AND INSTALLATION COMPLIANCE WITH ALL APPLICABLE FEDERAL, STATE AND LOCAL REGULATIONS AND STANDARDS.  
**ALL SPECIAL UNITS ARE NON-RETURNABLE**  
 As drawn       As marked

Signed: \_\_\_\_\_ Date: \_\_\_\_\_

LEAD TIME WILL START UPON RECEIPT OF SIGNED APPROVAL DRAWING

DISTRIBUTOR'S NAME:		P.O.#
VESTIL MANUFACTURING		X
DRAWN BY: ND		DATE: 3/26/07
DATE: 3/26/07		SALES: X
REFERENCE: X	SCALE: 1:27	FILE NAME:
QUOTED LEAD TIME: X	QUOTE # X	28-007-037