

# ADJUSTABLE STEEL GANTRY CRANE - AHS-8-15-9

APPROX WEIGHT: 843.62 lbs.  
DOES NOT INCLUDE WEIGHT OF POWER OR PACKAGING!!!

\*\*\* ANY ADDITIONS, DELETIONS, OR OMISSIONS MUST BE CORRECTED ON THIS DRAWING AS THIS DRAWING WILL BE CONSIDERED ALL INCLUSIVE \*\*\*

ALL GRAPHICS PROVIDED ARE FOR REFERENCE ONLY. IF CERTAIN DIMENSIONS ARE CRITICAL PLEASE VERIFY THOSE DIMENSIONS WITH YOUR SALESPERSON

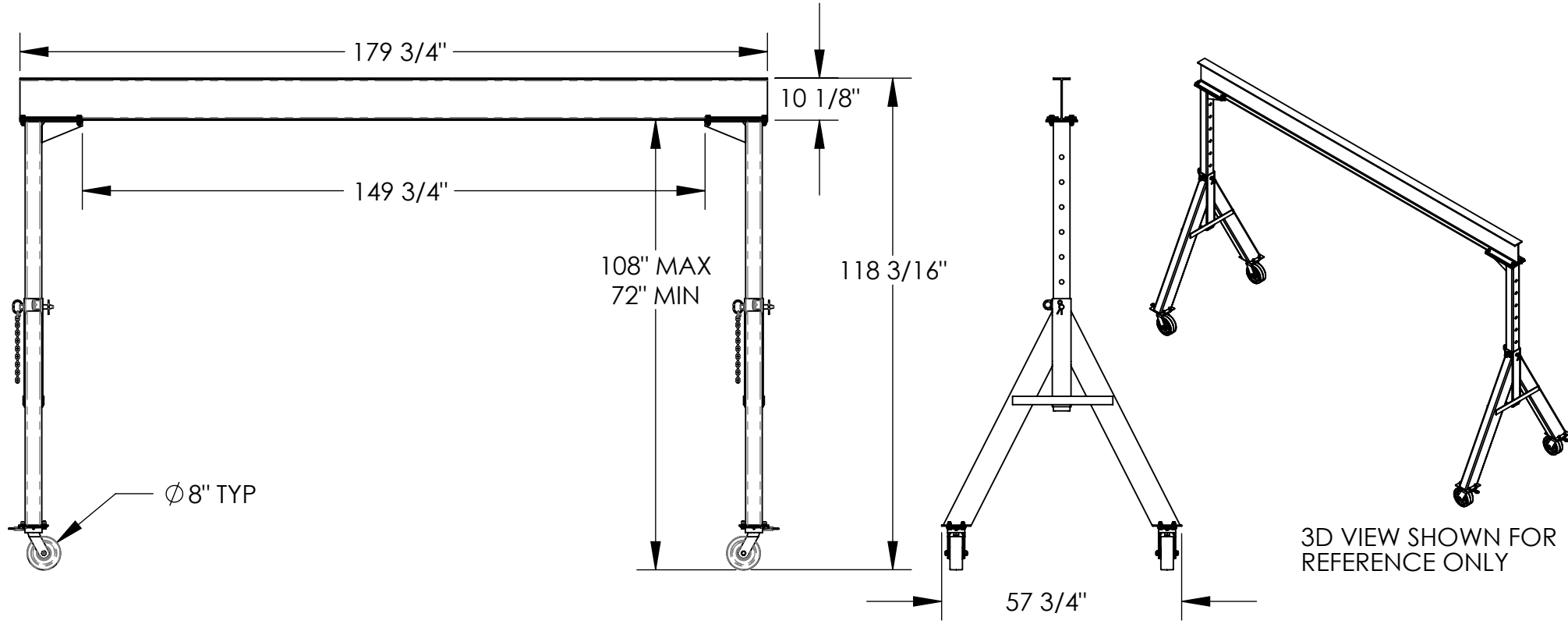

## STANDARD FEATURES

MODEL NUMBER IS AHS-8-15-9  
CAPACITY IS 8,000 LBS.  
BASE WIDTH IS 57 3/4"  
OVERALL HEIGHT IS 118 3/16"  
OVERALL I-BEAM LENGTH IS 179 3/4"  
USABLE I-BEAM LENGTH IS 149 3/4"  
ADJUSTABLE UNDER I-BEAM  
HEIGHT - 72" MIN. TO 108" MAX.  
I-BEAM HEIGHT IS 10 1/8"  
CASTERS: (4) 8" X 3" SWIVEL PHENOLIC  
WITH FOUR POSITION LOCKING

## SPECIAL FEATURES

NONE

## ADDITIONAL OPTIONS

MANUAL TROLLIES		
1,000 # CAPACITY	2,000 # CAPACITY	4,000 # CAPACITY
QIT-1	QIT-2	QIT-4
E-MT-1	E-MT-2	E-MT-4
E-MT-1-C	E-MT-2-C	E-MT-4-C
6,000 # CAPACITY	8,000 # CAPACITY	
QIT-6	QIT-8	
E-MT-6	E-MT-8	
E-MT-6-C	E-MT-8-C	

\*\*CAPACITY OF ATTACHMENTS MAY  
DERATE CAPACITY OF GANTRY CRANE

I, THE UNDERSIGNED, AGREE THAT THE PRODUCT AS REPRESENTED SATISFIES DESIGN AND DIMENSION REQUIREMENTS. I ALSO ACKNOWLEDGE MY DUTY TO CONFIRM PRODUCT AND INSTALLATION COMPLIANCE WITH ALL APPLICABLE FEDERAL, STATE AND LOCAL REGULATIONS AND STANDARDS.

**ALL SPECIAL UNITS ARE NON-RETURNABLE**  
[ ] As drawn [ ] As marked

Signed: \_\_\_\_\_ Date: \_\_\_\_\_

LEAD TIME WILL START UPON RECEIPT OF SIGNED APPROVAL DRAWING

**APPROVAL**

DISTRIBUTOR'S NAME: VESTIL MANUFACTURING P.O.# X

W.O.# X

SALES: X

FILE NAME: 28-007-213

DRAWN BY: ND DATE: 10/12/09

REFERENCE: X SCALE: 1:36

QUOTED LEAD TIME: X QUOTE # X