

ADJUSTABLE STEEL GANTRY CRANE - AHS-6-15-10

APPROX WEIGHT: 875.98 lbs. DOES NOT INCLUDE WEIGHT OF POWER OR PACKAGING!!!

*** ANY ADDITIONS, DELETIONS, OR OMISSIONS MUST BE CORRECTED ON THIS DRAWING AS THIS DRAWING WILL BE CONSIDERED ALL INCLUSIVE ***
 ALL GRAPHICS PROVIDED ARE FOR REFERENCE ONLY. IF CERTAIN DIMENSIONS ARE CRITICAL PLEASE VERIFY THOSE DIMENSIONS WITH YOUR SALESPERSON

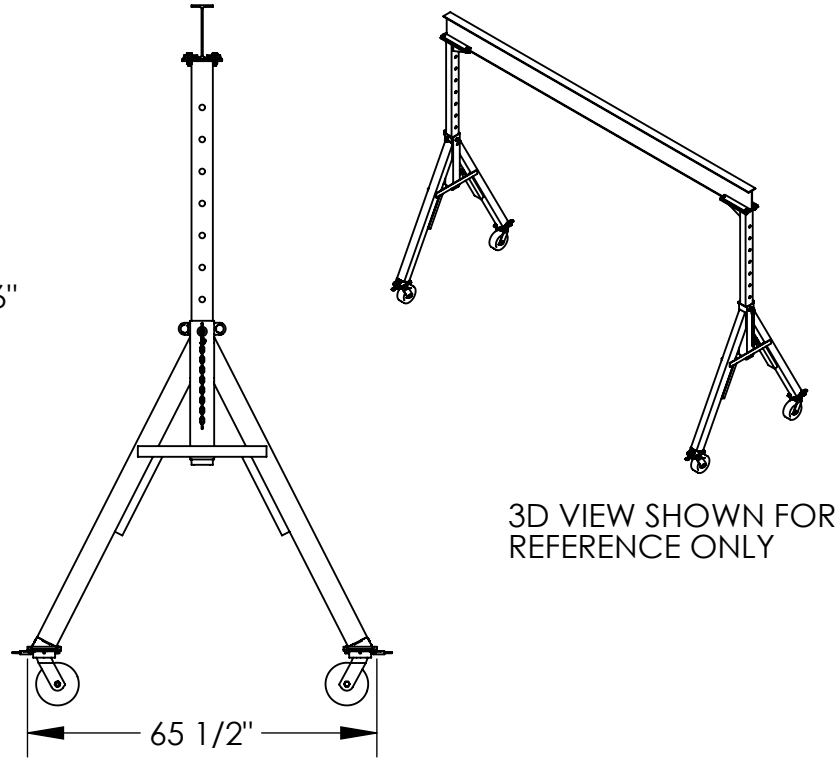
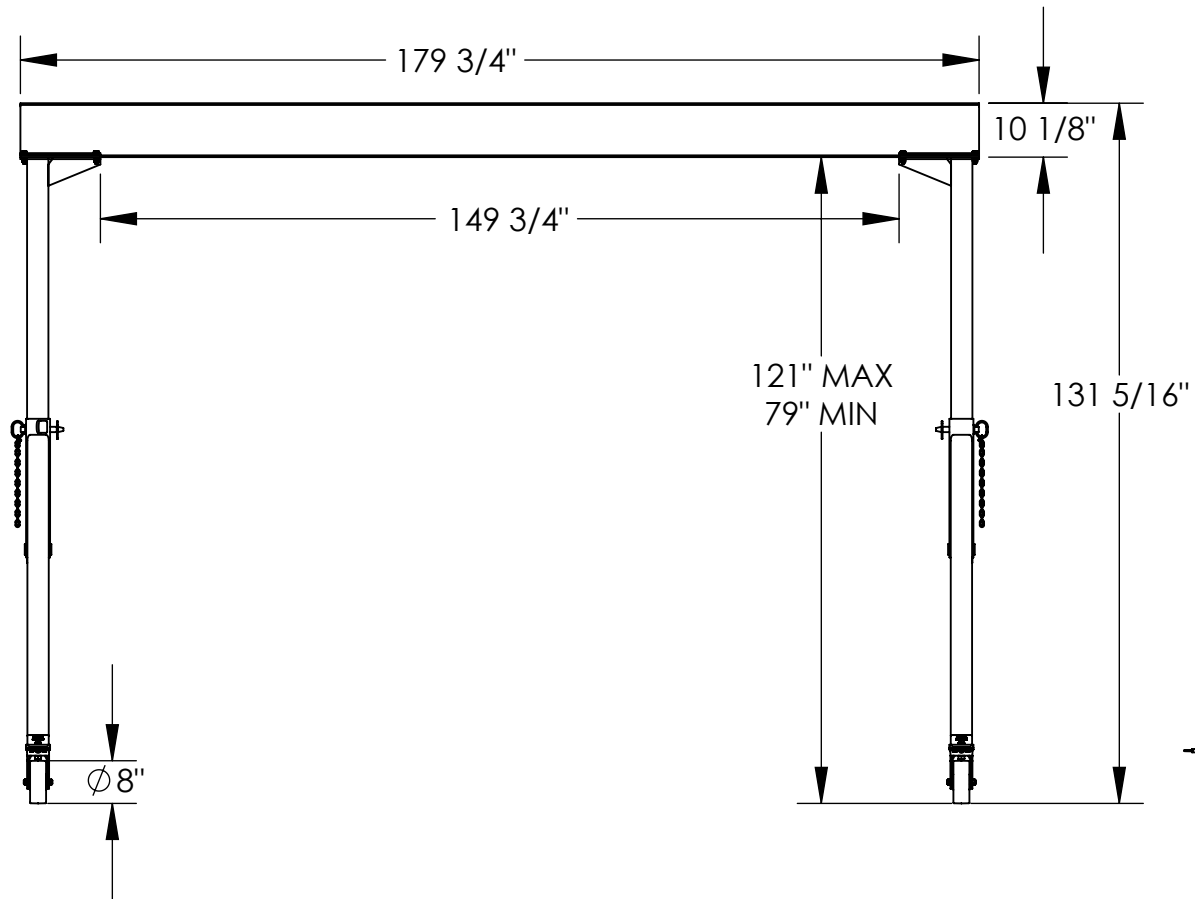

3D VIEW SHOWN FOR REFERENCE ONLY

STANDARD FEATURES

MODEL NUMBER IS AHS-6-15-10
 CAPACITY IS 6,000 LBS.
 BASE WIDTH IS 65 1/2"
 OVERALL HEIGHT IS 131 5/16"
 OVERALL I-BEAM LENGTH IS 179 3/4"
 USABLE I-BEAM LENGTH IS 149 3/4"
 ADJUSTABLE UNDER I-BEAM HEIGHT
 79" MIN. TO 121" MAX.
 I-BEAM HEIGHT IS 10 1/8"
 (4) Ø8" SWIVEL CASTERS WITH
 FOUR LOCKING POSITIONS

SPECIAL FEATURES

NONE

ADDITIONAL OPTIONS

MANUAL TROLLEYS			
1,000 # CAPACITY	2,000 # CAPACITY	4,000 # CAPACITY	6,000 # CAPACITY
QIT-1	QIT-2	QIT-4	QIT-6
E-MT-1	E-MT-2	E-MT-4	E-MT-6
E-MT-1-C	E-MT-2-C	E-MT-4-C	E-MT-6-C

**CAPACITY OF ATTACHMENTS MAY
 DERATE CAPACITY OF GANTRY CRANE

I, THE UNDERSIGNED, AGREE THAT THE PRODUCT AS REPRESENTED SATISFIES DESIGN AND DIMENSION REQUIREMENTS. I ALSO ACKNOWLEDGE MY DUTY TO CONFIRM PRODUCT AND INSTALLATION COMPLIANCE WITH ALL APPLICABLE FEDERAL, STATE AND LOCAL REGULATIONS AND STANDARDS.

ALL SPECIAL UNITS ARE NON-RETURNABLE
 As drawn As marked

Signed: _____ Date: _____

LEAD TIME WILL START UPON RECEIPT OF SIGNED APPROVAL DRAWING

DISTRIBUTOR'S NAME:		P.O.#
VESTIL MANUFACTURING		X
DRAWN BY: ND		W.O.#
DATE: 10/12/09		X
REFERENCE: X	SCALE: 1:36	SALES: X
QUOTED LEAD TIME: X	QUOTE # X	FILE NAME:
		28-007-208