

ADJUSTABLE STEEL GANTRY CRANE - AHS-4-15-16

APPROX WEIGHT: 977.64 lbs.
 DOES NOT INCLUDE WEIGHT OF POWER OR PACKAGING!!!

*** ANY ADDITIONS, DELETIONS, OR OMISSIONS MUST BE CORRECTED ON THIS DRAWING AS THIS DRAWING WILL BE CONSIDERED ALL INCLUSIVE ***

ALL GRAPHICS PROVIDED ARE FOR REFERENCE ONLY. IF CERTAIN DIMENSIONS ARE CRITICAL PLEASE VERIFY THOSE DIMENSIONS WITH YOUR SALESPERSON

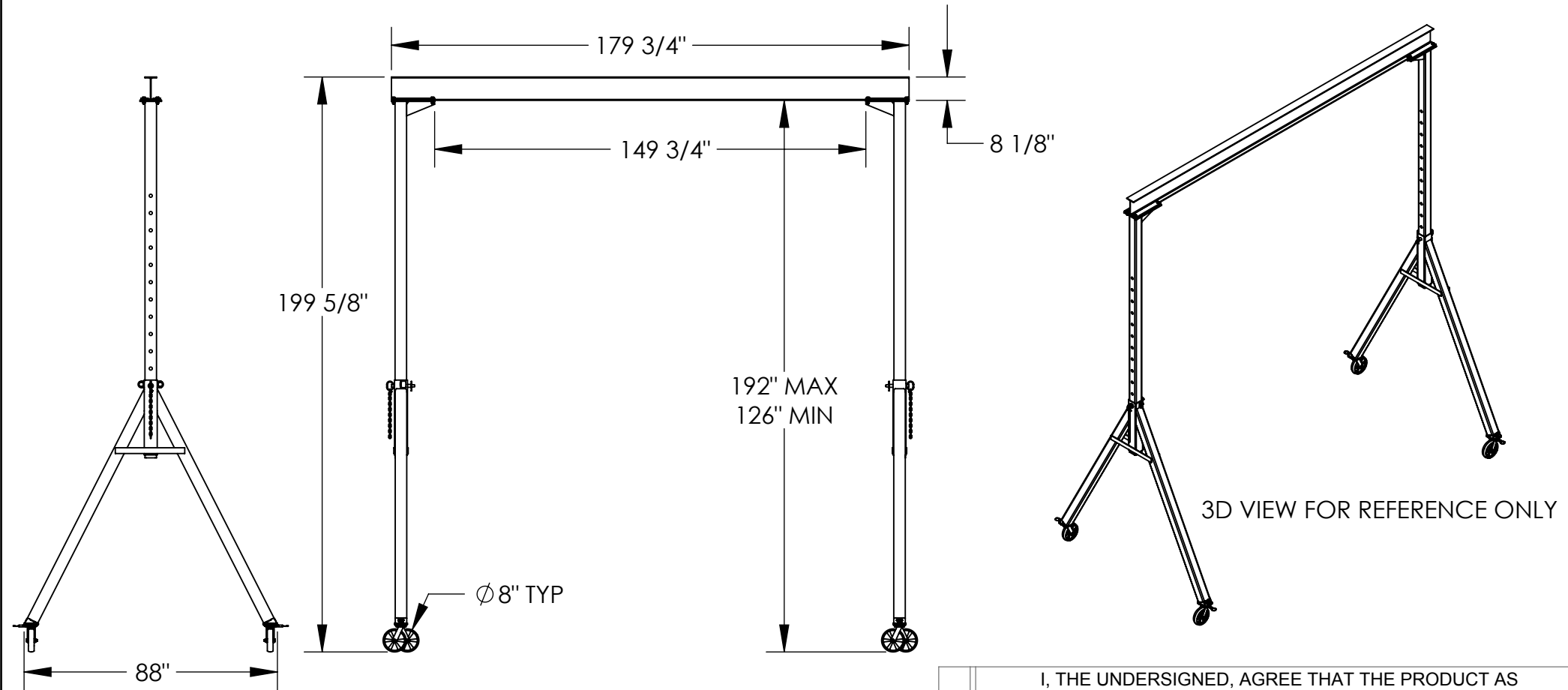

STANDARD FEATURES

MODEL NUMBER IS AHS-4-15-16
 CAPACITY IS 4,000 LBS.
 BASE WIDTH IS 88"
 OVERALL HEIGHT IS 199 5/8"
 OVERALL I-BEAM LENGTH IS 179 3/4"
 USABLE I-BEAM LENGTH IS 149 3/4"
 ADJUSTABLE UNDER I-BEAM
 HEIGHT - 126" MIN. TO 192" MAX.
 I-BEAM HEIGHT IS 8 1/8"
 (4) Ø8" SWIVEL CASTERS WITH
 FOUR LOCKING POSITIONS

ADDITIONAL OPTIONS

MANUAL TROLLIES		
1,000 # CAPACITY	2,000 # CAPACITY	4,000 # CAPACITY
QIT-1	QIT-2	QIT-4
E-MT-1	E-MT-2	E-MT-4
E-MT-1-C	E-MT-2-C	E-MT-4-C

**CAPACITY OF ATTACHMENTS MAY
 DERATE CAPACITY OF GANTRY CRANE

I, THE UNDERSIGNED, AGREE THAT THE PRODUCT AS REPRESENTED SATISFIES DESIGN AND DIMENSION REQUIREMENTS. I ALSO ACKNOWLEDGE MY DUTY TO CONFIRM PRODUCT AND INSTALLATION COMPLIANCE WITH ALL APPLICABLE FEDERAL, STATE AND LOCAL REGULATIONS AND STANDARDS.

ALL SPECIAL UNITS ARE NON-RETURNABLE
 As drawn As marked

Signed: _____ Date: _____

LEAD TIME WILL START UPON RECEIPT OF SIGNED APPROVAL DRAWING

APPROVAL	DISTRIBUTOR'S NAME:		P.O.#
	VESTIL MANUFACTURING		X
	DRAWN BY: ND	DATE: 10/1/09	W.O.#
			X
REFERENCE: X	SCALE: 1:50	SALES: X	FILE NAME:
QUOTED LEAD TIME: X	QUOTE # X	28-007-170	