

ADJUSTABLE STEEL GANTRY CRANE - AHS-2-10-16

APPROX WEIGHT: 871.96 lbs.
 DOES NOT INCLUDE WEIGHT OF POWER OR PACKAGING!!!

*** ANY ADDITIONS, DELETIONS, OR OMISSIONS MUST BE CORRECTED ON THIS DRAWING AS THIS DRAWING WILL BE CONSIDERED ALL INCLUSIVE ***

ALL GRAPHICS PROVIDED ARE FOR REFERENCE ONLY. IF CERTAIN DIMENSIONS ARE CRITICAL PLEASE VERIFY THOSE DIMENSIONS WITH YOUR SALESPERSON

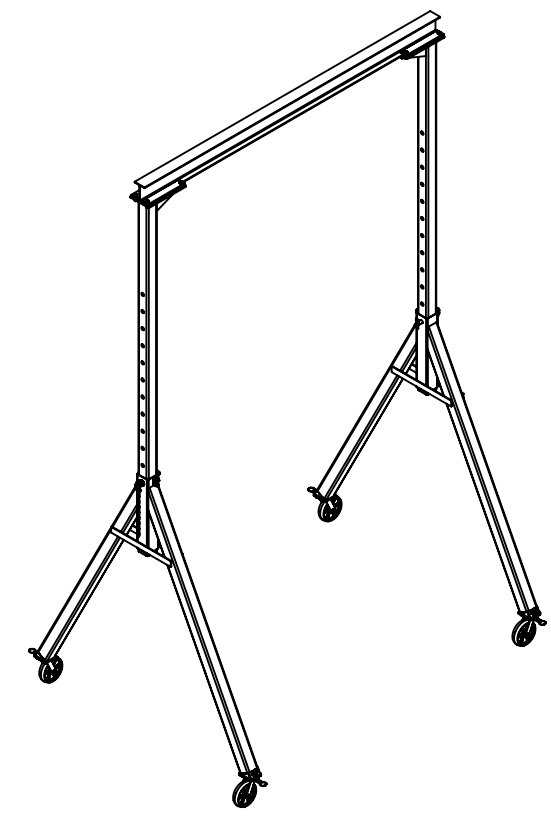
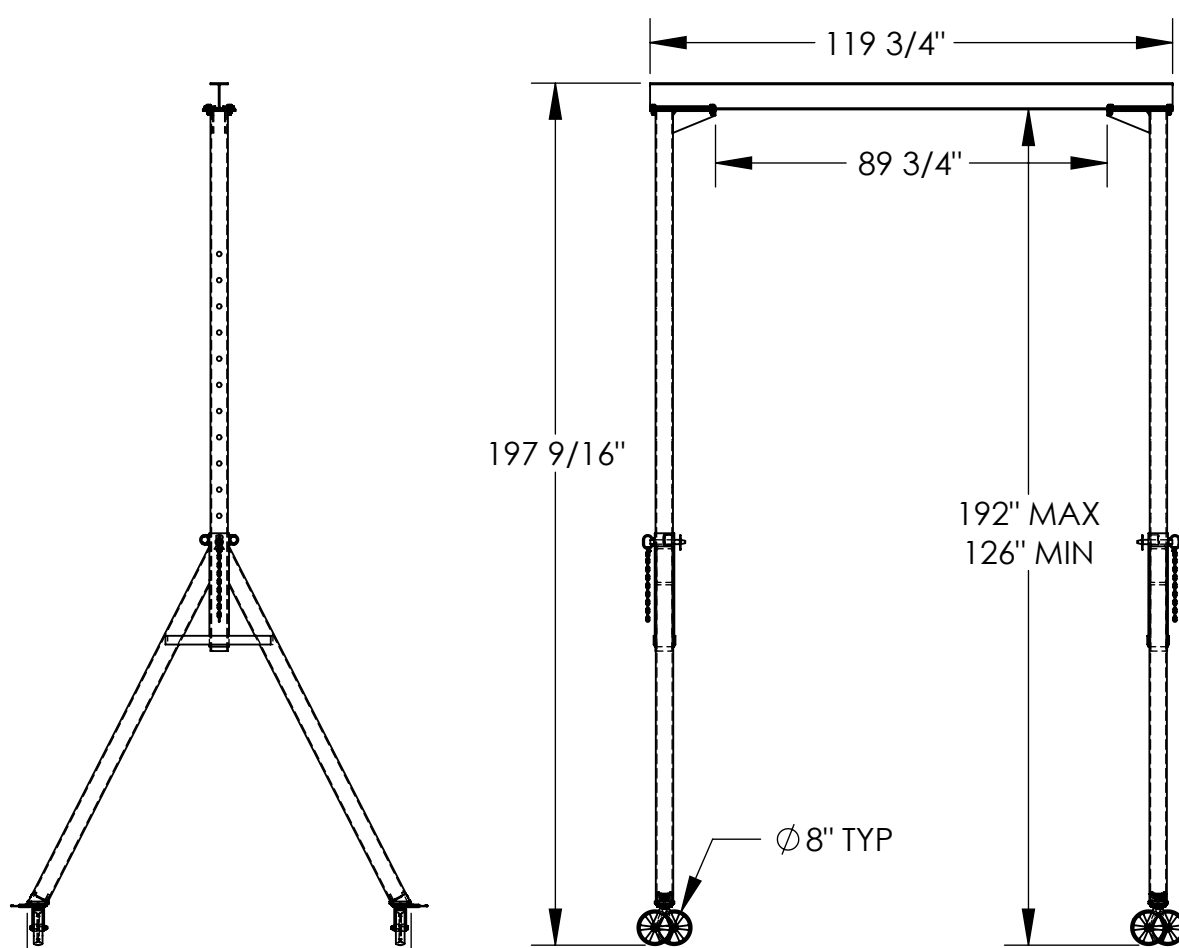

3D VIEW FOR REFERENCE ONLY

STANDARD FEATURES

- MODEL NUMBER IS AHS-2-10-16
- CAPACITY IS 2,000 LBS.
- BASE WIDTH IS 88"
- OVERALL HEIGHT IS 197 9/16"
- OVERALL I-BEAM LENGTH IS 119 3/4"
- USABLE I-BEAM LENGTH IS 89 3/4"
- ADJUSTABLE UNDER I-BEAM
- HEIGHT - 126" MIN. TO 192" MAX.
- I-BEAM HEIGHT IS 6"
- (4) Ø8" SWIVEL CASTERS WITH FOUR LOCKING POSITIONS

ADDITIONAL OPTIONS

MANUAL TROLRIES	
1,000 # CAPACITY	2,000 # CAPACITY
QIT-1	QIT-2
E-MT-1	E-MT-2
E-MT-1-C	E-MT-2-C

**CAPACITY OF ATTACHMENTS MAY DERATE CAPACITY OF GANTRY CRANE

I, THE UNDERSIGNED, AGREE THAT THE PRODUCT AS REPRESENTED SATISFIES DESIGN AND DIMENSION REQUIREMENTS. I ALSO ACKNOWLEDGE MY DUTY TO CONFIRM PRODUCT AND INSTALLATION COMPLIANCE WITH ALL APPLICABLE FEDERAL, STATE AND LOCAL REGULATIONS AND STANDARDS.

ALL SPECIAL UNITS ARE NON-RETURNABLE
 As drawn As marked

Signed: _____ Date: _____

LEAD TIME WILL START UPON RECEIPT OF SIGNED APPROVAL DRAWING

DISTRIBUTOR'S NAME:		P.O.#
VESTIL MANUFACTURING		X
DRAWN BY: ND	DATE: 10/1/09	W.O.#
REFERENCE: X	SCALE: 1:44	X
QUOTED LEAD TIME: X	QUOTE #	SALES: X
	X	FILE NAME:
		28-007-166