



AL Series Hoists

Features

Certified Spark Resistant for Safe Operation

All hoists are  certified spark resistant (Explosive atmospheres that require features that reduce the risk of spark) to level  II 2GD c T5 IIB T100°C and are in compliance with the EU ATEX Directive. (See page 17 for more information.)



Lubrication Free

AL series air hoists are suitable for applications where a clean environment is a necessity. The hoists can operate completely dry leaving no lubrication in the exhaust air and are typically used in the food, chemical and pharmaceutical industries. (Note: Hoists can also operate with oil for longer vane life.)



Heavy-Duty Disk Brake

Harrington's patented self-adjusting disk brake mechanism eliminates load drift and ensures fine feathering control.



Vane Motor

Permits smooth operation and controlled travel.



Surface Hardened Steel Load Chain

Zinc-plated and blue-chromated for corrosion resistance and extended wear.



Bearing Supported Planetary Gearing System

For continuous operation at full load.



Lightweight and Compact Body

Allows for easy operation, transportation and provides exceptional headroom.



Hook and Latch System

Zinc-plated and blue-chromated and swivel 360 degrees.



AL Series Hoists

Bearing Supported Planetary Gearing System

For continuous operation at full load.

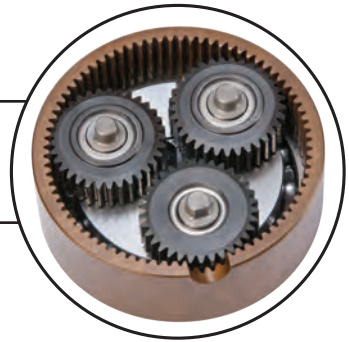

Heavy-Duty Disk Brake

Harrington's patented disk brake mechanism eliminates load drift and ensures fine feathering control.

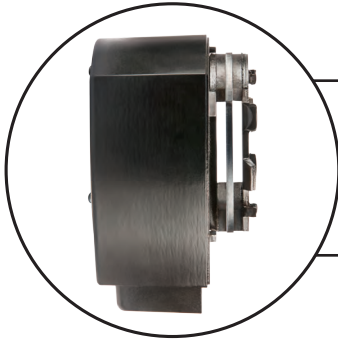

⊕ Certified Spark Resistant for Safe Operation

All hoists are ⊕ certified spark resistant (Explosive atmospheres that require features that reduce the risk of spark) to level ⊕ II 2GD c T5 IIB T100°C and are in compliance with the EU ATEX Directive. (See page 17 for more information.)

Lightweight and Compact Body

Allows for easy operation, transportation and provides exceptional headroom.

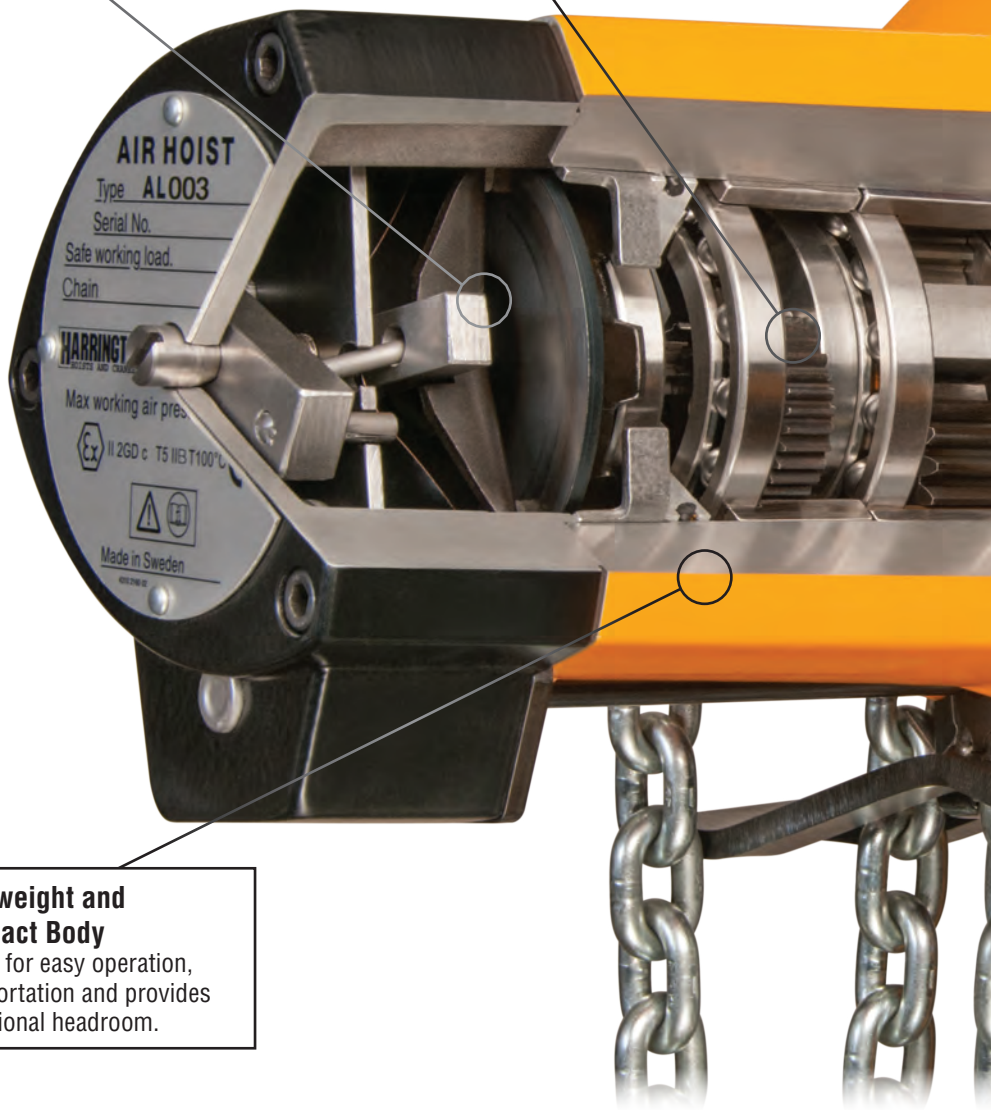

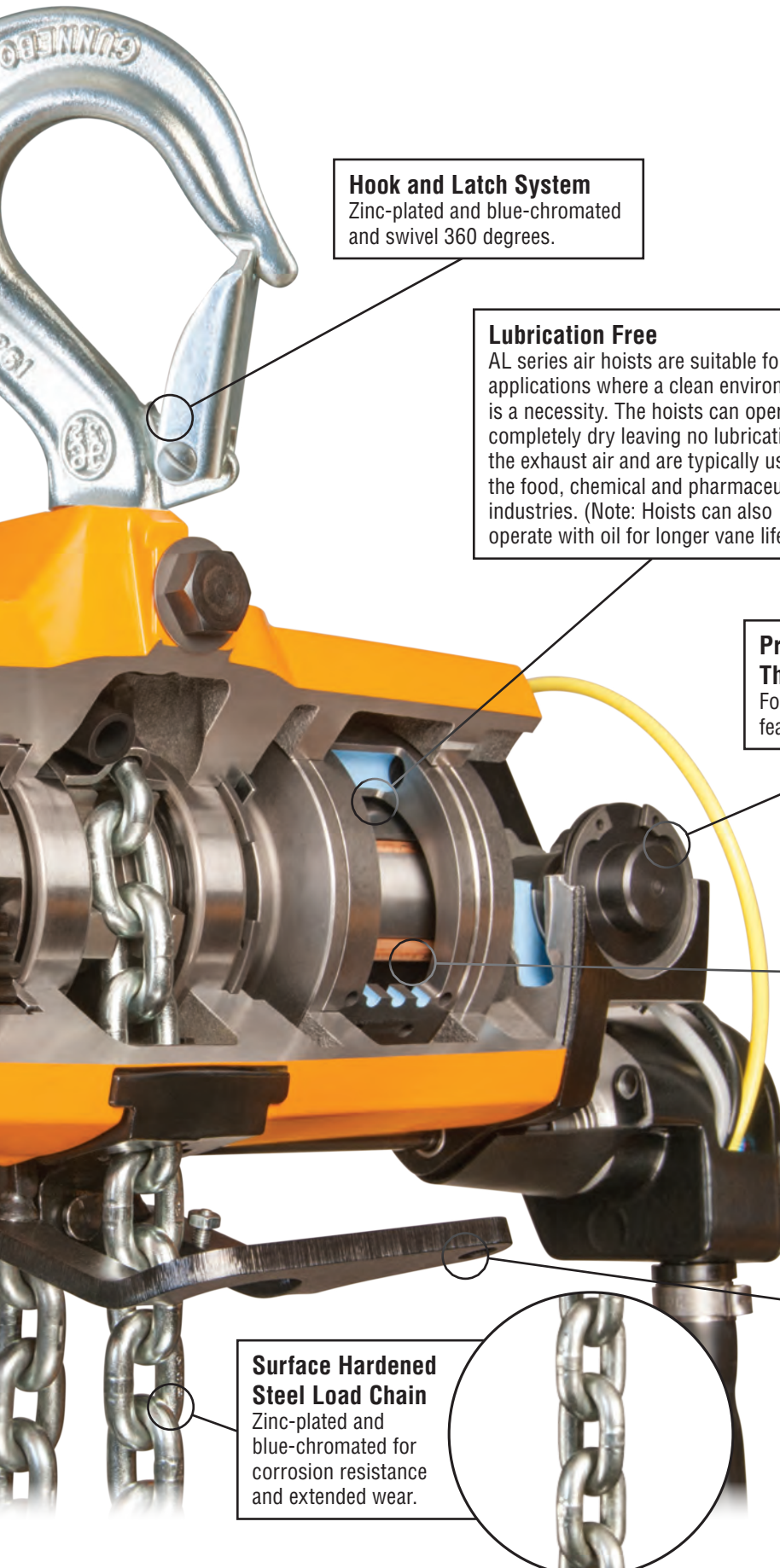

Hook and Latch System
Zinc-plated and blue-chromated and swivel 360 degrees.

Lubrication Free
AL series air hoists are suitable for applications where a clean environment is a necessity. The hoists can operate completely dry leaving no lubrication in the exhaust air and are typically used in the food, chemical and pharmaceutical industries. (Note: Hoists can also operate with oil for longer vane life.)

Precision Throttle Valve
For outstanding feathering control.

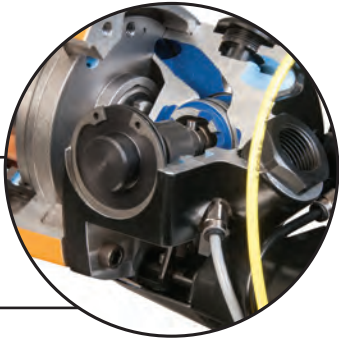

Vane Motor
Permits smooth operation and controlled travel.

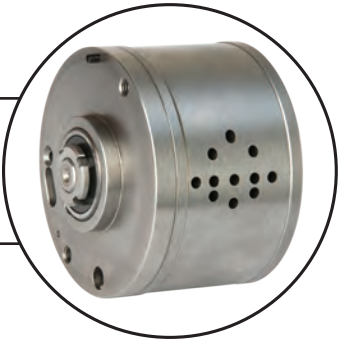

Limit Switches
Upper / lower limit switches are standard for hoist protection.





Surface Hardened Steel Load Chain
Zinc-plated and blue-chromated for corrosion resistance and extended wear.





AL Certified Spark Resistant and Lube Free Air Hoists with Pendant and Cord Controls and Hook Suspension



Harrington's AL Series  certified spark resistant and lube free air hoists can operate without air supply lubrication which leaves the surrounding environment free of oil mist from the air exhaust. Built for precise load positioning with pendant, cord or twist rod control this hoist is perfect for use in food, chemical and pharmaceutical industries or in any area where oil mist cannot be tolerated. Hoists can also operate with oil for longer vane life. All hoists are  certified spark resistant to level  II 2GD c T5 IIB T100°C and are in compliance with the EU ATEX Directive.

Features and Benefits

Certified Spark Resistant for Safe Operation

All hoists are  certified spark resistant (Explosive atmospheres that require features that reduce the risk of spark) to level  II 2GD c T5 IIB T100°C and are in compliance with the EU ATEX Directive. (See page 17 for more information.)

Lubrication Free

AL series air hoists are suitable for applications where a clean environment is a necessity. The hoists can operate completely dry leaving no lubrication in the exhaust air and are typically used in the food, chemical and pharmaceutical industries. (Note: Hoists can also operate with oil for longer vane life.)

Heavy-Duty Disk Brake

Harrington's patented disk brake mechanism eliminates load drift and ensures fine feathering control.

Vane Motor

Permits smooth operation and controlled travel.

Surface Hardened Steel Load Chain

Zinc-plated and blue-chromated for corrosion resistance and extended wear.

Bearing Supported Planetary Gearing System

For continuous operation at full load.

Lightweight and Compact Body

Allows for easy operation, transportation and provides exceptional headroom.

Hook and Latch System

Zinc-plated and blue-chromated and swivel 360 degrees.

Standard Hoist Specifications

Capacity Range

¼ - 5 Ton

Standard Lift

10' (longer lengths available)

Duty Cycle

Unlimited

Pendant or Cord Length

4' less than lift
(longer lengths available)

Air Filtration

Maximum 30 micron air filter or finer

Air Supply Requirement

90 PSI

Air Inlet Port

½" NPT

Air Supply Hose Minimum Size

½"

Operating Conditions

Temperature Range +14° to 104° F
Humidity 85% or less

Options

Canvas Chain Container
Steel Chain Container
Twist Rod
Self-locking Hooks
Filter, Lubricator, Regulator
Load Limiter
Additional spark resistant components—consult Customer Service

HARRINGTON  **CERTIFIED SPARK RESISTANT AND LUBE FREE AIR HOISTS**

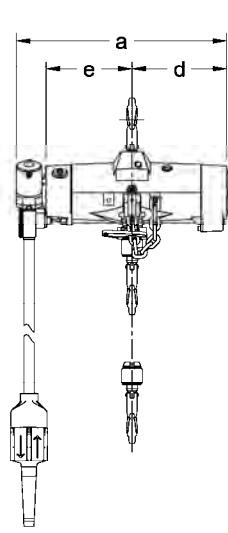

AL003P

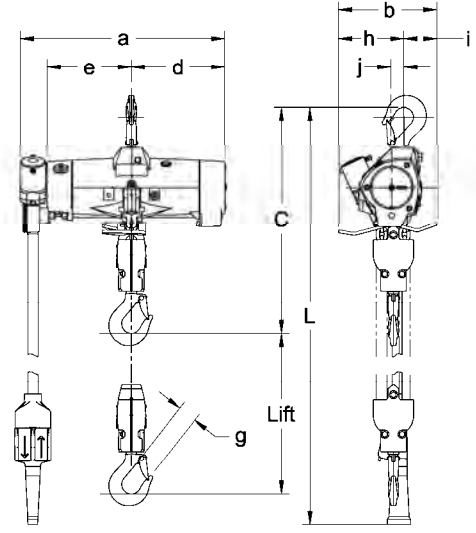

AL010P2

AL PENDANT MODEL—SPECIFICATIONS

Cap. (Tons)	Product Code	Standard Lift (ft)	Push Button Hose L (ft)	Up/Down Speeds (ft/min @ 90psi)		Up/Down Air Consumption Rates (cubic ft/min @ 90 psi)		Load Chain Diameter (mm) x Chain Fall Lines	Net Weight (lbs)	Weight for Additional One Foot of Lift (lbs)
				No Load	w/Full Load	No Load	w/Full Load			
1/4	AL003P	10	7.5	85 / 66	61 / 105	98 / 64	78 / 72	6.5x1	39	0.6
1/2	AL005P			78 / 49	41 / 72	102 / 68	81 / 74	6.5x1	39	0.6
1	AL010P2			39 / 25	21 / 36	102 / 68	81 / 74	6.5x2	55	0.6
3	AL030P			20 / 18	10 / 20	102 / 76	85 / 81	11.5x1	123	1.9
5	AL050P2		8.6	9.8 / 8.9	5.2 / 9.8	102 / 76	85 / 81	11.5x2	234	1.9

AL PENDANT MODEL—DIMENSIONS

Capacity (Tons)	Product Code	Headroom C (in)	a (in)	b (in)	d (in)	e (in)	g (in)	h (in)	i (in)	j (in)
1/4	AL003P	14.8	15.9	7.7	7.2	6.6	1.1	4.8	2.9	0.7
1/2	AL005P	14.8	15.9	7.7	7.2	6.6	1.1	5.1	2.6	1.0
1	AL010P2	17.5	15.9	7.7	7.2	6.6	1.1	5.1	2.6	1.0
3	AL030P	22.6	22.0	13.7	10.4	9.6	2.0	7.8	5.9	1.5
5	AL050P2	30.9	22.0	13.7	10.4	9.6	2.4	8.9	4.7	2.7

AL  Certified Spark Resistant and Lube Free Air Hoists with Pendant and Cord Controls and Hook Suspension

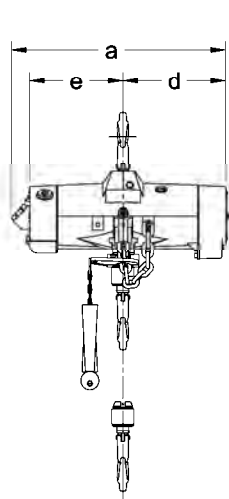

AL003C

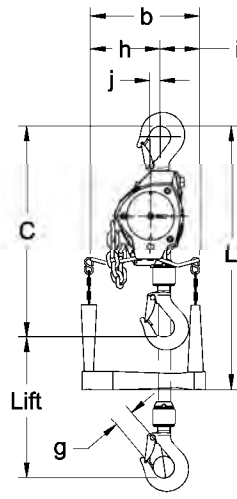

AL010C2

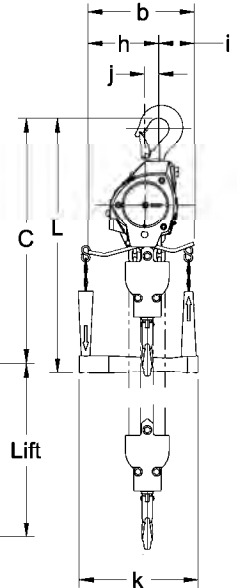
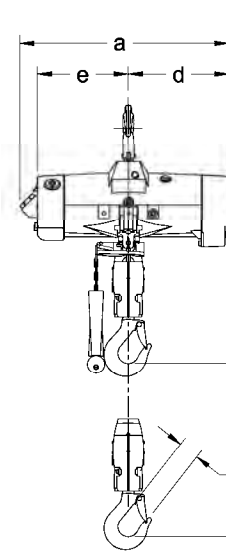

AL CORD MODEL—SPECIFICATIONS

Cap. (Tons)	Product Code	Standard Lift (ft)	Cord L (ft)	Up/Down Speeds (ft/min @ 90psi)		Up/Down Air Consumption Rates (cubic ft/min @ 90 psi)		Load Chain Diameter (mm) x Chain Fall Lines	Net Weight (lbs)	Weight for Additional One Foot of Lift (lbs)
				No Load	w/Full Load	No Load	w/Full Load			
1/4	AL003C	10	7.5	85 / 66	61 / 105	98 / 64	78 / 72	6.5x1	37.5	0.6
1/2	AL005C			78 / 49	41 / 72	102 / 68	81 / 74	6.5x1	37.5	0.6
1	AL010C2			39 / 25	21 / 36	102 / 68	81 / 74	6.5x2	53	0.6
3	AL030C			20 / 18	10 / 20	102 / 76	85 / 81	11.5x1	121	1.9
5	AL050C2		8.6	9.8 / 8.9	5.2 / 9.8	102 / 76	85 / 81	11.5x2	232	1.9

For optional Twist Rod Control – Rod L = 3.5 to 6.5 feet.

AL CORD MODEL—DIMENSIONS

Capacity (Tons)	Product Code	Headroom C (in)	a (in)	b (in)	d (in)	e (in)	g (in)	h (in)	i (in)	j (in)	k (in)
1/4	AL003C	14.8	15.4	7.7	7.2	6.7	1.1	4.8	2.9	0.7	8.7
1/2	AL005C	14.8	15.4	7.7	7.2	6.7	1.1	5.1	2.6	1.0	8.7
1	AL010C2	17.5	15.4	7.7	7.2	6.7	1.1	5.1	2.6	1.0	8.7
3	AL030C	22.6	21.5	13.7	10.4	9.6	2.0	7.8	5.9	1.5	8.7
5	AL050C2	30.9	21.5	13.7	10.4	9.6	2.4	8.9	4.7	2.7	8.7