

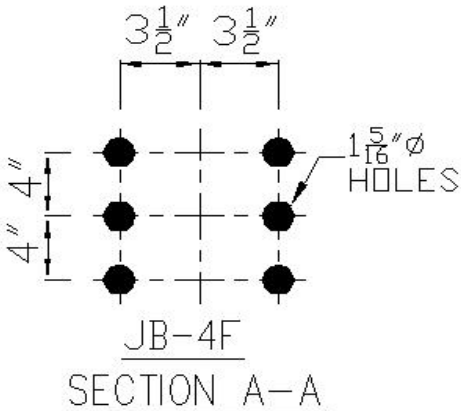

ABELL-HOWE CRANES
 DIVISION OF CRANE, EQUIPMENT & SERVICE, INC.
 10321 WERCH DR. UNIT 100, WOODRIDGE, ILLINOIS 60517

J-900 WALL BRACKET JIB CRANE
 GENERAL ARRANGEMENT
 JB-4F FABRICATED FITTINGS

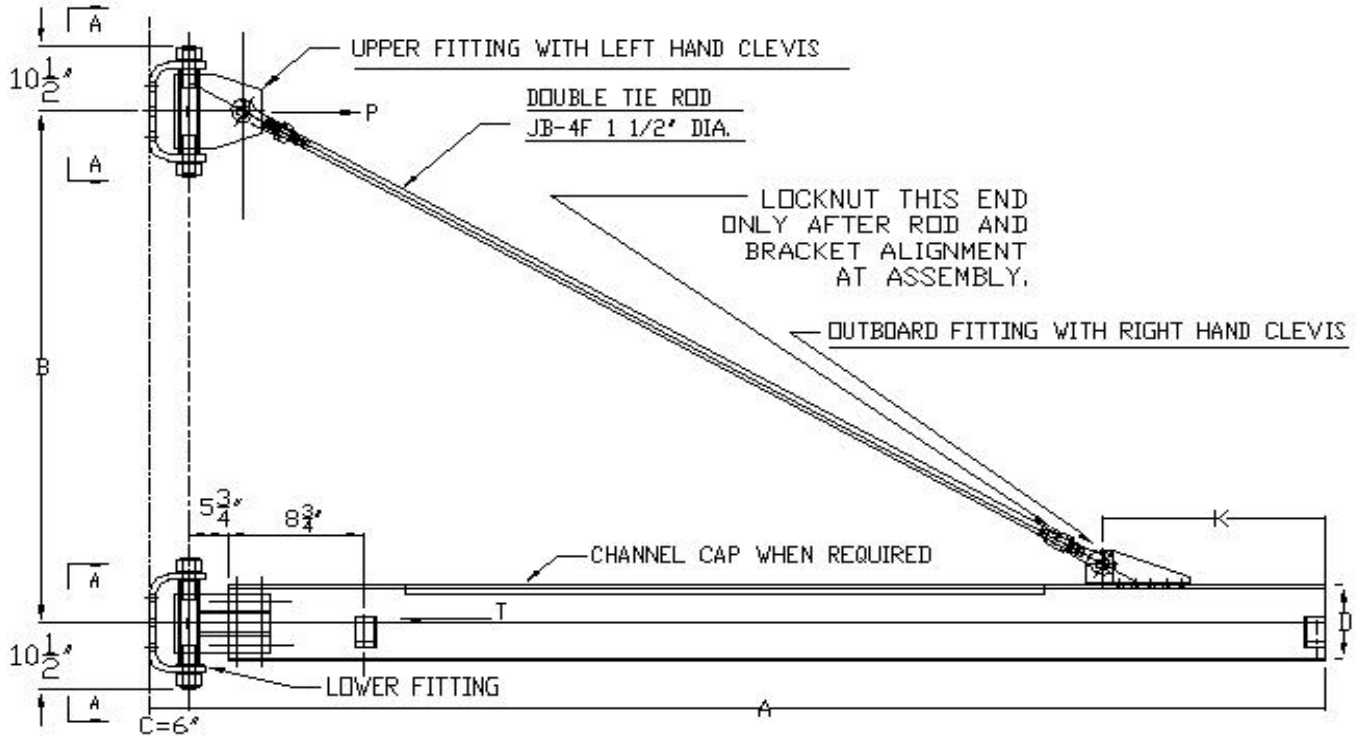

MODEL:	<u>900055</u>
CAPACITY:	<u>5 TON (10,000 #)</u>
A:	<u>20' 0"</u>
B:	<u>7' 0"</u>
C:	<u>6"</u>
D:	<u>W16X45 - D 16 1/8", FW 7"</u>
K:	<u>3' 6"</u>
NET WEIGHT:	<u>2082</u>

NOTE; JIB ASSEMBLY BOLTS & COLUMN CONNECTION BOLTS.
 TO BE ASTM-A-325 PER A-H CO. RECOMMENDATION.

ABELL-HOWE CRANES, ASSUMES NO RESPONSIBILITY FOR LOADING IMPOSED ON BUILDING STRUCTURE OR FOOTINGS BY THIS EQUIPMENT. WE SUGGEST THIS BE CHECKED BY A LICENSED STRUCTURAL ENGINEER AND ANY NECESSARY PERMITS BE SECURED.

SALES NO: _____
 CUST. ORDER NO: _____
 CUSTOMER: _____
 SHIP TO: _____

P = MAX. PULL = 36150
 T = MAX. THRUST = 36150