



**ABELL-HOWE CRANES**

DIVISION OF CRANE, EQUIPMENT & SERVICE, INC.  
 10321 WERCH DR. UNIT 100, WOODRIDGE, ILLINOIS 60517

**J-900 WALL BRACKET JIB CRANE**

GENERAL ARRANGEMENT  
 JB-3F FABRICATED FITTINGS

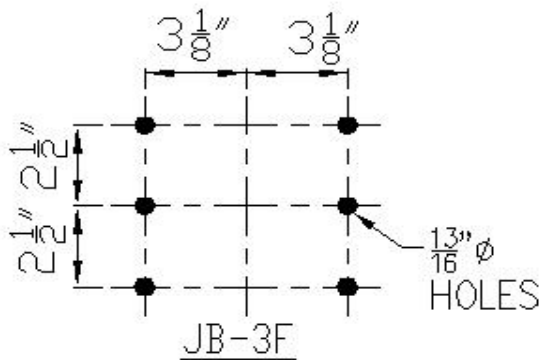
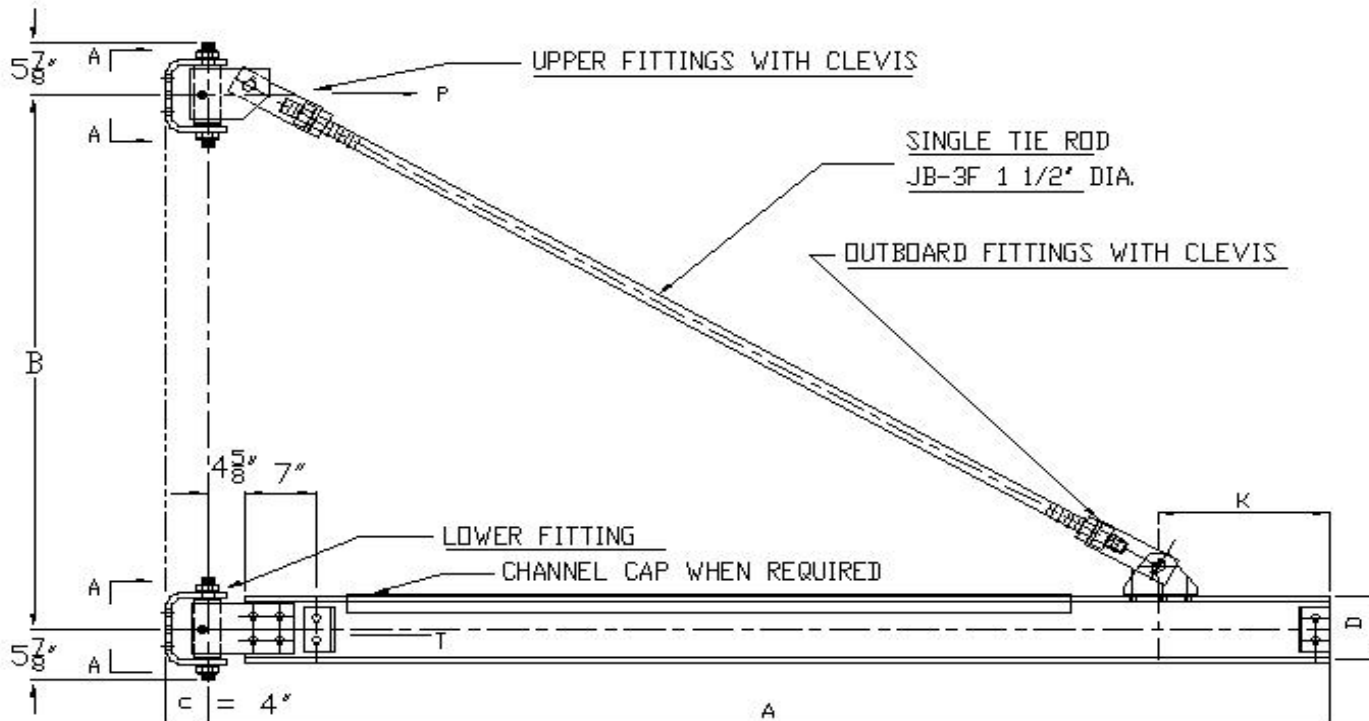

SECTION A-A

NOTE: JIB ASSEMBLY BOLTS & COLUMN CONNECTION BOLTS.  
 TO BE ASTM-A-325 PER A-H CO. RECOMMENDATION.

ABELL-HOWE CRANES, ASSUMES NO RESPONSIBILITY FOR LOADING IMPOSED ON BUILDING STRUCTURE OR FOOTINGS BY THIS EQUIPMENT. WE SUGGEST THIS BE CHECKED BY A LICENSED STRUCTURAL ENGINEER AND ANY NECESSARY PERMITS BE SECURED.

MODEL:	900048
CAPACITY:	3 TON (6,000 #)
A:	30' 0"
B:	11' 0"
C:	4"
D:	12X35 - D 12 1/2", FW 6 1/2" W/C
K:	3' 0"
NET WEIGHT:	1724

SALES NO: \_\_\_\_\_

CUST. ORDER NO: \_\_\_\_\_

CUSTOMER: \_\_\_\_\_

SHIP TO: \_\_\_\_\_

\_\_\_\_\_

\_\_\_\_\_

P = MAX. PULL = 21480

T = MAX. THRUST = 21480