

ADJUSTABLE STEEL GANTRY CRANE - AHS-6-15-12

APPROX WEIGHT: 953.50 lbs.
DOES NOT INCLUDE WEIGHT OF POWER OR PACKAGING!!!

*** ANY ADDITIONS, DELETIONS, OR OMISSIONS MUST BE CORRECTED ON THIS DRAWING AS THIS DRAWING WILL BE CONSIDERED ALL INCLUSIVE ***

ALL GRAPHICS PROVIDED ARE FOR REFERENCE ONLY. IF CERTAIN DIMENSIONS ARE CRITICAL PLEASE VERIFY THOSE DIMENSIONS WITH YOUR SALESPERSON

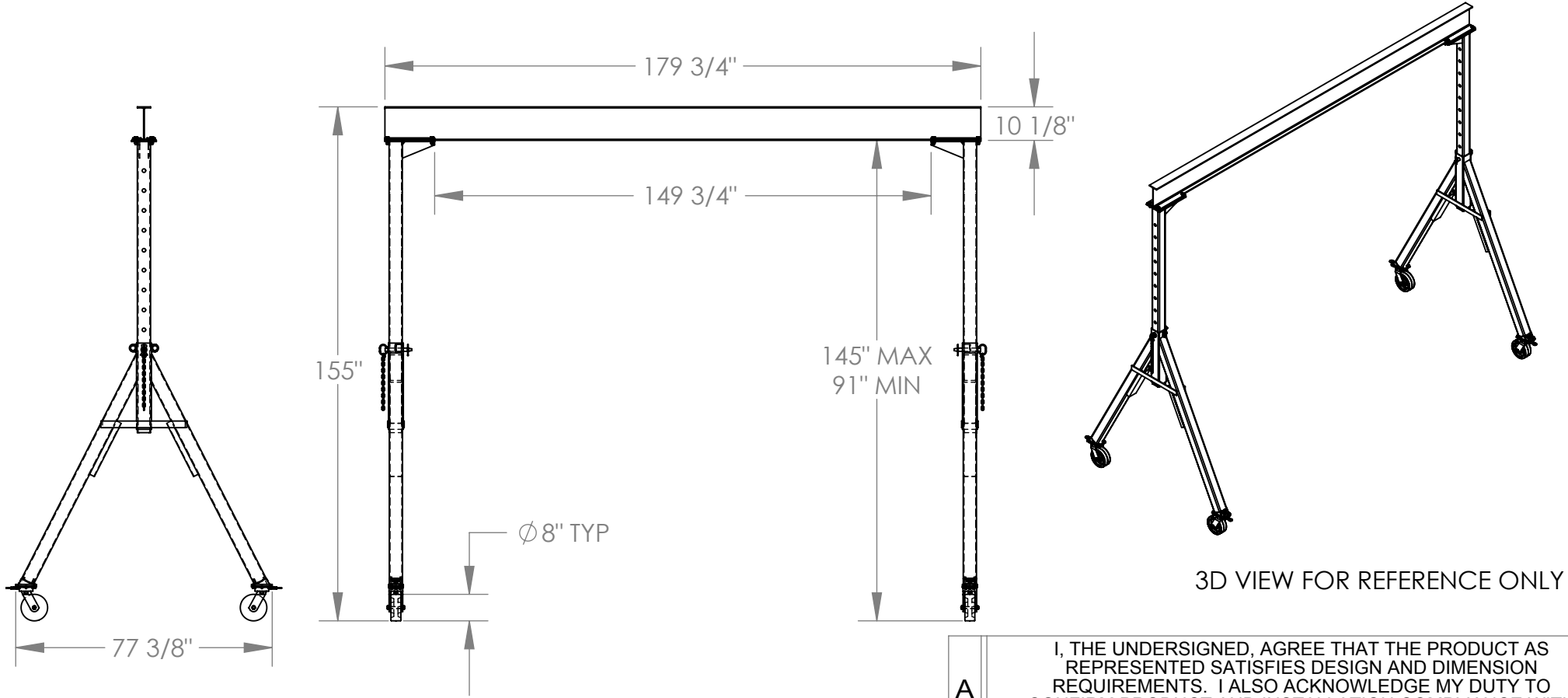

3D VIEW FOR REFERENCE ONLY

STANDARD FEATURES

- MODEL NUMBER IS AHS-6-15-12
- CAPACITY IS 6,000 LBS.
- BASE WIDTH IS 77 3/8"
- OVERALL HEIGHT IS 155"
- OVERALL I-BEAM LENGTH IS 179 3/4"
- USABLE I-BEAM LENGTH IS 149 3/4"
- ADJUSTABLE UNDER I-BEAM
- HEIGHT - 91" MIN. TO 145" MAX.
- I-BEAM HEIGHT IS 10 1/8"
- (4) Ø8" SWIVEL CASTERS WITH FOUR LOCKING POSITIONS

ADDITIONAL OPTIONS

MANUAL TROLLEYS	
1,000 # CAPACITY	2,000 # CAPACITY
QIT-1	QIT-2
E-MT-1	E-MT-2
E-MT-1-C	E-MT-2-C
4,000 # CAPACITY	6,000 # CAPACITY
QIT-4	QIT-6
E-MT-4	E-MT-6
E-MT-4-C	E-MT-6-C

**CAPACITY OF ATTACHMENTS MAY DERATE CAPACITY OF GANTRY CRANE

I, THE UNDERSIGNED, AGREE THAT THE PRODUCT AS REPRESENTED SATISFIES DESIGN AND DIMENSION REQUIREMENTS. I ALSO ACKNOWLEDGE MY DUTY TO CONFIRM PRODUCT AND INSTALLATION COMPLIANCE WITH ALL APPLICABLE FEDERAL, STATE AND LOCAL REGULATIONS AND STANDARDS.

ALL SPECIAL UNITS ARE NON-RETURNABLE
[] As drawn [] As marked

Signed: _____ Date: _____

LEAD TIME WILL START UPON RECEIPT OF SIGNED APPROVAL DRAWING

DISTRIBUTOR'S NAME:		P.O.#
VESTIL MANUFACTURING		X
DRAWN BY: ND		W.O.#
DATE: 10/1/09		X
REFERENCE: X	SCALE: 1:45	SALES: X
QUOTED LEAD TIME: X	QUOTE # X	FILE NAME:
		28-007-082