

# ADJUSTABLE STEEL GANTRY CRANE - AHS-6-10-14

APPROX WEIGHT: 950.12 lbs.  
 DOES NOT INCLUDE WEIGHT OF POWER OR PACKAGING!!!

\*\*\* ANY ADDITIONS, DELETIONS, OR OMISSIONS MUST BE CORRECTED ON THIS DRAWING AS THIS DRAWING WILL BE CONSIDERED ALL INCLUSIVE \*\*\*

ALL GRAPHICS PROVIDED ARE FOR REFERENCE ONLY. IF CERTAIN DIMENSIONS ARE CRITICAL PLEASE VERIFY THOSE DIMENSIONS WITH YOUR SALESPERSON

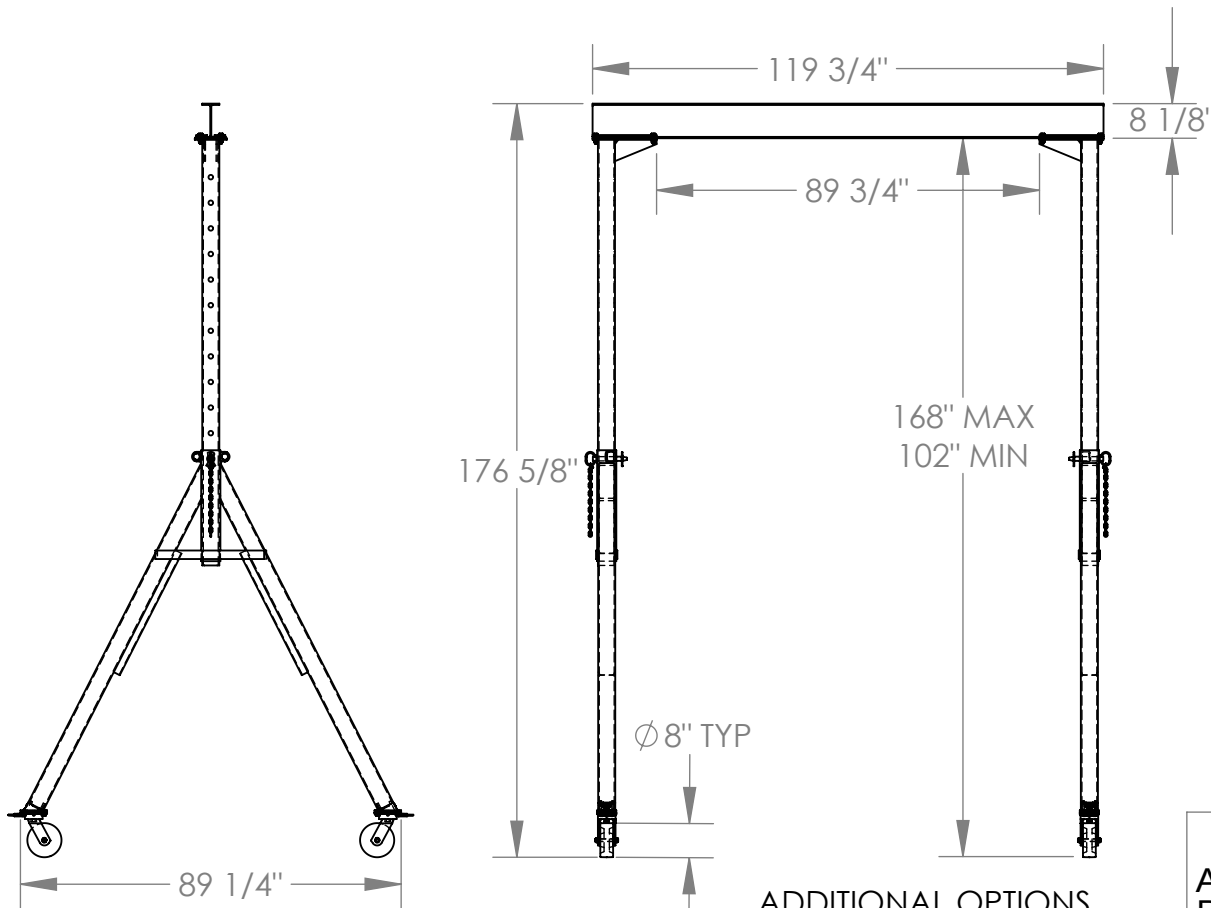

3D VIEW FOR REFERENCE ONLY

## STANDARD FEATURES

- MODEL NUMBER IS AHS-6-10-14
- CAPACITY IS 6,000 LBS.
- BASE WIDTH IS 89 1/4"
- OVERALL HEIGHT IS 176 5/8"
- OVERALL I-BEAM LENGTH IS 119 3/4"
- USABLE I-BEAM LENGTH IS 89 3/4"
- ADJUSTABLE UNDER I-BEAM
- HEIGHT - 102" MIN. TO 168" MAX.
- I-BEAM HEIGHT IS 8 1/8"
- (4) Ø8" SWIVEL CASTERS WITH FOUR LOCKING POSITIONS

## ADDITIONAL OPTIONS

MANUAL TROLLEYS	
1,000 # CAPACITY	2,000 # CAPACITY
QIT-1	QIT-2
E-MT-1	E-MT-2
E-MT-1-C	E-MT-2-C
4,000 # CAPACITY	6,000 # CAPACITY
QIT-4	QIT-6
E-MT-4	E-MT-6
E-MT-6-C	E-MT-6-C

\*\*CAPACITY OF ATTACHMENTS MAY DERATE CAPACITY OF GANTRY CRANE

APPROVAL

I, THE UNDERSIGNED, AGREE THAT THE PRODUCT AS REPRESENTED SATISFIES DESIGN AND DIMENSION REQUIREMENTS. I ALSO ACKNOWLEDGE MY DUTY TO CONFIRM PRODUCT AND INSTALLATION COMPLIANCE WITH ALL APPLICABLE FEDERAL, STATE AND LOCAL REGULATIONS AND STANDARDS.

**ALL SPECIAL UNITS ARE NON-RETURNABLE**  
 As drawn       As marked

Signed: \_\_\_\_\_ Date: \_\_\_\_\_

LEAD TIME WILL START UPON RECEIPT OF SIGNED APPROVAL DRAWING

DISTRIBUTOR'S NAME:		P.O.#
VESTIL MANUFACTURING		X
DRAWN BY: ND	DATE: 10/1/09	W.O.#
REFERENCE: X	SCALE: 1:45	X
QUOTED LEAD TIME: X	QUOTE #	SALES: X
	X	FILE NAME:
		28-007-081