

ADJUSTABLE STEEL GANTRY CRANE - AHS-4-20-12

APPROX WEIGHT: 928.02 lbs.
 DOES NOT INCLUDE WEIGHT OF POWER OR PACKAGING!!!

*** ANY ADDITIONS, DELETIONS, OR OMISSIONS MUST BE CORRECTED ON THIS DRAWING AS THIS DRAWING WILL BE CONSIDERED ALL INCLUSIVE ***

ALL GRAPHICS PROVIDED ARE FOR REFERENCE ONLY. IF CERTAIN DIMENSIONS ARE CRITICAL PLEASE VERIFY THOSE DIMENSIONS WITH YOUR SALESPERSON

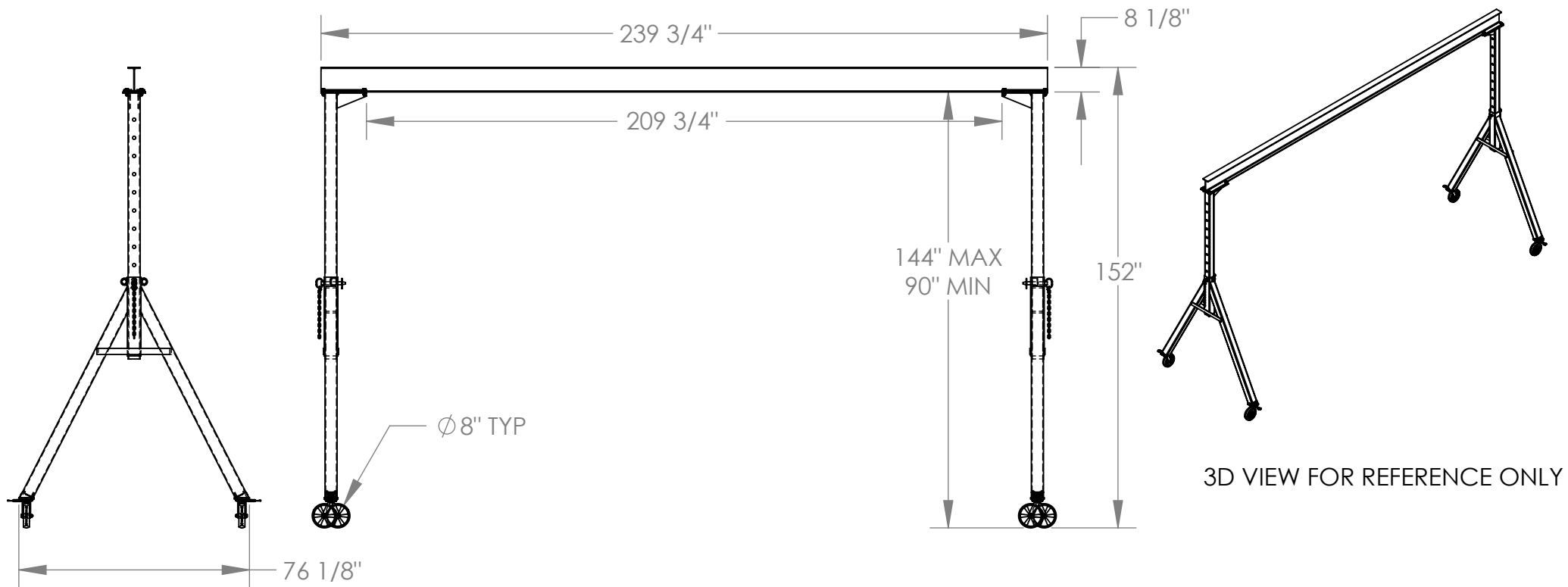

STANDARD FEATURES

MODEL NUMBER IS AHS-4-20-12
 CAPACITY IS 4,000 LBS.
 BASE WIDTH IS 76 1/8"
 OVERALL HEIGHT IS 152"
 OVERALL I-BEAM LENGTH IS 239 3/4"
 USABLE I-BEAM LENGTH IS 209 3/4"
 ADJUSTABLE UNDER I-BEAM HEIGHT
 90" MIN. TO 144" MAX.
 I-BEAM HEIGHT IS 8 1/8"
 CASTERS: (4) 8" X 2" SWIVEL WITH
 FOUR LOCKING POSITION

ADDITIONAL OPTIONS

MANUAL TROLLIES		
1,000 # CAPACITY	2,000 # CAPACITY	4,000 # CAPACITY
QIT-1	QIT-2	QIT-4
E-MT-1	E-MT-2	E-MT-4
E-MT-1-C	E-MT-2-C	E-MT-4-C

**CAPACITY OF ATTACHMENTS MAY
 DERATE CAPACITY OF GANTRY CRANE

I, THE UNDERSIGNED, AGREE THAT THE PRODUCT AS REPRESENTED SATISFIES DESIGN AND DIMENSION REQUIREMENTS. I ALSO ACKNOWLEDGE MY DUTY TO CONFIRM PRODUCT AND INSTALLATION COMPLIANCE WITH ALL APPLICABLE FEDERAL, STATE AND LOCAL REGULATIONS AND STANDARDS.

ALL SPECIAL UNITS ARE NON-RETURNABLE
 As drawn As marked

Signed: _____ Date: _____

LEAD TIME WILL START UPON RECEIPT OF SIGNED APPROVAL DRAWING

DISTRIBUTOR'S NAME:		P.O.#
VESTIL MANUFACTURING		X
DRAWN BY: ND	DATE: 10/1/09	W.O.#
REFERENCE: X	SCALE: 1:48	X
QUOTED LEAD TIME: X	QUOTE #	FILE NAME:
X	X	28-007-078