

ADJUSTABLE STEEL GANTRY CRANE - AHS-2-15-12

APPROX WEIGHT: 807.23 lbs.
DOES NOT INCLUDE WEIGHT OF POWER OR PACKAGING!!!

*** ANY ADDITIONS, DELETIONS, OR OMISSIONS MUST BE CORRECTED ON THIS DRAWING AS THIS DRAWING WILL BE CONSIDERED ALL INCLUSIVE ***

ALL GRAPHICS PROVIDED ARE FOR REFERENCE ONLY. IF CERTAIN DIMENSIONS ARE CRITICAL PLEASE VERIFY THOSE DIMENSIONS WITH YOUR SALESPERSON

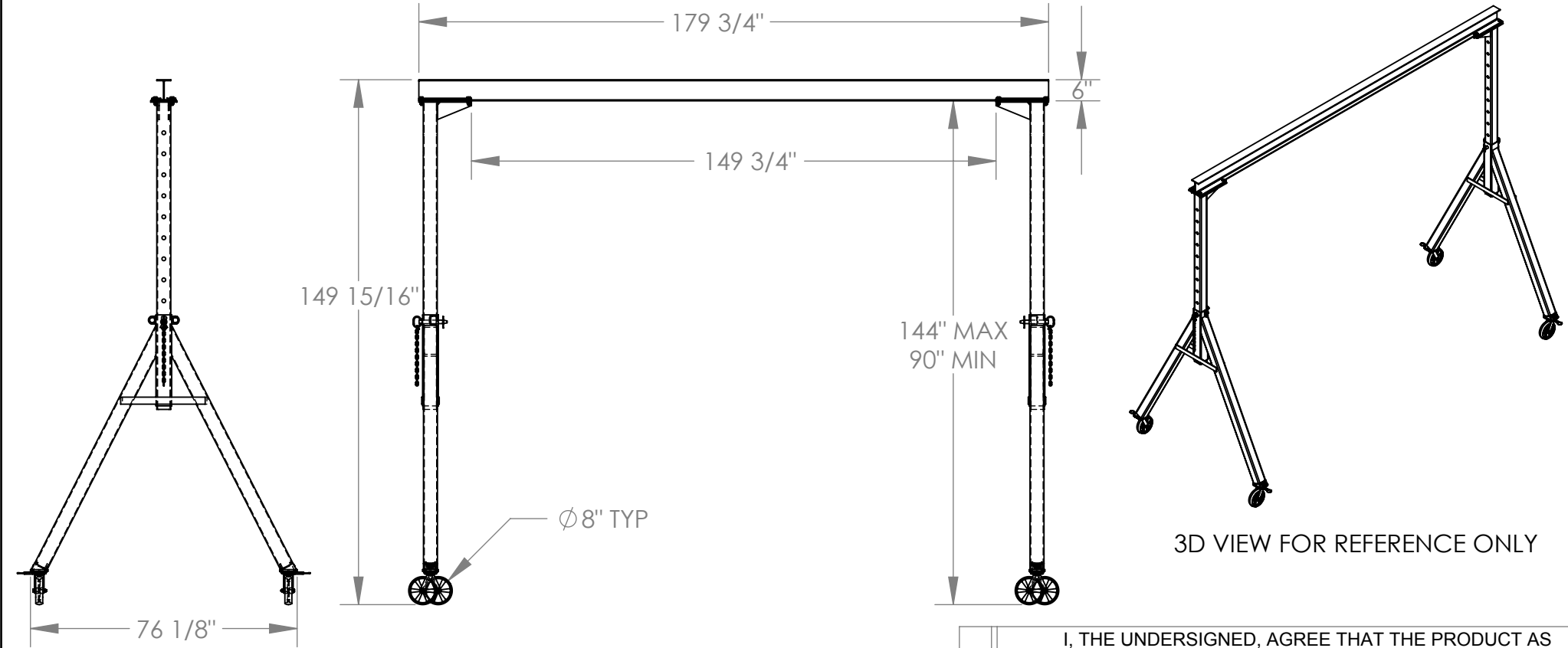

STANDARD FEATURES

MODEL NUMBER IS AHS-2-15-12
CAPACITY IS 2000 LBS.
BASE WIDTH IS 76 1/8"
OVERALL HEIGHT IS 149 15/16"
OVERALL BEAM LENGTH IS 179 3/4"
USABLE BEAM LENGTH IS 149 3/4"
UNDER I-BEAM HEIGHT IS 90" TO 144"
I-BEAM HEIGHT IS 6"
CASTERS: (4) 8" X 2" SWIVEL WITH
FOUR LOCKING POSITION

ADDITIONAL OPTIONS

MANUAL TROLRIES	
1,000 # CAPACITY	2,000 # CAPACITY
QIT-1	QIT-2
E-MT-1	E-MT-2
E-MT-1-C	E-MT-2-C

**CAPACITY OF ATTACHMENTS MAY
DERATE CAPACITY OF GANTRY CRANE

APPROVAL

I, THE UNDERSIGNED, AGREE THAT THE PRODUCT AS REPRESENTED SATISFIES DESIGN AND DIMENSION REQUIREMENTS. I ALSO ACKNOWLEDGE MY DUTY TO CONFIRM PRODUCT AND INSTALLATION COMPLIANCE WITH ALL APPLICABLE FEDERAL, STATE AND LOCAL REGULATIONS AND STANDARDS.
ALL SPECIAL UNITS ARE NON-RETURNABLE
[] As drawn [] As marked

Signed: _____ Date: _____

LEAD TIME WILL START UPON RECEIPT
OF SIGNED APPROVAL DRAWING

DISTRIBUTOR'S NAME:		P.O.#
VESTIL MANUFACTURING		X
DRAWN BY: ND		W.O.#
DATE: 9/30/09		X
REFERENCE: X	SCALE: 1:42	SALES: X
QUOTED LEAD TIME: X	QUOTE #	FILE NAME:
	X	28-007-069