

ADJUSTABLE STEEL GANTRY CRANE - AHS-2-10-14

APPROX WEIGHT: 823.42 lbs.
DOES NOT INCLUDE WEIGHT OF POWER OR PACKAGING!!!

*** ANY ADDITIONS, DELETIONS, OR OMISSIONS MUST BE CORRECTED ON THIS DRAWING AS THIS DRAWING WILL BE CONSIDERED ALL INCLUSIVE ***

ALL GRAPHICS PROVIDED ARE FOR REFERENCE ONLY. IF CERTAIN DIMENSIONS ARE CRITICAL PLEASE VERIFY THOSE DIMENSIONS WITH YOUR SALESPERSON

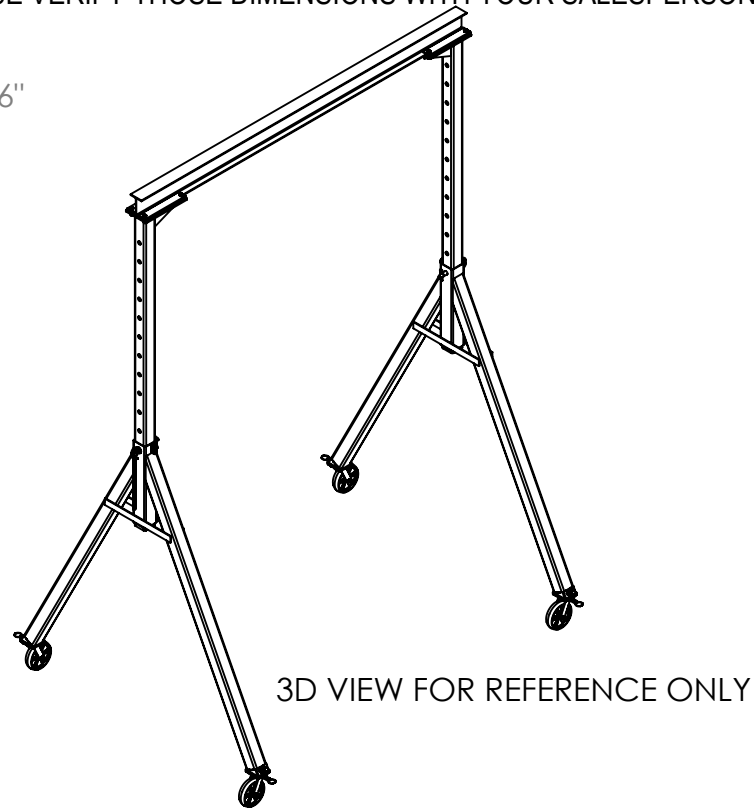
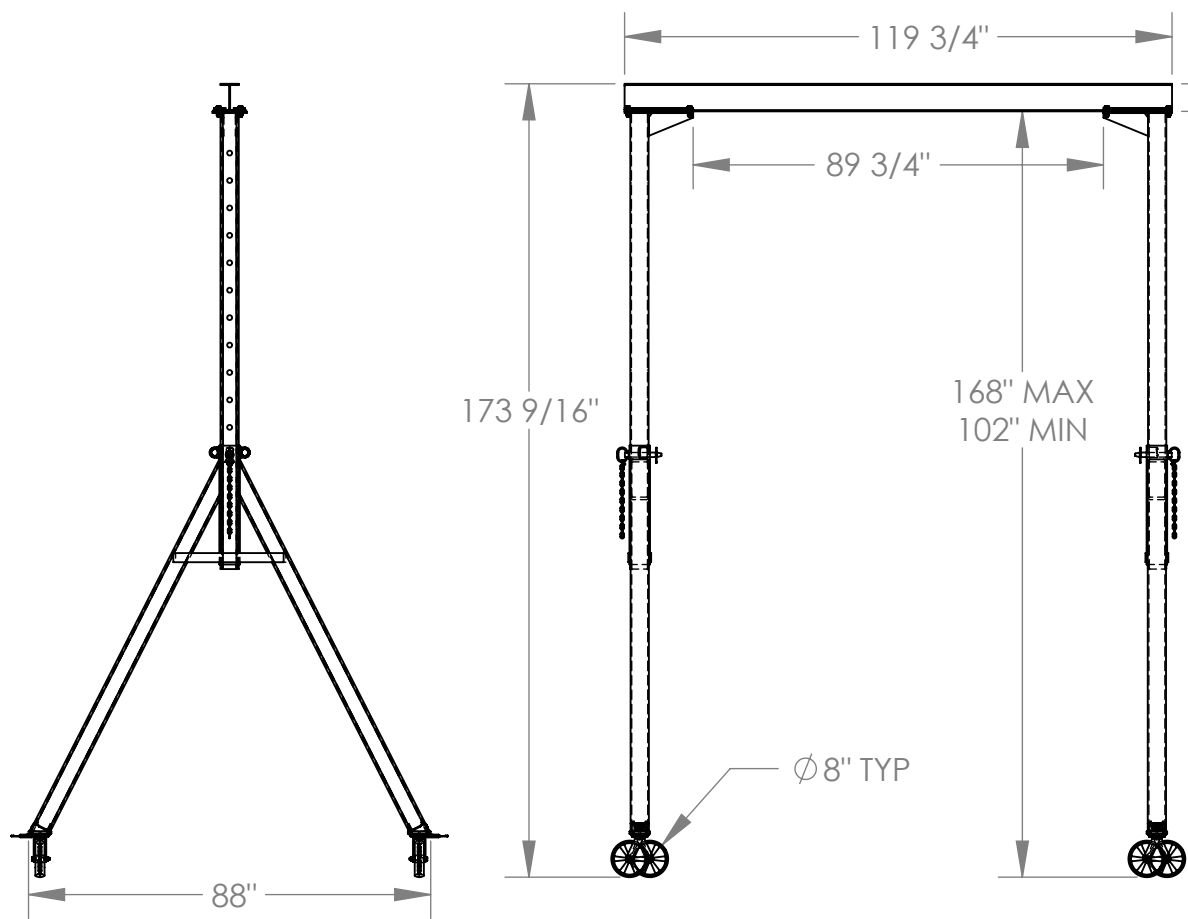

3D VIEW FOR REFERENCE ONLY

STANDARD FEATURES

- MODEL NUMBER IS AHS-2-10-14
- CAPACITY IS 2,000 LBS.
- BASE WIDTH IS 88"
- OVERALL HEIGHT IS 173 9/16"
- OVERALL I-BEAM LENGTH IS 119 3/4"
- USABLE I-BEAM LENGTH IS 89 3/4"
- ADJUSTABLE UNDER I-BEAM
- HEIGHT - 102" MIN. TO 168" MAX.
- I-BEAM HEIGHT IS 6"
- (4) Ø8" SWIVEL CASTERS WITH FOUR LOCKING POSITIONS

ADDITIONAL OPTIONS

| MANUAL TROLRIES | |
|------------------|------------------|
| 1,000 # CAPACITY | 2,000 # CAPACITY |
| QIT-1 | QIT-2 |
| E-MT-1 | E-MT-2 |
| E-MT-1-C | E-MT-2-C |

**CAPACITY OF ATTACHMENTS MAY DERATE CAPACITY OF GANTRY CRANE

APPROVAL

I, THE UNDERSIGNED, AGREE THAT THE PRODUCT AS REPRESENTED SATISFIES DESIGN AND DIMENSION REQUIREMENTS. I ALSO ACKNOWLEDGE MY DUTY TO CONFIRM PRODUCT AND INSTALLATION COMPLIANCE WITH ALL APPLICABLE FEDERAL, STATE AND LOCAL REGULATIONS AND STANDARDS.

ALL SPECIAL UNITS ARE NON-RETURNABLE

[] As drawn [] As marked

Signed: _____ Date: _____

LEAD TIME WILL START UPON RECEIPT OF SIGNED APPROVAL DRAWING

| | | |
|----------------------|-------------|------------|
| DISTRIBUTOR'S NAME: | | P.O.# |
| VESTIL MANUFACTURING | | X |
| DRAWN BY: ND | | W.O.# |
| DATE: 9/30/09 | | X |
| REFERENCE: X | SCALE: 1:42 | SALES: X |
| QUOTED LEAD TIME: X | QUOTE # | FILE NAME: |
| | X | 28-007-068 |