

# ALUMINUM GANTRY CRANE - AHA-4-8-12

APPROX WEIGHT: 233.03 lbs.  
DOES NOT INCLUDE WEIGHT OF POWER OR PACKAGING!!!

\*\*\* ANY ADDITIONS, DELETIONS, OR OMISSIONS MUST BE CORRECTED ON THIS DRAWING AS THIS DRAWING WILL BE CONSIDERED ALL INCLUSIVE \*\*\*

ALL GRAPHICS PROVIDED ARE FOR REFERENCE ONLY. IF CERTAIN DIMENSIONS ARE CRITICAL PLEASE VERIFY THOSE DIMENSIONS WITH YOUR SALESPERSON

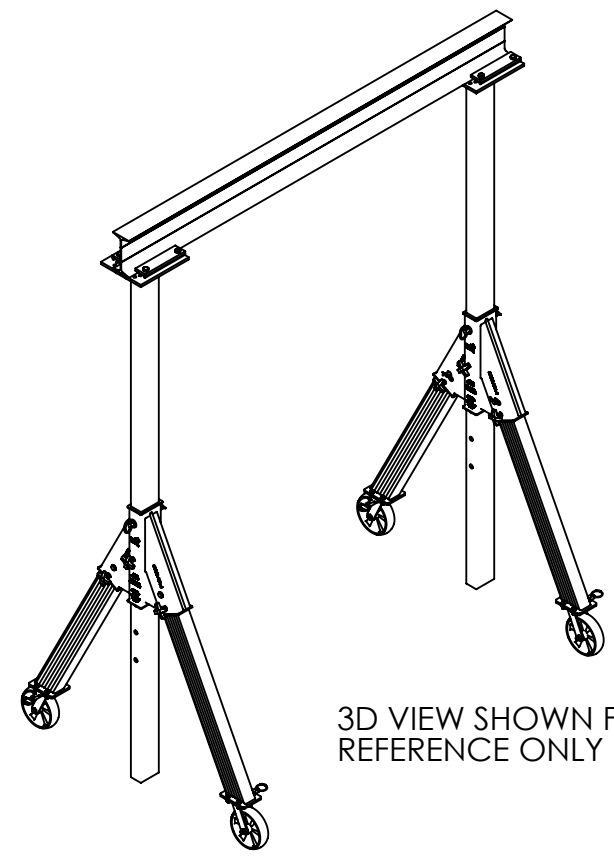
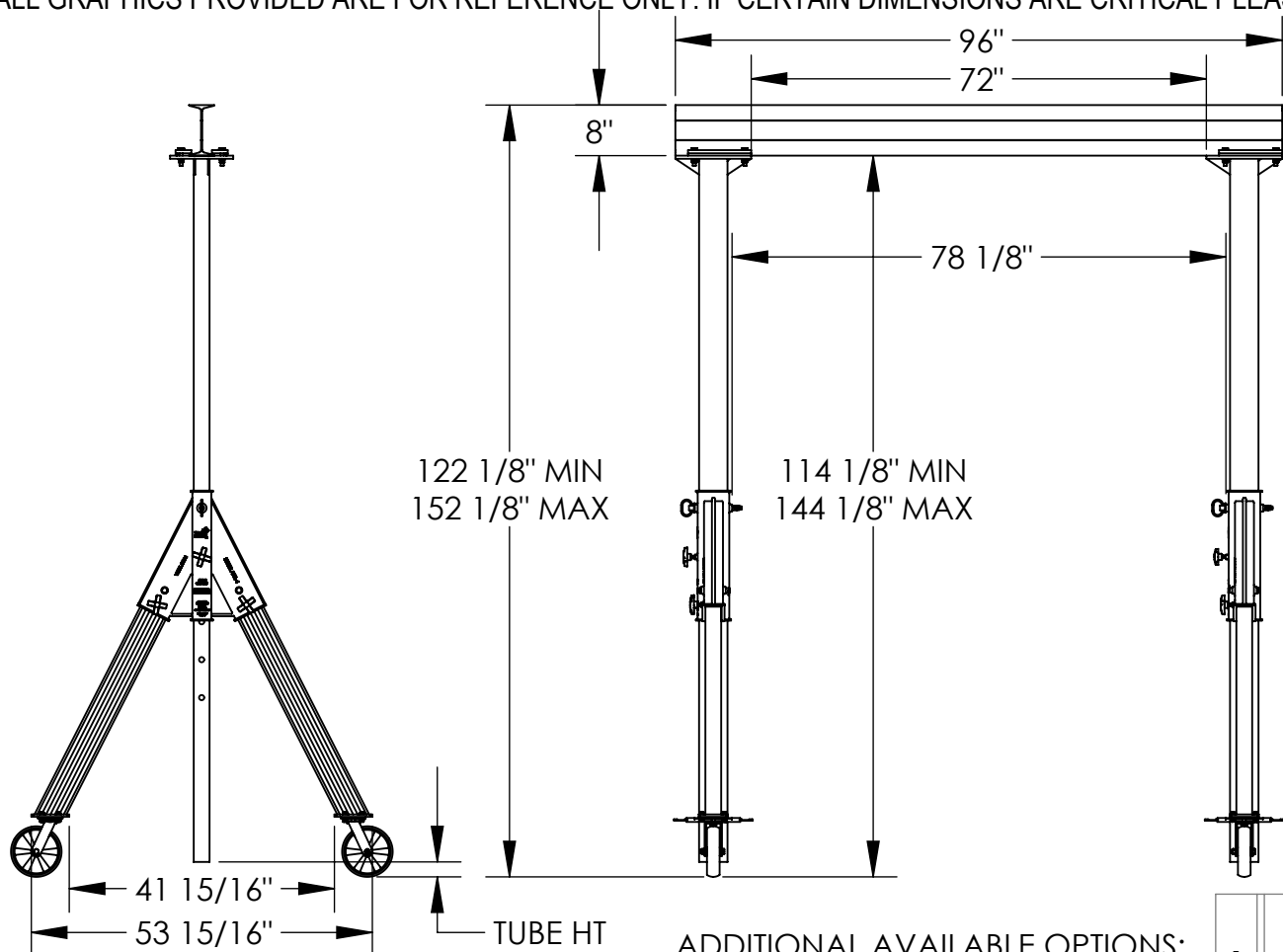

3D VIEW SHOWN FOR REFERENCE ONLY

## STANDARD FEATURES

MODEL NUMBER IS AHA-4-8-12  
CAPACITY IS 4,000 LBS.  
OVERALL BASE WIDTH IS 53 15/16"  
USABLE BASE WIDTH IS 41 15/16"  
OVERALL I-BEAM LENGTH IS 96"  
USABLE I-BEAM LENGTH IS 72"  
I-BEAM HEIGHT IS 8"  
UNDER I-BEAM CLEARANCE IS 114 1/8" TO 144 1/8"  
TUBE HEIGHT IS 2 1/4" MIN., 32 1/4" MAX.  
STRADDLE LENGTH IS 78 1/8"  
Ø8" SWIVEL CASTERS W/4 POSITION LOCK

## SPECIAL FEATURES

NONE

## ADDITIONAL AVAILABLE OPTIONS:

MANUAL TROLLIES		
1,000# CAPACITY	2,000# CAPACITY	4,000# CAPACITY
QIT-1	QIT-2	QIT-4
E-MT-1	E-MT-2	E-MT-2
E-MT-1-C	E-MT-2-C	E-MT-4-C

\*\*CAPACITY OF ATTACHMENTS MAY DERATE CAPACITY OF GANTRY CRANE

APPROVAL

I, THE UNDERSIGNED, AGREE THAT THE PRODUCT AS REPRESENTED SATISFIES DESIGN AND DIMENSION REQUIREMENTS. I ALSO ACKNOWLEDGE MY DUTY TO CONFIRM PRODUCT AND INSTALLATION COMPLIANCE WITH ALL APPLICABLE FEDERAL, STATE AND LOCAL REGULATIONS AND STANDARDS.  
**ALL SPECIAL UNITS ARE NON-RETURNABLE**  
[ ] As drawn [ ] As marked

Signed: \_\_\_\_\_ Date: \_\_\_\_\_

LEAD TIME WILL START UPON RECEIPT OF SIGNED APPROVAL DRAWING

DISTRIBUTOR'S NAME:		P.O.#
VESTIL MANUFACTURING		X
DRAWN BY: ND		W.O.#
DATE: 3/25/11		X
REFERENCE: X	SCALE: 1:30	SALES: X
QUOTED LEAD TIME: X	QUOTE # X	FILE NAME:
		28-007-221