

ALUMINUM GANTRY CRANE - AHA-4-12-12

APPROX WEIGHT: 281.38 lbs.
DOES NOT INCLUDE WEIGHT OF POWER OR PACKAGING!!!

*** ANY ADDITIONS, DELETIONS, OR OMISSIONS MUST BE CORRECTED ON THIS DRAWING AS THIS DRAWING WILL BE CONSIDERED ALL INCLUSIVE ***
ALL GRAPHICS PROVIDED ARE FOR REFERENCE ONLY. IF CERTAIN DIMENSIONS ARE CRITICAL PLEASE VERIFY THOSE DIMENSIONS WITH YOUR SALESPERSON

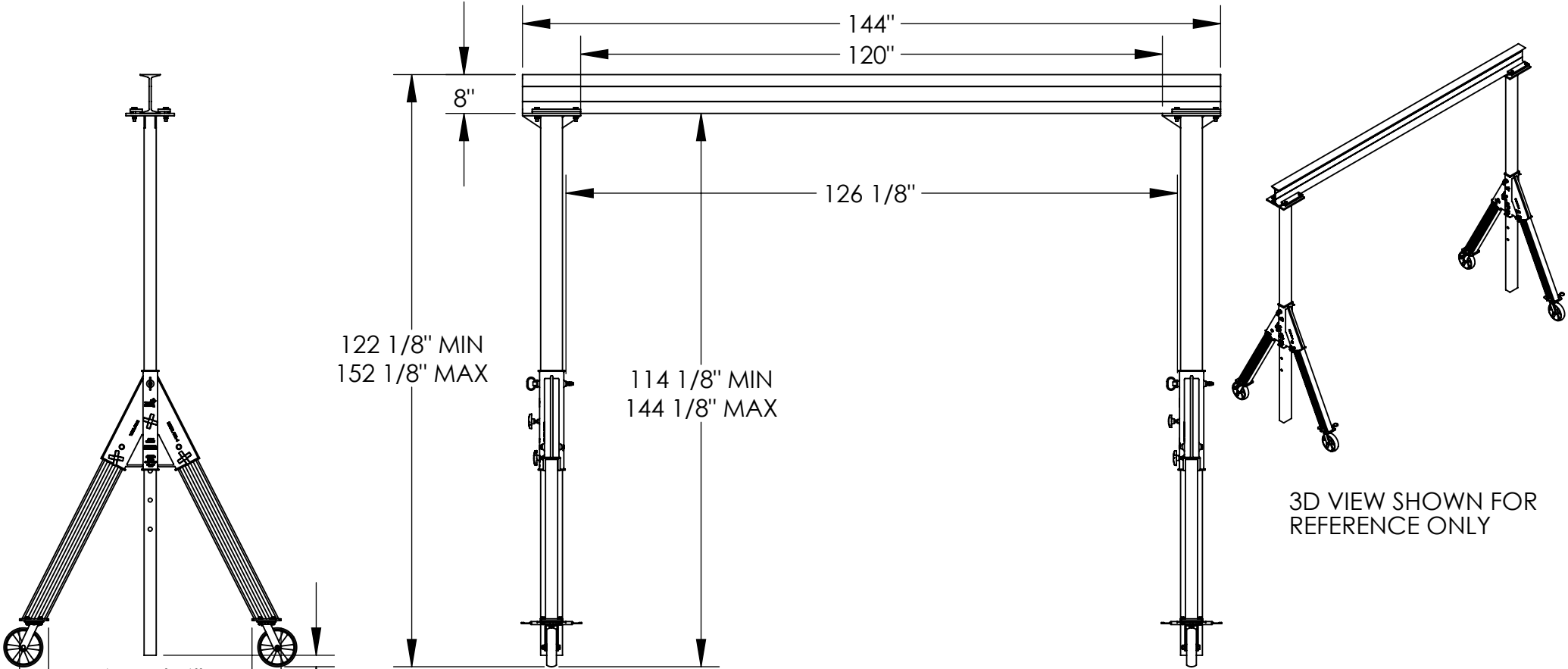

STANDARD FEATURES

MODEL NUMBER IS AHA-4-12-12
CAPACITY IS 4,000 LBS.
OVERALL BASE WIDTH IS 53 15/16"
USABLE BASE WIDTH IS 41 15/16"
OVERALL I-BEAM LENGTH IS 144"
USABLE I-BEAM LENGTH IS 120"
I-BEAM HEIGHT IS 8"
UNDER I-BEAM CLEARANCE IS 114 1/8" TO 144-1/8"
TUBE HEIGHT IS 2 1/4" MIN., 32 1/4" MAX.
STRADDLE LENGTH IS 126 1/8"
Ø8" SWIVEL CASTERS W/4 POSITION LOCK

SPECIAL FEATURES

NONE

ADDITIONAL AVAILABLE OPTIONS:

MANUAL TROLLIES		
1,000# CAPACITY	2,000# CAPACITY	4,000# CAPACITY
QIT-1	QIT-2	QIT-4
E-MT-1	E-MT-2	E-MT-2
E-MT-1-C	E-MT-2-C	E-MT-4-C

**CAPACITY OF ATTACHMENTS
MAY DERATE CAPACITY OF
GANTRY CRANE

A P P R O V A L

I, THE UNDERSIGNED, AGREE THAT THE PRODUCT AS REPRESENTED SATISFIES DESIGN AND DIMENSION REQUIREMENTS. I ALSO ACKNOWLEDGE MY DUTY TO CONFIRM PRODUCT AND INSTALLATION COMPLIANCE WITH ALL APPLICABLE FEDERAL, STATE AND LOCAL REGULATIONS AND STANDARDS.
ALL SPECIAL UNITS ARE NON-RETURNABLE
[] As drawn [] As marked

Signed: _____ Date: _____

LEAD TIME WILL START UPON RECEIPT OF SIGNED APPROVAL DRAWING

DISTRIBUTOR'S NAME:		P.O.#
VESTIL MANUFACTURING		X
DRAWN BY: ND		W.O.#
DATE: 3/25/11		X
REFERENCE: X	SCALE: 1:30	SALES: X
QUOTED LEAD TIME: X	QUOTE #	FILE NAME:
	X	28-007-225