

ADJUSTABLE ALUMINUM GANTRY CRANE - AHA-2-12-12

APPROX WEIGHT: 220.78 lbs.
DOES NOT INCLUDE WEIGHT OF POWER OR PACKAGING!!!

*** ANY ADDITIONS, DELETIONS, OR OMISSIONS MUST BE CORRECTED ON THIS DRAWING AS THIS DRAWING WILL BE CONSIDERED ALL INCLUSIVE ***

ALL GRAPHICS PROVIDED ARE FOR REFERENCE ONLY. IF CERTAIN DIMENSIONS ARE CRITICAL PLEASE VERIFY THOSE DIMENSIONS WITH YOUR SALESPERSON

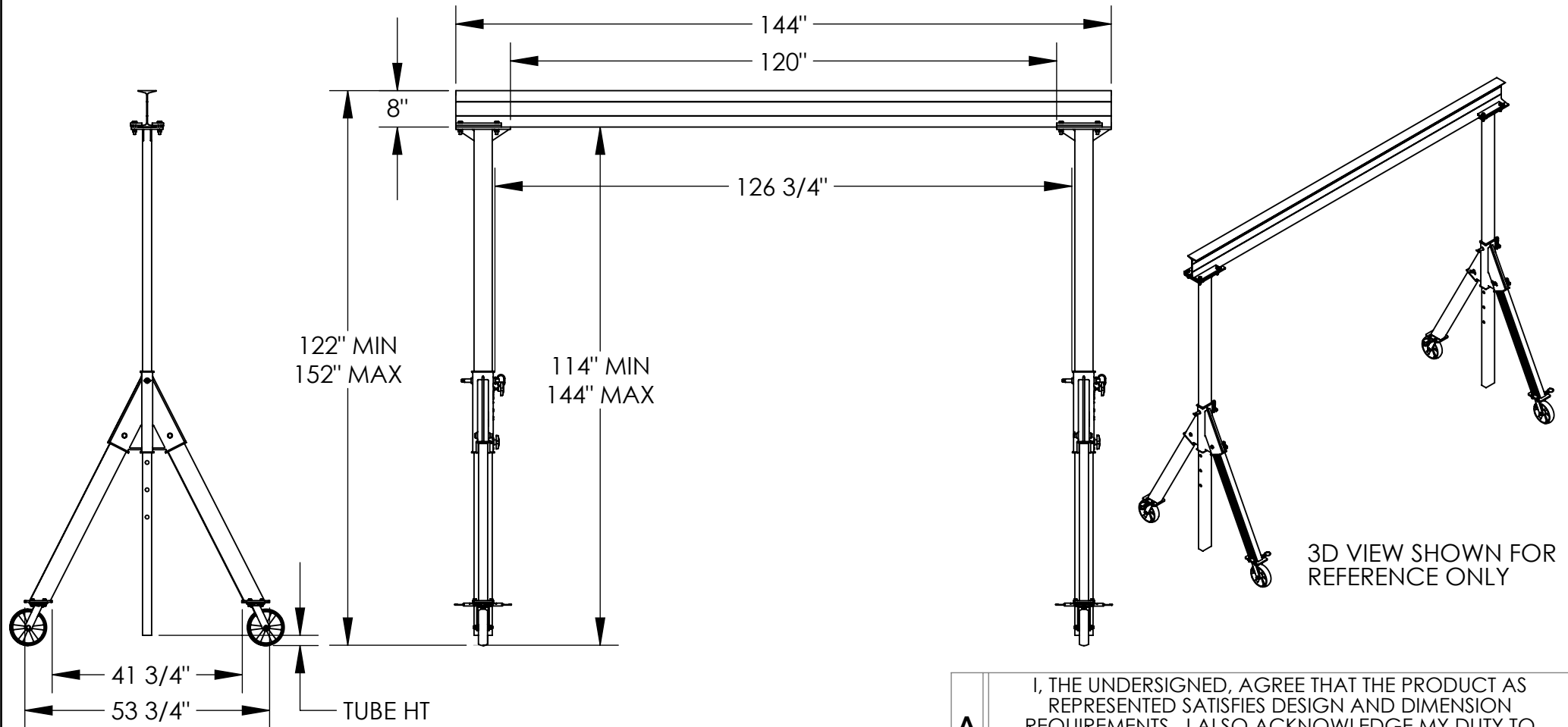

3D VIEW SHOWN FOR REFERENCE ONLY

STANDARD FEATURES

- MODEL NUMBER IS AHA-2-12-12
- CAPACITY IS 2,000 LBS.
- OVERALL BASE WIDTH IS 53 3/4"
- USABLE BASE WIDTH IS 41 3/4"
- OVERALL BEAM LENGTH IS 144"
- USABLE BEAM LENGTH IS 120"
- OVERALL I-BEAM HEIGHT IS 8"
- UNDER I-BEAM TO GROUND:
114" MIN., 144" MAX.
- TUBE HEIGHT: 2 1/4" MIN., 32 1/4" MAX.
- STRADDLE LENGTH IS 126 3/4"
- Ø8" SWIVEL CASTERS W/4 POSITION LOCK

CAPACITY OF ATTACHMENTS MAY DERATE CAPACITY OF GANTRY CRANE

SPECIAL FEATURES

NONE

ADDITIONAL AVAILABLE OPTIONS:

MANUAL TROLRIES	
1,000 # CAPACITY	2,000 # CAPACITY
QIT-1	QIT-2
E-MT-1	E-MT-2
E-MT-1-C	E-MT-2-C

APPROVAL

I, THE UNDERSIGNED, AGREE THAT THE PRODUCT AS REPRESENTED SATISFIES DESIGN AND DIMENSION REQUIREMENTS. I ALSO ACKNOWLEDGE MY DUTY TO CONFIRM PRODUCT AND INSTALLATION COMPLIANCE WITH ALL APPLICABLE FEDERAL, STATE AND LOCAL REGULATIONS AND STANDARDS.
ALL SPECIAL UNITS ARE NON-RETURNABLE
[] As drawn [] As marked

Signed: _____ Date: _____

LEAD TIME WILL START UPON RECEIPT OF SIGNED APPROVAL DRAWING

DISTRIBUTOR'S NAME:		P.O.#
VESTIL MANUFACTURING		X
DRAWN BY: ND		W.O.#
DATE: 1/8/08		X
REFERENCE: X	SCALE: 1:32	SALES: X
QUOTED LEAD TIME: X	QUOTE #	FILE NAME:
	X	28-007-099