

# ADJUSTABLE ALUMINUM GANTRY CRANE - AHA-2-10-8

APPROX WEIGHT: 178.54 lbs.  
DOES NOT INCLUDE WEIGHT OF POWER OR PACKAGING!!!

\*\*\* ANY ADDITIONS, DELETIONS, OR OMISSIONS MUST BE CORRECTED ON THIS DRAWING AS THIS DRAWING WILL BE CONSIDERED ALL INCLUSIVE \*\*\*

ALL GRAPHICS PROVIDED ARE FOR REFERENCE ONLY. IF CERTAIN DIMENSIONS ARE CRITICAL PLEASE VERIFY THOSE DIMENSIONS WITH YOUR SALESPERSON

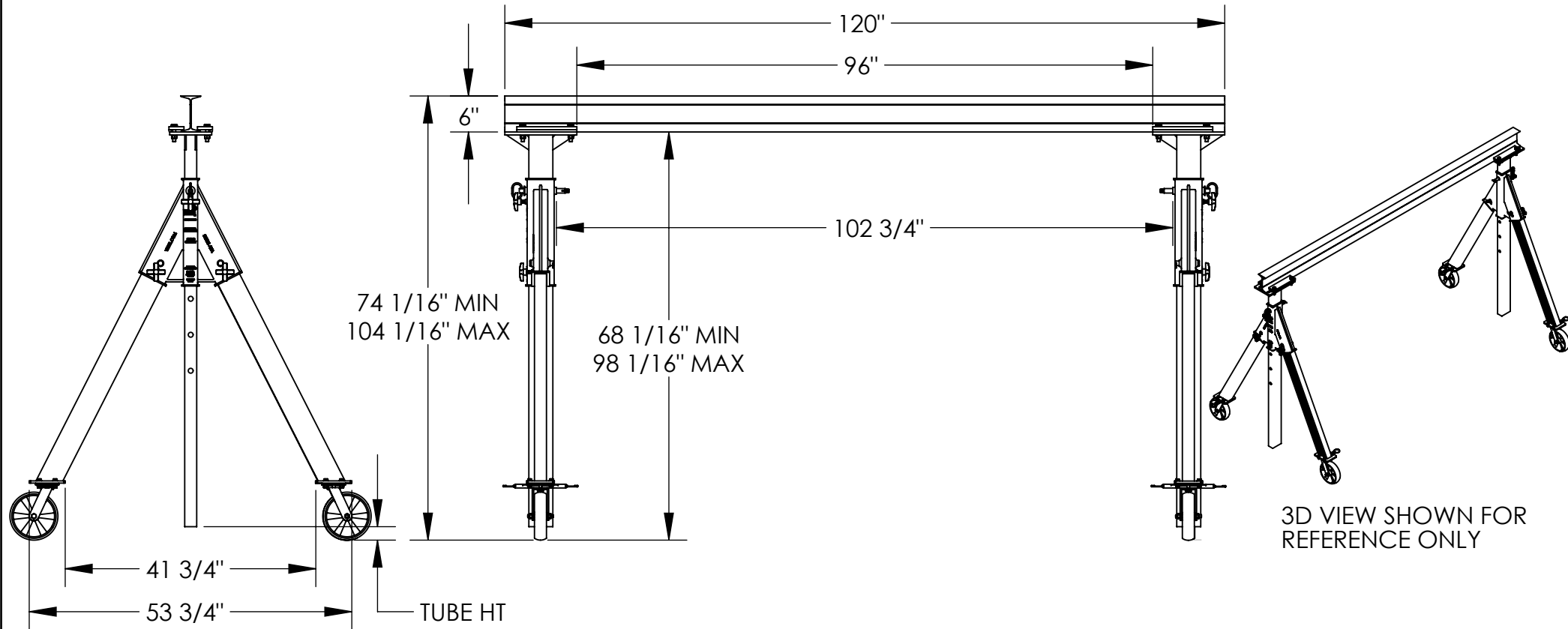

## STANDARD FEATURES

- MODEL NUMBER IS AHA-2-10-8
- CAPACITY IS 2,000 LBS.
- OVERALL BASE WIDTH IS 53 3/4"
- USABLE BASE WIDTH IS 41 3/4"
- OVERALL BEAM LENGTH IS 120"
- USABLE BEAM LENGTH IS 96"
- I-BEAM HEIGHT IS 6"
- UNDER I-BEAM TO GROUND:  
68" MIN., 98" MAX.
- TUBE HEIGHT: 2 1/4" MIN., 32 1/4" MAX.
- STRADDLE LENGTH IS 102 3/4"
- Ø8" SWIVEL CASTERS W/4 POSITION LOCK

\*CAPACITY OF ATTACHMENTS MAY DERATE CAPACITY OF GANTRY CRANE\*

## SPECIAL FEATURES

NONE

ADDITIONAL AVAILABLE OPTIONS:

MANUAL TROLRIES	
1,000 # CAPACITY	2,000 # CAPACITY
QIT-1	QIT-2
E-MT-1	E-MT-2
E-MT-1-C	E-MT-2-C

**APPROVAL**

I, THE UNDERSIGNED, AGREE THAT THE PRODUCT AS REPRESENTED SATISFIES DESIGN AND DIMENSION REQUIREMENTS. I ALSO ACKNOWLEDGE MY DUTY TO CONFIRM PRODUCT AND INSTALLATION COMPLIANCE WITH ALL APPLICABLE FEDERAL, STATE AND LOCAL REGULATIONS AND STANDARDS.

**ALL SPECIAL UNITS ARE NON-RETURNABLE**  
 As drawn     As marked

Signed: \_\_\_\_\_ Date: \_\_\_\_\_

LEAD TIME WILL START UPON RECEIPT OF SIGNED APPROVAL DRAWING

DISTRIBUTOR'S NAME: VESTIL MANUFACTURING

P.O.# X

W.O.# X

SALES: X

FILE NAME: 28-007-188

DRAWN BY: ND    DATE: 1/31/11

REFERENCE: X    SCALE: 1:24

QUOTED LEAD TIME: X    QUOTE # X