

# ADJUSTABLE ALUMINUM GANTRY CRANE - AHA-15-8-8-PNU APPROX WEIGHT: 226.55 lbs. DOES NOT INCLUDE WEIGHT OF POWER OR PACKAGING!!!

\*\*\* ANY ADDITIONS, DELETIONS, OR OMISSIONS MUST BE CORRECTED ON THIS DRAWING AS THIS DRAWING WILL BE CONSIDERED ALL INCLUSIVE \*\*\*  
 ALL GRAPHICS PROVIDED ARE FOR REFERENCE ONLY. IF CERTAIN DIMENSIONS ARE CRITICAL PLEASE VERIFY THOSE DIMENSIONS WITH YOUR SALESPERSON

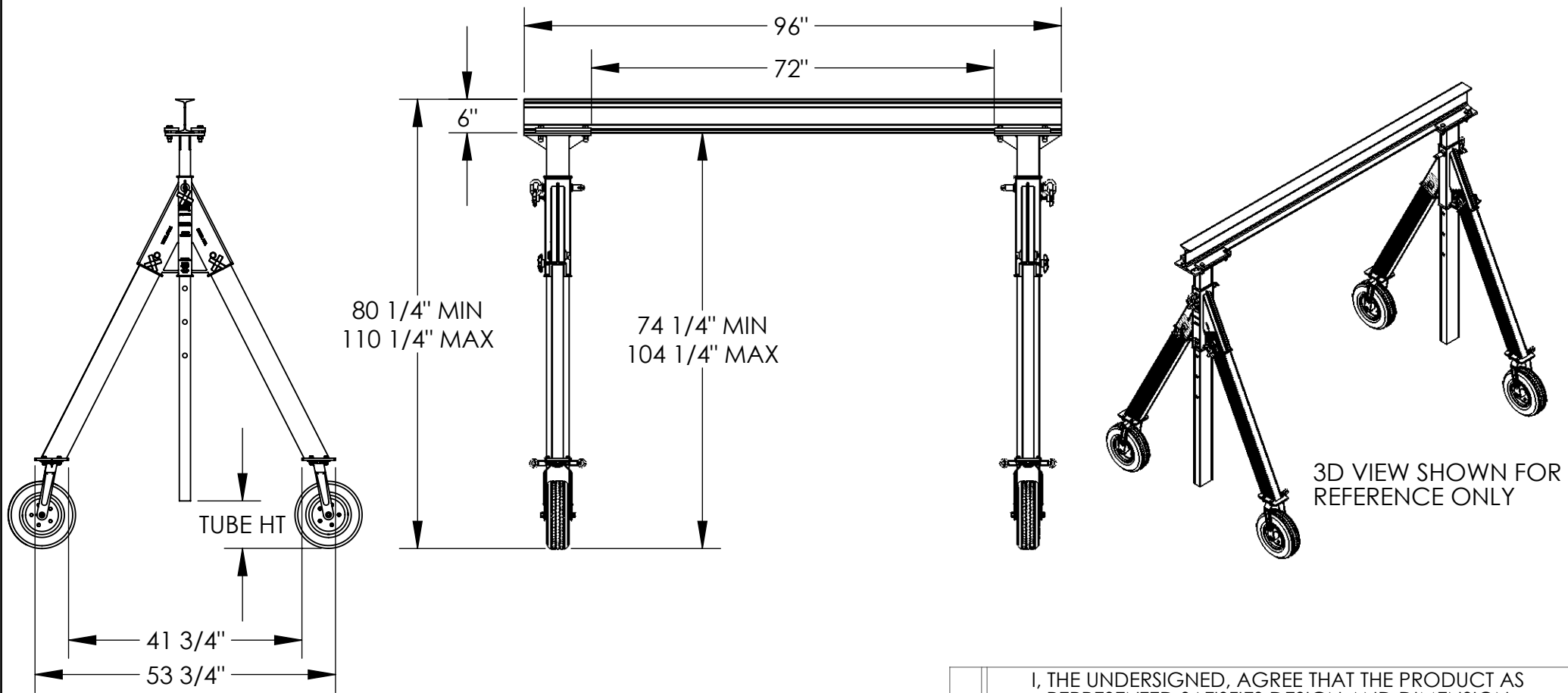

## STANDARD FEATURES

MODEL NUMBER IS AHA-15-8-8-PNU  
 CAPACITY IS 1,500 LBS.  
 OVERALL BASE WIDTH IS 53 3/4"  
 USABLE BASE WIDTH IS 41 3/4"  
 OVERALL I-BEAM LENGTH IS 96"  
 USABLE I-BEAM LENGTH IS 72"  
 UNDER I-BEAM TO GROUND:  
 74 1/4" MIN., 104 1/4" MAX.  
 TUBE HEIGHT: 8 1/2" MIN., 38 1/2" MAX.  
 I-BEAM HEIGHT IS 6"  
 CASTERS: (4) Ø12" PNEUMATIC SWIVEL  
 W/ FOUR POSITION LOCK

## SPECIAL FEATURES

NONE

ADDITIONAL OPTIONS:

MANUAL TROLRIES
1,000 # CAPACITY
QIT-1
E-MT-1
E-MT-1-C

APPROVAL

I, THE UNDERSIGNED, AGREE THAT THE PRODUCT AS REPRESENTED SATISFIES DESIGN AND DIMENSION REQUIREMENTS. I ALSO ACKNOWLEDGE MY DUTY TO CONFIRM PRODUCT AND INSTALLATION COMPLIANCE WITH ALL APPLICABLE FEDERAL, STATE AND LOCAL REGULATIONS AND STANDARDS.  
**ALL SPECIAL UNITS ARE NON-RETURNABLE**  
 As drawn       As marked

Signed: \_\_\_\_\_ Date: \_\_\_\_\_

LEAD TIME WILL START UPON RECEIPT OF SIGNED APPROVAL DRAWING

DISTRIBUTOR'S NAME:		P.O.#
VESTIL MANUFACTURING		X
DRAWN BY: ND	DATE: 7/11/13	W.O.#
REFERENCE: X	SCALE: 1:26	X
QUOTED LEAD TIME: X	QUOTE #	FILE NAME:
	X	28-007-285

\*CAPACITY OF ATTACHMENTS MAY DERATE CAPACITY OF GANTRY CRANE\*