

ADJUSTABLE ALUMINUM GANTRY CRANE - AHA-15-8-12-PNU

APPROX WEIGHT: 246.67 lbs.
DOES NOT INCLUDE WEIGHT OF POWER OR PACKAGING!!!

*** ANY ADDITIONS, DELETIONS, OR OMISSIONS MUST BE CORRECTED ON THIS DRAWING AS THIS DRAWING WILL BE CONSIDERED ALL INCLUSIVE ***
ALL GRAPHICS PROVIDED ARE FOR REFERENCE ONLY. IF CERTAIN DIMENSIONS ARE CRITICAL PLEASE VERIFY THOSE DIMENSIONS WITH YOUR SALESPERSON

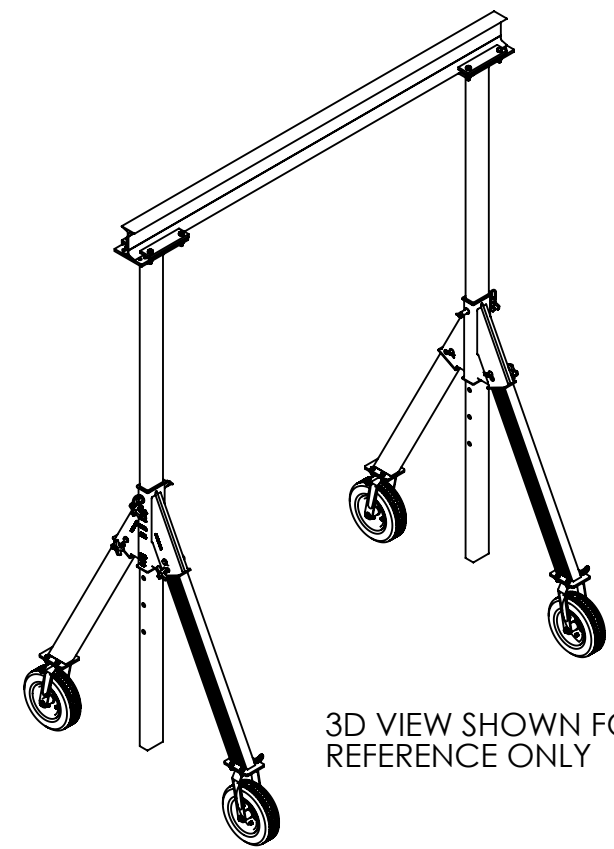
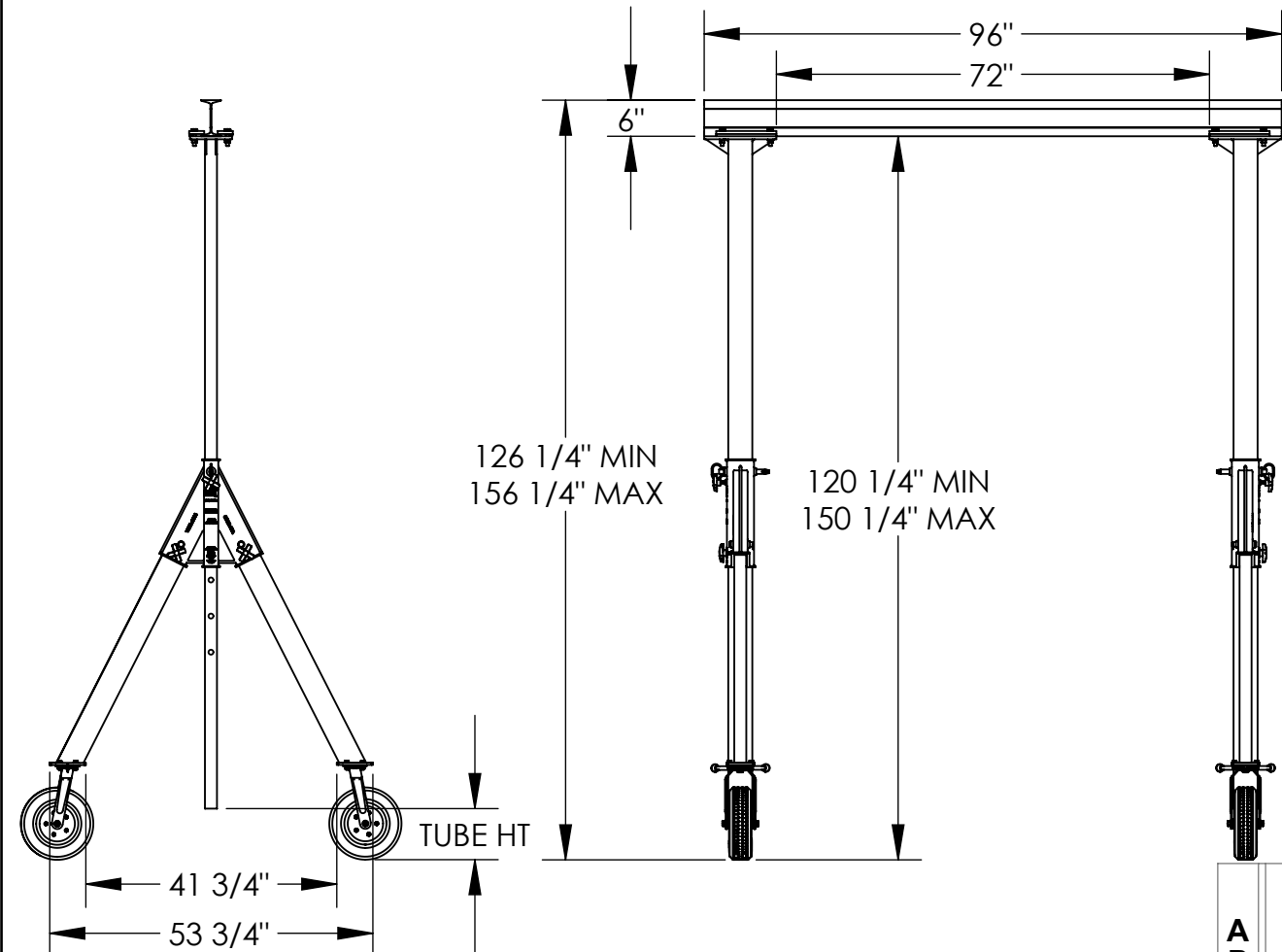

3D VIEW SHOWN FOR REFERENCE ONLY

STANDARD FEATURES

- MODEL NUMBER IS AHA-15-8-12-PNU
- CAPACITY IS 1,500 LBS.
- OVERALL BASE WIDTH IS 53 3/4"
- USABLE BASE WIDTH IS 41 3/4"
- OVERALL I-BEAM LENGTH IS 96"
- USABLE I-BEAM LENGTH IS 72"
- UNDER I-BEAM TO GROUND:
120 1/4" MIN., 150 1/4" MAX.
- TUBE HEIGHT: 8 1/2" MIN., 38 1/2" MAX.
- I-BEAM HEIGHT IS 6"
- CASTERS: (4) Ø12" PNEUMATIC SWIVEL
W/ FOUR POSITION LOCK

*CAPACITY OF ATTACHMENTS MAY
DERATE CAPACITY OF GANTRY CRANE*

SPECIAL FEATURES

NONE

AVAILABLE OPTIONS:

MANUAL TROLLEYS
1,000 # CAPACITY
QIT-1
E-MT-1
E-MT-1-C

APPROVAL

I, THE UNDERSIGNED, AGREE THAT THE PRODUCT AS REPRESENTED SATISFIES DESIGN AND DIMENSION REQUIREMENTS. I ALSO ACKNOWLEDGE MY DUTY TO CONFIRM PRODUCT AND INSTALLATION COMPLIANCE WITH ALL APPLICABLE FEDERAL, STATE AND LOCAL REGULATIONS AND STANDARDS.
ALL SPECIAL UNITS ARE NON-RETURNABLE
[] As drawn [] As marked

Signed: _____ Date: _____

LEAD TIME WILL START UPON RECEIPT OF SIGNED APPROVAL DRAWING

DISTRIBUTOR'S NAME:		P.O.#
VESTIL MANUFACTURING		X
DRAWN BY: ND		W.O.#
DATE: 7/11/13		X
REFERENCE: X	SCALE: 1:31	SALES: X
QUOTED LEAD TIME: X	QUOTE # X	FILE NAME:
		28-007-287