

ADJUSTABLE ALUMINUM GANTRY CRANE - AHA-15-10-8-PNU

APPROX WEIGHT: 233.68 lbs.
 DOES NOT INCLUDE WEIGHT OF POWER OR PACKAGING!!!

*** ANY ADDITIONS, DELETIONS, OR OMISSIONS MUST BE CORRECTED ON THIS DRAWING AS THIS DRAWING WILL BE CONSIDERED ALL INCLUSIVE ***
 ALL GRAPHICS PROVIDED ARE FOR REFERENCE ONLY. IF CERTAIN DIMENSIONS ARE CRITICAL PLEASE VERIFY THOSE DIMENSIONS WITH YOUR SALESPERSON

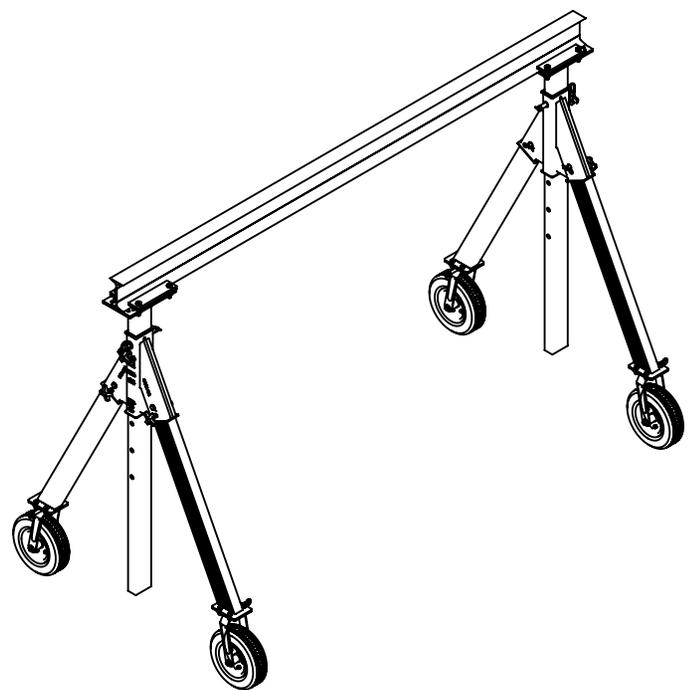
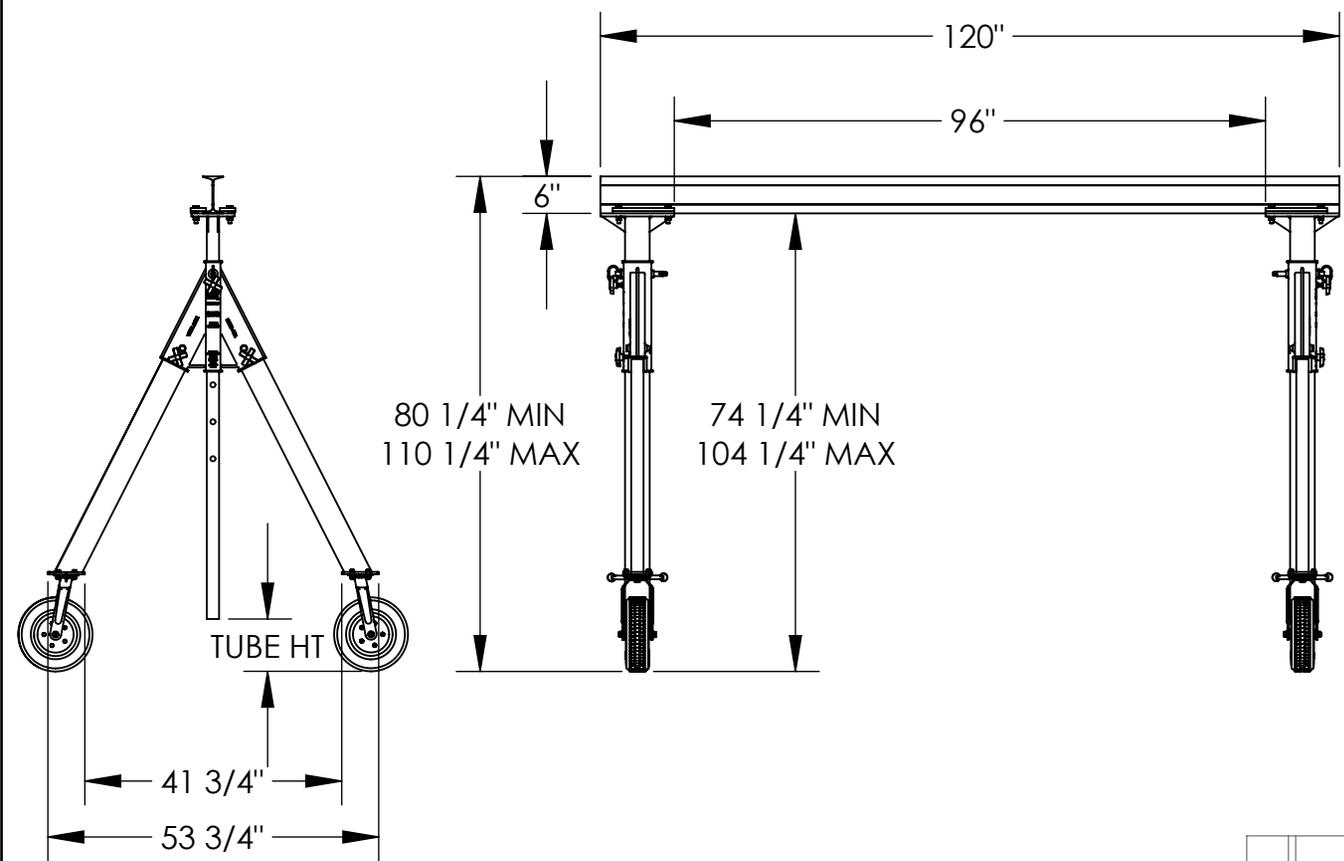

3D VIEW SHOWN FOR REFERENCE ONLY

STANDARD FEATURES

- MODEL NUMBER IS AHA-15-10-8-PNU
- CAPACITY IS 1,500 LBS.
- OVERALL BASE WIDTH IS 53 3/4"
- USABLE BASE WIDTH IS 41 3/4"
- OVERALL I-BEAM LENGTH IS 120"
- USABLE I-BEAM LENGTH IS 96"
- UNDER I-BEAM TO GROUND:
 74 1/4" MIN., 104 1/4" MAX.
- TUBE HEIGHT: 8 1/2" MIN., 38 1/2" MAX.
- I-BEAM HEIGHT IS 6"
- CASTERS: (4) Ø12" PNEUMATIC SWIVEL
 W/ FOUR POSITION LOCK

SPECIAL FEATURES

NONE

ADDITIONAL OPTIONS:

MANUAL TROLRIES
1,000 # CAPACITY
QIT-1
E-MT-1
E-MT-1-C

CAPACITY OF ATTACHMENTS MAY DERATE CAPACITY OF GANTRY CRANE

A P P R O V A L

I, THE UNDERSIGNED, AGREE THAT THE PRODUCT AS REPRESENTED SATISFIES DESIGN AND DIMENSION REQUIREMENTS. I ALSO ACKNOWLEDGE MY DUTY TO CONFIRM PRODUCT AND INSTALLATION COMPLIANCE WITH ALL APPLICABLE FEDERAL, STATE AND LOCAL REGULATIONS AND STANDARDS.

ALL SPECIAL UNITS ARE NON-RETURNABLE
 As drawn As marked

Signed: _____ Date: _____

LEAD TIME WILL START UPON RECEIPT OF SIGNED APPROVAL DRAWING

DISTRIBUTOR'S NAME:		P.O.#
VESTIL MANUFACTURING		X
DRAWN BY: ND		W.O.#
DATE: 7/11/13		X
REFERENCE: X	SCALE: 1:31	SALES: X
QUOTED LEAD TIME: X	QUOTE #	FILE NAME:
	X	28-007-288