

OPERATION, SERVICE & PARTS MANUAL



BUDGIT[®] **MAN & GUARD[®]** **electric hoists**

FOREWORD

This book contains important information to help you install, operate, maintain and service your new Electric Hoist. We recommend that you study its content thoroughly before putting your hoist into use. Then, thru proper installation, application of correct operating procedures, and by practicing the recommended maintenance suggestions you will be assured maximum lifting service from the hoist.

Complete inspection, maintenance and overhaul service is available for Budgit Electric Hoists at Authorized Repair Stations. All are staffed by qualified factory-trained service men; have authorized testing equipment; and stock a complete inventory of factory approved Budgit replacement parts.

Complete replacement parts information is given in Section IX. It will likely be a long time before parts information is needed, therefore, after you completely familiarized yourself with operation and preventive maintenance procedures, we suggest that this instruction and parts manual be carefully filed for future reference.

Notice: Use only factory approved Budgit replacement parts, available from Authorized Repair Stations or Budgit Hoist Distributors.

The "Accident Prevention Manual for Industrial Operations' (8th Edition) by the National Safety Council states:

"Employees who work near cranes or assist in hooking on or arranging loads should be instructed to keep out from under loads. Supervisors should watch closely to see that this rule is strictly followed.

From safety standpoint, one factor is paramount: conduct all lifting operations in such a manner that if there were an equipment failure, no personnel would be injured. This means keep out from under raised loads!"

THE INFORMATION CONTAINED IN THIS MANUAL IS FOR INFORMATIONAL PURPOSES ONLY AND BUDGIT HOISTS DOES NOT WARRANT OR OTHERWISE GUARANTEE (IMPLIEDLY OR EXPRESSLY) ANYTHING OTHER THAN THE COMPONENTS THAT BUDGIT MANUFACTURES AND ASSUMES NO LEGAL RESPONSIBILITY (INCLUDING, BUT NOT LIMITED TO CONSEQUENTIAL DAMAGES) FOR INFORMATION CONTAINED IN THIS MANUAL.

INDEX

SECTION I	GENERAL DESCRIPTION	Page
Paragraph	1 -1 General	3
Paragraph	1 -2 Hoist Service Classification	3
Paragraph	1-3 Basic Construction	3
Paragraph	1 -4 Differences Between Models and Sizes	4
Paragraph	1-5 MAN-GUARD Overload Clutch	4
SECTION II	INSTALLATION	
Paragraph	2-1 General	4
Paragraph	2-2 Installation	4
Paragraph	2-3 Pre-Installation Checks	5
Paragraph	2-4 Connecting Hoist to Electrical Service	5
SECTION III	OPERATION	
Paragraph	3-1 General	6
Paragraph	3-2 Operating Hoist	6
Paragraph	3-3 Pulling and Pivoting Hoist and Load	6
Paragraph	3-4 Upper and Lower Limit Stops	6
Paragraph	3-5 MAN-GUARD Overload Clutch Operations	7
Paragraph	3-6 Operating Precautions	7
SECTION IV	LUBRICATION	
Paragraph	4-1 General	8
Paragraph	4-2 Change Gear Case Oil	8
Paragraph	4-3 Lubricate Load Chain	8
Paragraph	4-4 Lubricate Upper Hook and Lower Block Assembly	8
Paragraph	4-5 Lubricate Limit Lever Control Shaft and Gears	9
SECTION V	MAINTENANCE	
Paragraph	5-1 General	9
Paragraph	5-2 Thirty-Day Inspection	9
Paragraph	5-3 Six-Month Inspection	12
Paragraph	5-4 Inspection 5000 Hour or Five Year	12
SECTION VI	TROUBLE SHOOTING CHART	13-14
SECTION VII	DISASSEMBLY AND REASSEMBLY	
Paragraph	7-1 General	14
Paragraph	7-2 Disassembly of Hoist Into Subassemblies	15
Paragraph	7-3 Rebuild of Hoist Frame, Sprocket Gear, Sprocket Shaft and Chain Guide	17
Paragraph	7-4 Rebuild of Load Brake and Overload Clutch Assembly	20
Paragraph	7-5 Rebuild of Lower Block and Load Chain Assembly	22
Paragraph	7-6 Rebuild of Electrical Controls and Gear Case Cover Subassembly	23
Paragraph	7-7 Rebuild of Push Button Station and Conductor Cable Assembly	23
Paragraph	7-8 Rebuild of Contactor Assembly (Push Button Models)	24
Paragraph	7-9 Rebuild of Single Phase Motor Assembly	24
Paragraph	7-10 Rebuild of Three Phase Motor Assembly	24
Paragraph	7-11 Reassembly of Hoist From Subassemblies	24
Paragraph	7-12 Testing Hoist	26
Paragraph	7-13 Test Procedure For Checking Operation of Overload Clutch	26
SECTION IX	REPLACEMENT PARTS	27-66

Notice: Information contained in this book is subject to change without notice.



Figure 1-1. Cutaway View Of Typical Budgit Electric Hoist

SECTION I - GENERAL DESCRIPTION

1-1. GENERAL. **Budgit** Portable Electric Hoists are precision built chain type hoists ranging in six rated load sizes from 1/4 ton thru 3 tons with various lifting speeds and electrical power supplies. In addition to the capacities, there are model variations with roller or link type load chains, hook or lug type suspension, and single or two speed. In addition to standard models, there are four rated load sizes of Budgit Electric Hoists ranging from 1/4 ton thru 2 tons suitable for plating hoist service with various lifting speeds and electrical power.

1-2. HOIST SERVICE CLASSIFICATION

a. **Budgit** electric hoists at the time of manufacture comply with our interpretation of applicable sections of ANSI B30.16 "Overhead Hoists", National Electric Code ANSI/ NFPA 70 and Occupational Safety and Health Act, 1992.

b. OSHA places the burden of compliance for hoist installations on the user. The user must install the equipment in accordance with the National Electric Code ANSI/NFPA 70 as well as other federal, state and local regulations which apply to the installation and application in your particular area.

⚠ WARNING

This equipment is not designed or suitable as a power source for lifting or lowering persons.

c. These hoists meet ANSI/ASME HST-1M "Performance Standard for Electric Chain Hoists" hoist duty class ratings as outlined in the sales bulletin.

1-3. BASIC CONSTRUCTION. All sizes and models of these **Budgit** Electric Hoists are of the same basic designs, having many common and interchangeable parts. They consist primarily of an aluminum alloy frame and gear case cover which houses an automatic load brake and gear train. An electric driving motor and external motor brake are mounted on the rear of the frame, Electrical control components are mounted on front of the gear case cover and encased by aluminum alloy end cover. An upper hook or lug bracket for suspending the hoist is attached to the top of the frame. Either a special nickel steel roller load chain or high strength low alloy coil load chain with lower block assembly is employed to raise and lower loads. A block and chain operated limit stop lever is mounted on the

bottom of the hoist frame and is connected, by linkage, to a limit switch. Hoist operation is controlled by a pendant push button station.

1-4. DIFFERENCES BETWEEN MODEL AND SIZES. The main differences between hoist models are in the service classification, type of load chain and the suspension employed. These are described in paragraphs (a) thru (d), below. The differences between sizes of hoists are in the number of gear reductions used and the reeving of the load chain. Two-reduction gearing is used for 1/4 thru 1/2 ton rated load hoists; three-reduction gearing for 1, 2 and 3 ton rated hoists. On 1/4 thru 1 ton rated load hoists, the load chain is single reeved (one part of chain); on 2 ton rated loads, the chain is double reeved (two parts of chain); on three ton rated loads, the chain is triple reeved (three parts of chain).

a. Two different types of load chains are used as the lifting medium, roller chain and link chain. The roller type chain is a special precision manufactured nickel steel chain. Link type chain is full-flexing electric welded link chain. Both are especially designed for use in **Budgit** Electric Hoists and only factory approved chain of the correct size, pitch, hardness, and strength can be used with these hoists.

b. Suspension differences include a conventional hook type mounting and a lug type mounting. Hook suspension allows portability permitting hoist to be easily moved from job to job. Lug suspension permits hoist to be rigidly mounted to overhead structure or attached to **Budgit** Rigid Mount Trolleys, affording unusual headroom advantage.

c. Some hoists are adaptations of standard model hoists to permit use in some mildly corrosive atmospheres, high ambient temperatures and high duty cycle operation. They are available only in link chain models in either hook or lug suspension. Construction variations from standard models are as follows:

- (1) Load chain is zinc plated for corrosion resistance.
- (2) All exposed aluminum parts are prime painted with corrosion resistant paint.
- (3) Aluminum castings are specially treated.

1-5. **MAN-GUARD OVERLOAD CLUTCH.** **Budgit** Electric Hoists having a **MAN-GUARD** label on the sides of the electrical compartment cover (fig. 1-2) are equipped with an overload clutch that is designed to help guard against excessive overloads. The clutch is built into the load brake gear. It is a cone-friction clutch that connects the first reduction gear (load brake gear) to the load brake output pinion shaft. A Belleville disc spring provides clutch pressure between the gear and its cone shaped gear center. An excessive overload causes the load brake gear to rotate without turning the gear center and output pinion shaft. The clutch is located between the load brake and the motor, thus allowing both load brake and motor brake to function in their normal manner. See paragraph 3-5 for operation.

SECTION II - INSTALLATION

2-1. GENERAL. **Budgit** Electric Hoists are completely lubricated and load tested under their own power before being shipped from the factory. To place hoist in service, attach to suitable overhead suspension (par. 2-2) in area to be used; make pre-installation check (par. 2-3); and connect to the proper power supply.

2-2. INSTALLATION.

CAUTION

Lubricate load chain before operating hoist. See paragraph 4.3

a. On hook suspended hoists, select a suitable overhead support in area hoist is to be used (one capable of holding weight of hoist and its rated load) and hang up hoist. Be certain upper hook is firmly seated in center of hook saddle. Upper hook is equipped with a spring type hook latch; it may be necessary to remove latch to attach hook to support. Replace latch after hoist is installed.

b. On lug suspended hoists, select a suitable overhead support in area hoist is to be used (one capable of holding weight of hoist and its rated load). Mount hoist using thru bolts, of appropriate size, to fit mounting holes in suspension lug at top of hoist frame. (See table below.) The structure used to suspend hoist must be of sufficient strength to withstand reasonable forces to which hoist and support may be subjected. Hoist must be aligned with load to avoid side pulls.

c. On lug suspended hoists, the suspension lug is installed for cross mounting, the recommended condition. To rotate hoist 90° for parallel mounting (a special condition), follow instructions below:

(1) On 1/4 thru 1 ton hoists remove suspension lug per instructions in Section VII, paragraph 7-3. c. (1) and figure 720. Lift lug from hoist frame, rotate to desired position and replace on locating pins. Insert suspension bolt and nut. Turn nut on top of lug while holding nut inside of hoist frame with drift until grooved pin holes are aligned. On later model hoists, loosen set screw, rotate hoists in 90° increments and tighten set screw.

WARNING

Be certain to replace grooved pin thru nut and suspension bolt.

(2) On 2 ton hoists, remove hex socket head screw in lower lock plate. Remove lower lock plate. Rotate suspension lug to selected position and replace lock plate and hex socket head screw.

(3) On 3 ton hoists, the hanger bracket must first be removed from the hoist to provide access to suspension nut per Section VII, par. 7-2. a. (4) and figures 7-2 and 7-3. To remove lug bolt, follow instructions in Section VII, par. 7-3. b. (3). With bolt removed lift lug from hanger and reposition as desired. The lug is located and prevented from turning by integral lugs on adjacent surfaces of the lug and the hanger. Reinstall suspension bolt, spherical washers and nut. Align hole in nut and suspension bolt. Reassemble hanger bracket to hoist.

WARNING

THE MAN-GUARD OVERLOAD CLUTCH IS A PROTECTIVE DEVICE THAT WILL PERMIT OPERATION OF YOUR HOIST WITHIN ITS RATED LOAD AND WILL PREVENT LIFTING OF EXCESSIVE OVERLOADS WHICH CAN CAUSE PERMANENT DEFORMATION OR WEAKENING OF A PROPERLY MAINTAINED HOIST AND/OR ITS SUSPENSION.

⚠WARNING

Be certain to replace grooved pin thru nut and suspension bolt.

d. On rigid mount trolley suspended hoists, the trolley side plates must be properly spaced so trolley will fit I-beam on which hoist will operate. Adjustment for various I-beam sizes is accomplished by rearrangement of spacer washers on thru bolts which connect trolley side plates to suspension lug on hoist. Refer to instruction sheet furnished with Budgit Rigid Mount Trolleys for complete instructions.

SUSPENSION LUG BOLT SIZES AND SPACING

Hoist Rated Load (tons)	Bolt Diameter (in)	Distance Between Holes (in)
1/4, 1/2 & 1	5/8	3-1/8
2	1	5
3	1-1/4	6

2-3. PRE-INSTALLATION CHECK.

Check Oil Level (Fig. 4-1). The gear case has been filled with oil, to the proper level at the factory. However, the oil level should be checked before hoist is operated. Remove and discard felt shipping plug from oil filler on side of hoist frame. Check oil level by removing oil level plug (side of frame). Observe if oil level is even with bottom of tapped hole. If it is not, add oil, as specified in paragraph 4-2. c. Also check load chain. Be sure it is properly lubricated. See paragraph 4-3.

2-4. CONNECTING HOIST TO ELECTRICAL SERVICE.

a. All hoists are equipped with a flexible power cable extending from the hoist. A grounding type male plug or permanent connection in an outlet box may be used for connecting hoist to power supply. See table (fig. 2-1) for branch circuit conductor sizes.

H.P.	Power Supply	AWG Wire Size					
		#16	#14	#12	#10	#8	#6
1/4	115-1-60	80	130	210	330		
	230-1-60	230	330	835			
	200, 230-3-60	465	740	1180			
	460, 575-3-60	1440	2390				
1/2	115-1-60	45	75	120	190	310	490
	230-1-60	195	305	490	775	1235	
	200, 230-3-60	280	450	715	1135		
	460, 575-3-60	860	1440				
1	115-1-60	*	45	75	120	190	300
	230-1-60	120	190	300	475	720	
	200, 230-3-60	180	290	460	730		
	460, 575-3-60	560	900				
2½	200, 230-3-60	60	100	150	250		
	460, 575-3-60	260	420				

*Do not use

Figure 2-1. Branch Circuit Conductor Size. Maximum length in feet for maximum wire size based on Horsepower and power supply. Wire size for entire length of branch circuit and permanent wiring to main feeder. Power supply measured at hoist, while running and with normal load, must not vary more than ±5% of voltage on motor nameplate.

b. Follow local & National Electrical Codes when providing electrical service to hoist. Connect power wires in accordance with appropriate wiring diagram. Power supply must be the same voltage, frequency and phase as specified on the hoist nameplate.

⚠WARNING

The green wire provided in the power supply cable is a grounding wire and must be connected to a proper ground. (Follow local code requirements and/or National Electrical Code Par. 250-57 or 250-59).

c. Dual voltage hoists with reconnected 230/460 volts, 3 phase, 60 hertz are (unless otherwise specified on customer's order) shipped from factory pre-connected for operation on 460 volts. If hoist is to be operated on 230 volts convert wiring by changing connections on terminal board. With hoist disconnected from power source, remove electrical compartment cover and reconnect terminal board leads. Also refer to Wiring Diagram.

d. Dual voltage hoists with reconnected 115/230 volts, 1 phase, 60 hertz are (unless otherwise specified on customer's order) shipped from factory pre-connected for operation on 230 volts. If hoists are to be operated on 115 volts convert wiring by changing connections on terminal board. With hoist disconnected from power source, remove electrical compartment cover and reconnect terminal board leads. Also refer to Wiring Diagram.

⚠WARNING

Serious damage to the hoist can occur with resulting hazard to operator and load. Three phase hoists must be properly phased each time they are installed or moved to a new power source or when service is performed on mainline (power source).

e. To properly phase the hoist follow these steps:

- (1) Temporarily connect hoist to power source.
- (2) Operate "↑" button briefly to determine direction of travel.
- (3) If hook raises, phase is correct and temporary connections should be made permanent.
- (4) **IF HOOK LOWERS, HOIST IS "REVERSE PHASED" AND MUST BE CORRECTED BY INTERCHANGING ANY TWO LEADS AT POWER SOURCE CONNECTION. DO NOT CHANGE INTERNAL WIRING OF HOIST.**

f. For connecting hoist to a motor driven trolley, refer to instructions furnished in trolley manual.

SECTION III - OPERATION

3-1. GENERAL. Operation of **Budgit** Electric Hoists is controlled by a push button station suspended from the hoist electrical compartment. The station has a built-in mechanical interlock to prevent depressing both buttons simultaneously.

3-2. OPERATING HOIST.

a. Depress push button marked “↑” to raise load. b. Depress push button marked “↓” to lower loads.

c. Jogging the push buttons will give “hairline” load movement. The quickness of the depressing motion will determine the amount of movement. Excessive use of this “jogging” feature will cause premature burning of contact points, motor overheating, and rapid motor brake wear.

3-3. PULLING AND PIVOTING HOIST AND LOAD.

a. The push button station conductor cable has a built-in strain cable suitable for pulling trolley suspended hoists when not loaded. Do not use for pulling bridge cranes. Push on load or load chain or use a hand geared or motor driven type trolley to traverse loaded hoists.

b. To pivot hoist and load, push on one corner of load. The lower hook will pivot thru 360 degrees to permit load to be swung to the desired position. The upper hook (hook suspension models) is also designed to rotate so that side pulls will swing hoist to face load, thus reducing side thrust.

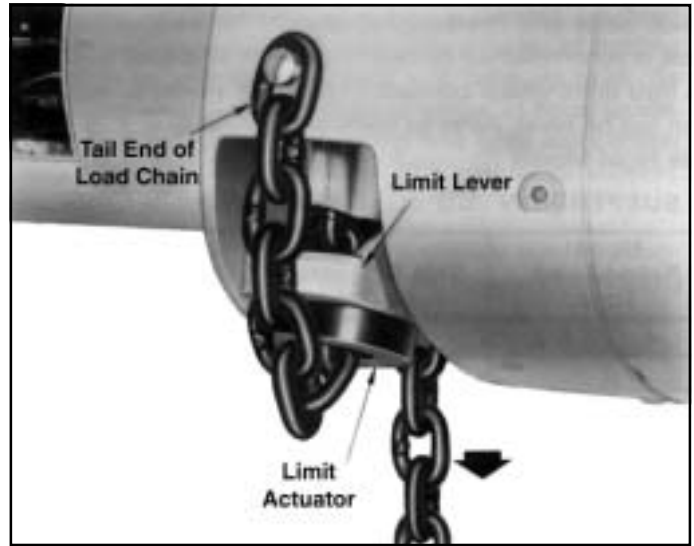

Figure 3-2. Limit Lever Being Tripped By Actuator on Tail End of a Load Chain

NOTE: On lug type, link chain hoists, the limit lever may be tripped by the load chain during side pulls. Load must be lined up with hoist. If moderate side pulls cannot be avoided, rotate hoist 90° so it is mounted with side of hoist facing direction of side pull. See appropriate instruction in Section II, paragraph 2-2. c.

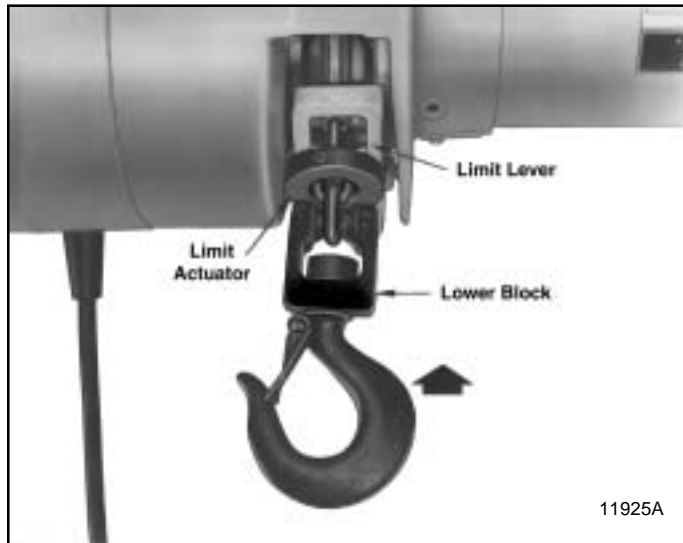

Figure 3-1. Limit Lever Being Tripped By Actuator Above Lower Block on Single Line Hoist

3-4. UPPER AND LOWER LIMIT STOPS. A lower block and chain operated limit stop is provided to guard against overtravel of load in either raising or lowering direction, which can cause damage to hoist. When highest position is reached, limit actuator on the load chain, above the lower block, trips the limit lever (fig. 3-1). When lowest position is reached, a limit actuator on the tail end of load chain trips the limit lever (fig. 3-2). The limit lever is connected to a limit switch that automatically stops the hoist motor. This is intended as a safety device and should not be used on a routine basis to stop travel of lower block or shut off hoist.

3-5. OVERLOAD CLUTCH OPERATION. The overload clutch is factory preset at assembly so that the hoist will lift its full rated load but will refuse to lift overloads within a range of 110 percent rated load to 180 percent rated load. If the load to be lifted exceeds the clutch factory setting, the motor will continue to run and will rotate the load brake gear without lifting the load. Whenever this occurs, immediately release the “↑” push button to prevent overheating of the clutch friction surfaces and motor, and reduce the load to rated hoist capacity. Should it be impractical to reduce the load, replace the hoist with one of suitable rated capacity.

NOTE: Always know load to be lifted. **Yale•Lift-Tech** does not recommend lifting loads greater than the rated load of your hoist.

3-6. OPERATING PRECAUTIONS.

▲WARNING

Equipment covered herein is not designed or suitable as a power source for lifting or lowering persons. Do not use as an elevator.

Safe operation of an overhead hoist is the operator's responsibility. Listed below are some basic rules that can make an operator aware of dangerous practices to avoid and precautions to take for his own safety and the safety of others. Observance of these rules in addition to frequent examinations and periodic inspection of the equipment may save injury to personnel and damage to equipment.

- a. DO read ANSI B30.16 Safety Standard for Overhead Hoists and the Operation, Service and Parts Manual
- b. DO be familiar with hoist operating controls, procedures and warnings.
- c. DO make sure hook travel is in the same direction as shown on controls.
- d. DO make sure hoist limit switches function properly.
- e. DO maintain firm footing when operating hoist.
- f. DO make sure that load slings or other approved single attachments are properly sized and seated in the hook saddle.
- g. DO make sure that the hook latch, if used, is closed and not supporting any part of the load.
- h. DO make sure that load is free to move and will clear all obstructions.
- i. DO take up slack carefully, check load balance, lift a few inches and check load holding action before continuing.
- j. DO avoid swinging of load or load hook.
- k. DO make sure that all persons stay clear of the suspended load.
- l. DO warn personnel of an approaching load.
- m. DO protect load chain from weld splatter or other damaging contaminants.
- n. DO promptly report any malfunction, unusual performance, or damage of the hoist.
- o. DO inspect hoist regularly, replace damaged or worn parts, and keep appropriate records of maintenance.
- p. DO use the hoist manufacturer's recommended parts when repairing a hoist.
- q. DO use hook latches wherever possible.
- r. DO apply lubricant to load chain as recommendeds. DO NOT lift more than rated load.
- t. DO NOT use the hoist load limiting device to measure the load.
- u. DO NOT use damaged hoist or hoist that is not working correctly.
- v. DO NOT use the hoist with twisted, kinked, damaged or worn chain.
- w. DO NOT lift a load unless chain is properly seated in chain wheel(s) or sprocket(s).
- x. DO NOT use load chain as a sling or wrap chain around the load.
- y. DO NOT lift a load if any binding prevents equal loading on all supporting chains.
- z. DO NOT apply the load to the tip of the hook.
- aa. DO NOT operate unless load is centered under hoist.
- ab. DO NOT allow your attention to be diverted from operating the hoist.
- ac. DO NOT operate the hoist beyond limits of load chain travel.
- ad. DO NOT use limit switches as routine operating stops unless recommended. They are emergency devices only.
- ae. DO NOT use hoist to lift, support or transport people.
- af. DO NOT lift loads over people.
- ag. DO NOT leave a suspended load unattended unless specific precautions have been taken.
- ah. DO NOT allow sharp contact between two hoists or between hoist and obstructions.
- ai. DO NOT allow the chain or hook to be used as a ground for welding.
- aj. DO NOT allow the chain or hook to be touched by a live welding electrode.
- ak. DO NOT remove or obscure the warnings on the hoist.
- al. DO NOT adjust or repair a hoist unless qualified to perform hoist maintenance.
- am. DO NOT attempt to lengthen the load chain or repair damaged load chain.
- an. DO NOT allow personnel not physically fit or properly qualified to operate the hoist.
- ao. DO NOT operate hoist unless upper and lower limit switch stops are operating properly.
- ap. DO always be sure there is not twist in link load chain. On 2 & 3 ton link chain hoists, check to see that lower block is not capsized between strands of chain.
- aq. DO avoid operating hoist when hook is not centered under hoist. Be sure that hoist trolley or other support mechanism is correctly positioned for handling the load before lifting.
- ar. DO operate hoist within recommended duty cycle and do not "jog" unnecessarily.
- as. DO conduct regular visual inspections for signs of damage or wear.
- at. DO NOT operate hoist with hooks that have opened up. See Figures 5-5 and 5-6.
- au. DO provide supporting structure or anchoring means that has a load rating at least equal to that of the hoist.
- av. DO NOT use hoists in locations that will not allow operator movement to be free of the load.
- aw. DO when starting to lift or pull, move the load a few inches at which time the hoist should be checked for proper load holding action. The operation shall be continued only after the operator is assured that the hoist is operating properly.
- ax. DO NOT leave a loaded hoist unattended at the end of a work shift or for extended periods during the work shift. Where operations are such that this condition cannot be avoided the operator must be assured that the condition does not create a hazard to personnel or property.

ay. **DO use common sense and best judgement whenever operating a hoist. Observe American National Standard Safety standard, ANSI B30.16, latest issue.**

SECTION IV - LUBRICATION

4-1. GENERAL. The lubrication services outlined in paragraphs 4-2 thru 4-5 should be performed at regular intervals to maintain top hoist performance and insure long life. The frequency for lubrication services will depend on the type of hoisting service that hoist is subjected to and should coincide with periodic preventive maintenance inspection. See Section V-Maintenance.

4-2. CHANGE GEAR CASE OIL (Fig. 4-1).

a. Remove drain plug from bottom of hoist frame and drain oil from gear case. Replace plug.

b. Remove oil level plug from side of hoist.

c. Refill gearcase thru oil filler to proper level (bottom of oil level plug hole) using Automatic Transmission Fluid - DEXRON Type. This is an all-weather oil available from all major oil companies. 1-1/2 pints of oil are required.

d. Reinstall oil level plug.

4-3. LUBRICATE LOAD CHAIN. A small amount of lubricant will greatly increase load chain life, therefore, chain should not be allowed to run without lubricant. Chain should be cleaned and lubricated as directed in paragraphs a. and b. below, depending upon type of chain. User should set up a regular schedule for chain lubrication after observing operating conditions for a few days. Use Bar and Chain Oil (LUBRIPLATE or equal) on load chain.

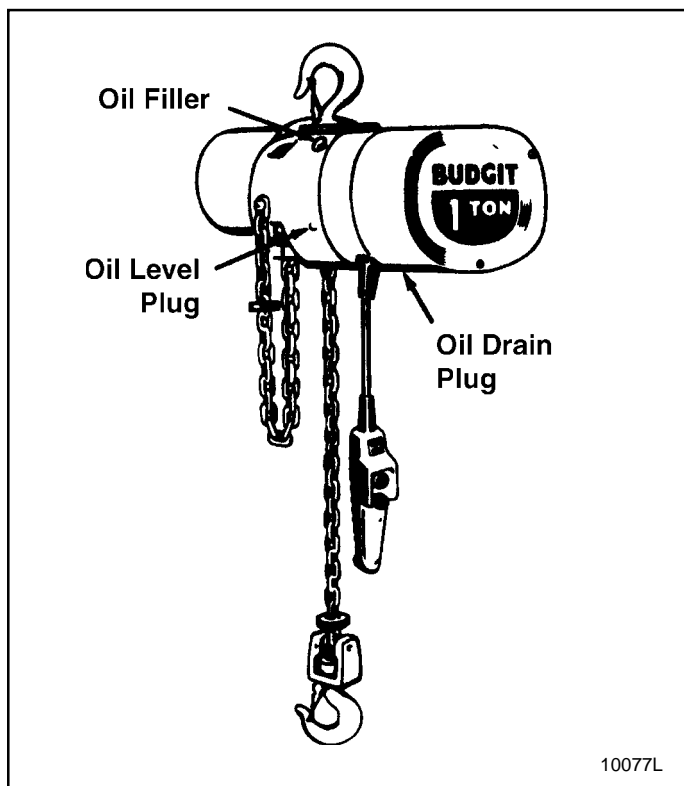

Figure 4-1. Location of Oil Filler and Plugs

a. Link Chain. Under ordinary conditions only weekly attention will be necessary. Under hot and dirty conditions it may be necessary to clean chain at least once a day and lubricate it several times between cleanings. Thoroughly clean chain with an oil solvent and re-lubricate by coating it lightly with oil. Make sure that lubricant coats wear surfaces between links. Zinc plated load chain should be cleaned and lubricated daily.

b. Roller Chain. Under ordinary conditions only monthly attention will be necessary. Under hot and dirty conditions weekly attention may be required. Thoroughly clean chain with an oil solvent and apply oil. Wipe off excess oil. When subjected to excessive moisture or corrosive atmospheres, DO (dripless oil) lubricant from American Grease Stick Company is recommended for use on roller chain in place of regular oil.

4-4. LUBRICATE UPPER HOOK AND LOWER BLOCK ASSEMBLY.

a. Apply a few drops of Bar and Chain Oil on shank of upper hook where it enters frame.

b. Apply a few drops of Bar and Chain Oil on shank of lower hook where it enters lower block. Hook rotation bearing may be removed for cleaning and re-lubricating if necessary. See paragraph 7-5.

c. On lower block assemblies of 2 thru 5 ton capacity hoists, also apply heavy duty lithium soap grease with EP additives thru pressure fitting in end of sprocket pin to lubricate bearing in chain sprocket.

d. On 3 ton model lubricate sprocket in hanger bracket with a few drops of Bar and Chain Oil in hole provided in center of sprocket hub.

4-5. LUBRICATE LIMIT LEVER CONTROL SHAFT AND GEARS.

Apply a few drops of Bar and Chain Oil on limit lever shaft at bearing points.

⚠ WARNING

Before performing any internal work on hoist, be certain power is shut off. Lock main service switch in the open position.

SECTION V - MAINTENANCE

5-1. GENERAL. Preventive maintenance services required on **Budgit** Electric Hoists are for the most part, simple periodic inspection procedures to determine condition of hoist components. Below are suggested inspection procedures, based on daily average hoist usage.

5-2. THIRTY-DAY INSPECTION. Hoist may be left suspended.

a. Inspect Load Chain.

(1) Operate hoist under load and observe operation of chain over sprocket in both directions of chain travel. Chain should feed smoothly into and away from the sprocket. If chain binds, jumps or is noisy, first see that it is clean and properly lubricated. If trouble persists, inspect chain as outlined below, depending on type of chain.

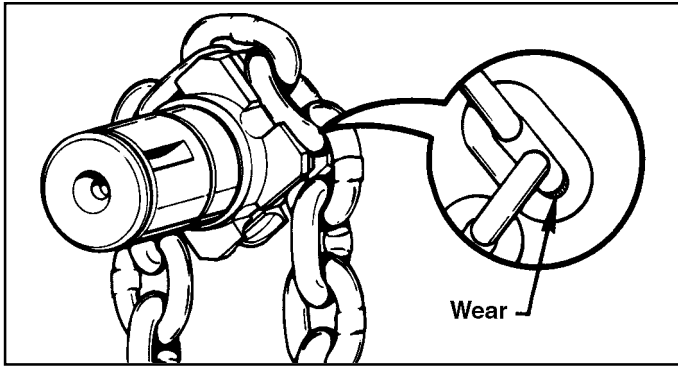

Figure 5-1. Check Chain Wear at Bearing Surfaces Between Links

(2) **Link Type Load Chain.** Clean chain for inspection. Examine visually for gouges, nicks, weld spatter, corrosion or distorted links. Slacken chain and check bearing surfaces between links for wear, fig. 5-1. Greatest wear will often occur at sprocket at high or low point of lift, particularly when hoist is subjected to repetitive lifting cycles. Case hardness of chain is about .015" deep. Chain must be replaced before the case is worn thru. Also check chain for elongation using a vernier caliper (fig. 5-2). Select an unworn, unstretched section of chain (usually at slack or tail end) and measure and record the length over the number of chain links (pitches) indicated in figure 5-2. Measure and record the same length of a worn section in the load side of the chain. Obtain the amount of wear by subtracting the measurement of the unworn section from the measurement of the worn section. If the result (amount of wear) is greater than the amount specified in the "ALLOWABLE CHAIN WEAR" table, the chain has elongated beyond the maximum allowable length and must be replaced. Chain with excessively pitted, corroded, nicked, gouged, twisted or worn links should be replaced using only factory approved chain. Never weld or attempt to repair link chain.

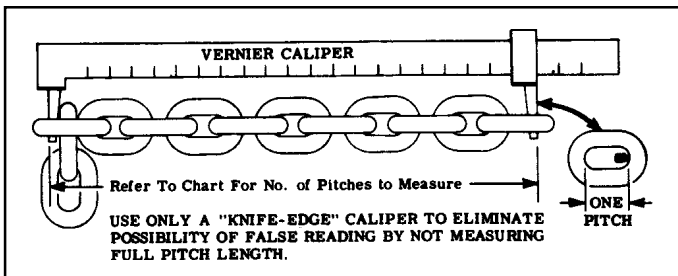

Figure 5-2. Check Coil Chain Using Vernier Caliper

ALLOWABLE CHAIN WEAR - ELONGATION

Hoist Rated Load (tons)	Chain Size (wire dia.)	No. of Pitches to Measure	Maximum Wear Limit
1/4 & 1/2	1/4"	13	.145"
1 thru 3	5/16"	11	.142"

⚠ CAUTION

Do not assume that load chain is safe because it measures below replacement points given herein. Other factors, such as those mentioned in visual checks above, may render chain unsafe or ready for replacement long before elongation replacement is necessary.

⚠ WARNING

To avoid serious personal injury from a dropped load caused by possible chain breakage, when replacing link load chain, use only factory approved chain conforming to Budgit hoist specifications for material, hardness, strength and link dimensions. Chain not conforming to factory Specifications may be dangerous as it will not fit in the load sprocket and chain guide correctly, causing serious internal damage to hoist and it will wear prematurely, deform and eventually break.

(3) Removing and Replacing Link Load Chain.

(a) Replacement link load chain is installed by attaching it to tail end of old chain, after disconnecting old chain from side of hoist frame and removing limit actuator. New chain is then run into hoist as old chain is run out. Use open "C" links, figures 5-3 and 5-4, for attaching chains. Links must be identical in size to hoist chain - 1/4" wire size with .745" pitch length for 1/4 thru 1/2 ton models, 5/16" wire size with .858" pitch for 1 thru 3 ton models. Be certain that all welds on links of replacement chain face away from center of load sprocket.

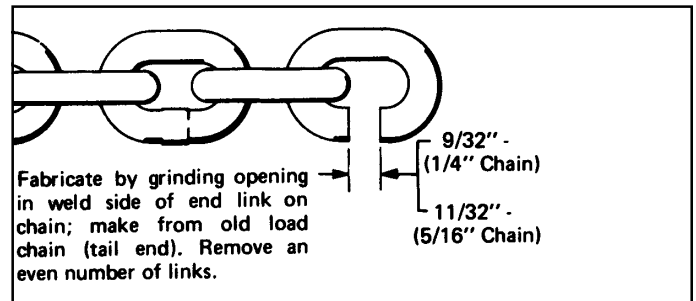

Figure 5-3. Open "C" Link for Removing and Installing Link Load Chain

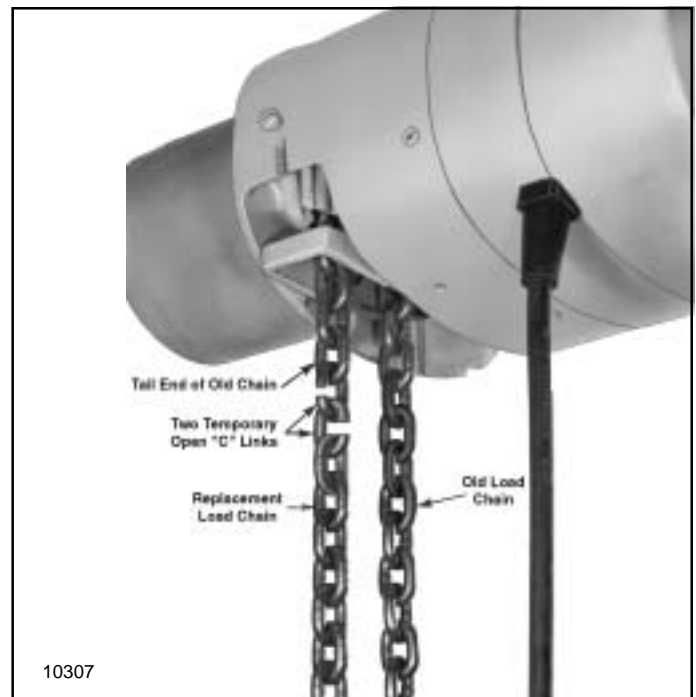

Figure 5-4. Installing Coil Load Chain Using Two "C" Links (1/4, 1/2 & 1 ton hoists)

(b) Remove lower block assembly and actuator from old chain and attach them to replacement chain at end which was just run thru hoist. Install limit actuator (as noted below) on other end of chain and anchor chain to side of hoist frame.

CAUTION

Two "C" links must be used on 1/4, 1/2 and 1 ton capacity hoists (fig. 5-4) in order to correctly position end link on tail end of chain to fit tail end anchor at side of hoist frame; only one "C" link is required on 2 thru 3 ton capacity hoists.

NOTE: Install limit actuator on the 8th link from the end and secure with grooved pin.

On 2 ton double reeved models, also connect opposite end of chain (from lower block) to load chain anchor inside of frame. On 3 ton triple reeved models, the opposite end of the chain is attached to the lower block connecting link.

NOTE: In the event the old chain is to be removed from hoist and reinstalled, a short length of chain (about 18" long) must be run into hoist when the old chain is removed. This short length can then be used in the same manner as shown in paragraph 5-2. a.(3). Be sure to use the proper number of open "C" links in order to correctly position end link on tail end of chain to fit anchor at side of hoist frame.

CAUTION

To avoid serious internal damage to hoist, when installing link load chain do not attempt to hand feed chain into hoist, or use a piece of wire in place of the method described herein. To do so may result in serious internal damage to hoist, as link chain links must be properly seated in chain sprocket before chain is run into hoist. Install chain only as described in this manual.

WARNING

Keep fingers clear of chain sprocket when replacing link load chain.

(4) Roller Type Load Chain. Visually check for possible twists, broken links, wear or elongation. Any links that do not flex easily, even when lubricated, may be damaged and should be replaced. Check roller chains for elongation from wear by pulling chain taut and measuring as follows: On RC-625, 625 or H-5 size chain (5/8" pitch), measure distance over a length of 20 pitches (center-to-center distance, between 21 rivets) - it must not exceed 12-3/4 inches. On RC-750, H-6 or HF size chain (3/4" pitch) measure length of 16 pitches (center-to-center distance between 17 rivets) - it must not exceed 12-1/4 inches. If chain exceeds the limit, replace damaged section or install new load chain assembly. Check chain for twist. If twist in any 5 foot extension exceeds 15 degrees, replace chain. Check chain for camber. If any section has side bow exceeding 1/4 inch in five feet, replace chain.

CAUTION

Do not assume that load chain is safe because it measures below replacement points given herein. Other factors, such as those mentioned in visual checks, may render chain unsafe or ready for replacement long before elongation replacement is necessary. **Do not attempt to splice the chain to replace worn or damaged sections unless you have the required equipment to properly spin rivet heads. It is suggested that you have this done by an authorized Budgit Repair Station that is equipped with the necessary special tools.**

WARNING

When replacing roller type load chain, use only factory approved chain conforming to factory specifications for material, hardness, tensile strength, size and construction. Budgit Hoist Roller chain is specially designed for hoisting service and is the only type roller chain that can safely be used with Budgit electric hoists. Chain not conforming to Budgit Roller Chain specifications may be dangerous as it will not withstand heavy impact loads and does not have adequate tensile strength.

(5) Check anchor end of chain at side of hoist frame for damage to last link, also connecting link on roller chain hoists. Replace damaged parts.

(6) Check connection of chain to lower block on 1/4 thru 1, 3, and 5 ton hoists. Replace parts showing evidence of damage, twisting or elongation.

(7) Check connection of chain to anchor inside hoist frame on double-reeved, 2-ton hoists. Replace parts showing evidence of damage, twisting or elongation. (Also see Sec. VII, par. 7-2. a. (2)).

(8) Lubricate load chain before using hoist. See paragraph 4-3, Section IV.

b. Inspect Lower Block.

(1) Check for bent or distorted hook. If hook is opened beyond the dimension given in figure 5-5, it must be replaced. Also check to see that hook swivels and is free to pivot. Lubricate these points if necessary.

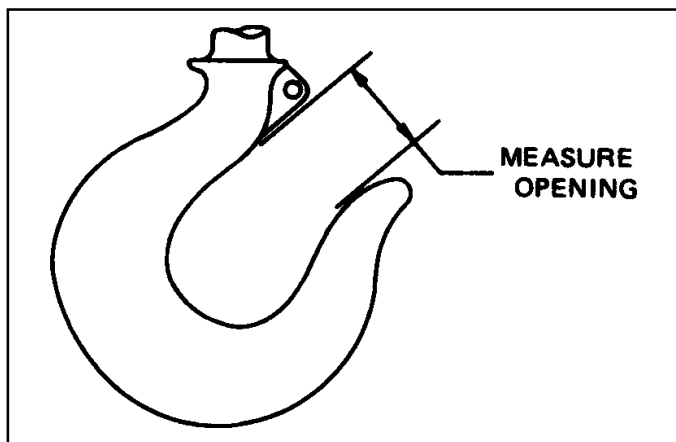

Figure 5-5. Lower Hook Opening (Shown with latch removed for clarity.)

Hoist Rated Load (tons)	Hook Throat Opening	
	Normal Opening	Replace Hook if Opening is Greater Than
1/4 & 1/2	1-1/8	1-1/4
1	1-1/4	1-7/16
2	1-3/8	1-9/16
3	1-1/2	1-11/16

(2) On 2 thru 3 ton hoists, check sprockets and bearings in lower block for freedom of movement and signs of damage. Lubricate if necessary. Replace damaged parts.

(3) Check hook latches. Replace damaged or bent latches or broken springs.

▲ CAUTION
<p>Hooks, upper or lower, damaged from chemicals, deformation or cracks or having more than 15 percent in excess of normal throat opening or more that 10 degrees twist from the plane of the unbent hook, or opened, allowing the hook latch to bypass hook tip must be replaced. Any hook that is twisted or has excessive throat opening indicates abuse or overloading of the hoist. Other load bearing components of the hoist should be inspected for damage. (See Section V. Par. 5-2. d. (2) below).</p>

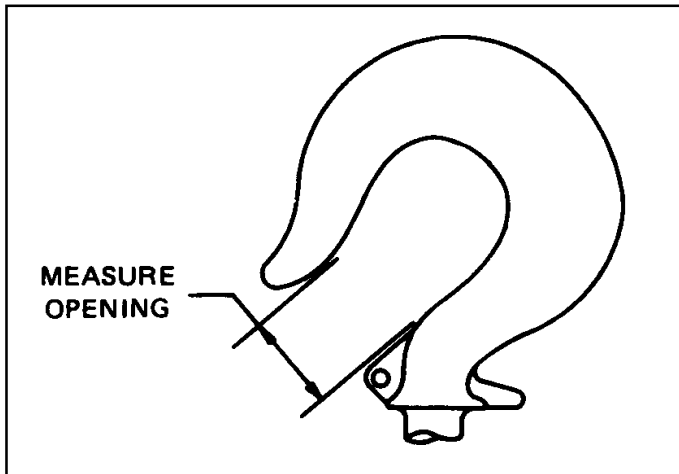

Hoist Rated Load (tons)	Hook Throat Opening	
	Normal Opening	Replace Hook if Opening is Greater Than
1/4 & 1/2	1-1/8	1-1/4
1	1-1/4	1-7/16
2	1-3/8	1-9/16
3	1-1/2	1-11/16

Figure 5-6. Upper Hook Opening (Shown with latch removed for clarity.)

c. Inspect Upper Suspension.

(1) On hook suspended models, check for bent or distorted hook. If hook is opened beyond the dimension given in figure 5-6, it must be replaced. Also check to see that hook pivots. Lubricate if necessary.

(2) On lug suspended models, check condition of suspension lug. Replace lug if damaged or cracked. Check to see that lock plate is in place on lug and screw holding it is tight.

(3) On 2-ton hoists, check to see that upper lock plate securing hook or lug bushing is in place and screws holding it are tight. Lubricate hook shank.

(4) Check hook latch. Replace damaged or broken parts.

d. Inspect Motor, Frame and Electrical Compartment Cover.

(1) Check to see that bolts securing motor to frame are tight. Also check for any visible damage to motor, such as a cracked end bell or dented stator housing. Replace damaged parts.

(2) Check hoist frame for signs of visible damage. If frame shows evidence of fracture, the hoist should be disassembled and inspected for further signs of damage from possible overloading. Replace damaged parts. Also check condition of limit lever.

(3) Check for possible damage to electrical compartment cover. Be sure screws holding cover are tight.

e. Check Oil Level. Remove oil level plug (fig. 4-1). If oil level is not even with bottom of tapped hole, add Automatic Transmission Fluid, DEXRON Type, to bring to proper level.

5-3. SIX-MONTH INSPECTION OR 500-750 HOURS OF OPERATION. Hoist may be left suspended.

a. Inspect Electrical Controls. Shut off power supply to hoist and remove electrical compartment cover from hoist. Use caution as some covers contain counterweights. Two speed hoists with a 2-1/4 horsepower motor have an externally mounted counterweight at the electrical compartment cover.

(1) Check all wiring and terminals. Insulation should be sound and terminals securely crimped to wires. Terminal screws should be tight and plug-type terminals completely mated. Replace terminals or wires as necessary.

(2) Check control circuit transformer for evidence of overheating. Replace if necessary.

(3) Check control shaft centering spring by operating limit lever. If limit lever does not return to neutral position after it is tripped, the spring is probably broken or control shaft is bent. Replace broken or damaged parts.

(4) Check limit switch to see that wires are securely soldered and mounting screws are tight.

(5) Check contactor solenoid coils and replace coils if they show evidence of overheating.

(6) Check control cable wire strain reliever to see that it is in good condition and securely attached to gear case cover. Replace rubber strain reliever grommets if damaged.

b. Change Gear Case Oil. See Section IV, paragraph 4-2.

c. Relubricate Load Chain. See Section IV, paragraph 4-3.

d. **Lubricate Upper Hook and Lower Block.** See Section IV, paragraph 4-4.

e. **Lubricate Limit Lever Control Shaft.** See Section IV, paragraph 4-5.

5-4. INSPECTION: 5000 HOURS "ON" TIME OR 5 YEARS ELAPSED TIME. Hoist must be removed from overhead suspension.

a. **Disassemble Hoist into Subassemblies.** Follow procedure outlined in Section VII, paragraph 7-2.

b. Motor shaft oil seal, sprocket shaft bearing and seal, guide pin "0" rings and all gaskets should be replaced.

c. **Inspect Load Brake and Overload Clutch.** Disassemble load brake and clutch assembly as outlined in paragraph 7-4. Friction discs should be discarded and replaced with new discs. Check load brake friction surfaces on flange, ratchet assembly and gear clutch cone. Replace parts if badly scored or worn. Check condition of pawl and ratchet assembly. If pawl, ratchet teeth or pawl spring are broken, damaged or badly worn, replace complete assembly. Check contact faces of load brake cam and gear clutch cone. Brake gear and pinion teeth should be inspected for wear or broken teeth. Clean parts thoroughly with an oil solvent before reassembly.

NOTE: The overload clutch assembly should not be disassembled as it is preset at the factory to provide proper clutch pressure for a specific hoist capacity range. If there is evidence of the clutch slipping or wear or damage to the clutch components, the complete clutch assembly should be replaced or sent to an authorized Budget Hoist Repair Station to be rebuilt and properly adjusted to factory specifications.

d. **Inspect Sprocket and Intermediate Gears.**

(1) On 1 thru 5 ton hoists, check condition of gear teeth on intermediate gear and pinion shaft assembly. Replace worn or damaged parts.

(2) Check condition of teeth or pockets on chain sprocket (all capacities). Replace worn or damaged parts.

e. **Inspect Motor Brake.** For access to motor brake parts, except for two speed, remove motor assembly as outlined in paragraph 7-2. d. Then, remove brake parts following instructions given for the specific type brake, depending upon model of hoist. Check braking surfaces for wear and scoring. Replace badly worn or scored parts. Check to see that plate support pins inside frame are tight. Check large compression spring and spring plunger. Replace parts that are worn or damaged.

For two speed hoist, remove brake housing screws, housing, support plate screws, support plate assembly, friction disc and stationary discs. Check braking surfaces for wear and scoring. Replace badly worn or scored parts.

f. **Reassemble and Test Hoist.** Reassemble hoist from subassemblies following procedure outlined in paragraph 7-11. After assembly is complete, test hoist as outlined in paragraphs 7-12 and 7-13.

SECTION VI - TROUBLE SHOOTING

Trouble	Probable Cause	Remedy
6-1. Hoist Will Not Operate.	<p>a. No power to hoist.</p> <p>b. Wrong voltage.</p> <p>c. No control voltage.</p> <p>d. Loose or broken wire connections in hoist electrical system.</p> <p>e. Contactor assembly not functioning.</p> <p>f. Starting switch burned out (single phase motor).</p> <p>g. Motor burned out.</p>	<p>a. Check switches, circuit breakers and connections in power supply lines. Check power collectors.</p> <p>b. Check voltage required on motor data plate against power supply.</p> <p>c. Check transformer fuse. If blown, check for grounding and/or short in the pushbutton station. Check the transformer coil for signs of overheating. Replace transformer if burned out. Verify the transformer secondary is the same voltage as the coils to which it is connected.</p> <p>d. Shut off power supply, remove electrical cover from hoist and check wiring connections. Also check connections in push button station and limit switches.</p> <p>e. Check for burned out solenoid coil. See that the necessary jumper wires are properly installed.</p> <p>f. Replace burned out parts.</p> <p>g. Replace motor. On single-phase motors the starting switch may be burned out.</p>
6-2. Hook Moves in Wrong Direction.	<p>a. Reverse phasing on three-phase hoists.</p> <p>b. Hoist wired wrong.</p> <p>c. Starting switch not working correctly (single phase motor).</p>	<p>a. Interchange any two of the three power supply line leads. Do not change green ground lead. Refer to Section II, par. 2-4.</p> <p>b. Check wiring connections with appropriate wiring diagram.</p> <p>c. Check for correct starting switch part number and function. Replace if necessary.</p>
6-3. Hook Will Raise But Not Lower.	<p>a. "DOWN" electrical circuit open.</p> <p>b. Contactor assembly not functioning.</p> <p>c. Push Button Inoperative.</p> <p>d. Load Brake locked up and overload clutch slipping.</p>	<p>a. Check for loose connections. See that necessary jumper wires are properly installed on contactor. Check limit switch condition and electrical connections.</p> <p>b. See that necessary jumper wires are properly installed. Verify that the contactor armatures are free to move. If binding occurs replace contactor. Check for burned out contactor coils.</p> <p>c. Check push button contacts and wires.</p> <p>d. Consult Authorized Budgit Hoist Repair Station.</p>

SECTION VI - TROUBLE SHOOTING (Continued)

Trouble	Probable Cause	Remedy
6-4. Hook Will Lower But Not Raise	<ul style="list-style-type: none"> a. Excessive load, causing overload clutch to slip. b. Overload clutch out of adjustment. c. "UP" electrical circuit open. d. Contactor assembly not functioning. e. Push button inoperative. 	<ul style="list-style-type: none"> a. Reduce loading to rated load of hoist, as shown on nameplate. b. Test hoist and replace clutch if hoist will not lift rated load. c. Check for loose connections. See that necessary jumper wires are properly installed on contactor. Check limit switch condition and electrical connections. d. See that necessary jumper wires are properly installed. Verify that the contactor armatures are free to move. If binding occurs replace contactor. Check for burned out contactor coils. e. Check push button contacts and wires.
6-5. Hoist Will Not Lift Rated Load.	<ul style="list-style-type: none"> a. Low voltage b. Overload clutch out of adjustment. c. Motor brake not releasing. 	<ul style="list-style-type: none"> a. See that power supply is same voltage listed on motor data plate. Check size of power supply lines. Refer to fig. 2-1. b. Remove and replace clutch assembly. Refer to Section IV, par. 7-2 and 7-4. c. Check brake components. Refer to Section VII, par 7-2.d, 7-2.e and 7-2.f.
6-6. Excessive Drift When Stopping.	<ul style="list-style-type: none"> a. Excessive load. b. Motor brake not holding. c. Motor brake not setting due to insufficient plunger air gap. d. Load brake not holding. 	<ul style="list-style-type: none"> a. Reduce loading to rated load, shown on nameplate. b. Check brake components. Refer to Section VII, par. 7-2.d. c. Adjust air gap. Refer to Section VII, par. 7-11.c. d. Remove load brake and inspect parts. Refer to Section V, par. 5-4.
6-7. Hoist motor overheats.	<ul style="list-style-type: none"> a. Excessive load. b. Excessive duty-cycle. c. Excessive "jogging." d. Wrong voltage. e. Starting switch on single-phase motors not opening starting winding. f. Damaged motor or worn bearings in motor or hoist frame. g. Motor brake not releasing. 	<ul style="list-style-type: none"> a. Reduce loading to rated load of hoist, shown on nameplate b. Reduce frequency of lift. c. Reduce frequency of jogs. d. Check voltage rating on motor data plate against power supply. e. Refer to Section VII, par. 7-9.b. (3) (b). Inspect Switch. f. Disassemble hoist and inspect for worn or damaged parts. g. Check brake components. Refer to Section VII, par. 7-2.d.

SECTION VII - DISASSEMBLY AND REASSEMBLY

7-1. GENERAL.

a. The following disassembly and reassembly instructions apply to all models in the line of **Budgit** Electric Hoists with 4 digit catalog numbers and equipped with **MAN-GUARD** overload clutch. Where needed, variations to instructions are provided to cover differences between models (suspensions, load chains,

rated load sizes and motor voltage ratings), with applicable models specifically noted.

b. A complete teardown procedure is given, however, if only certain parts require repair or replacement, a partial teardown may be performed using the applicable portions of the instructions.

c. For easier handling during disassembly, the following disassembly steps may, where conditions permit, be completed before hoist is removed from its overhead suspension or

disconnected from its power supply: Remove chain container, if hoist is so equipped; remove lower block and load chain assembly, following procedure outlined in paragraph 7-2. a. Drain and discard gear case oil, by removing plug at bottom of frame.

d. These hoists contain precision machined parts and should be handled with care at disassembly and at reassembly. When removing or installing parts with press fits, be careful to apply pressure evenly. On ball bearings, apply pressure to face of inner or outer race, whichever is adjacent to mating part. This will avoid damage to bearing races from brinelling by pressing thru bearing balls. Apply a thin film of sealant to parts having a press fit when they are installed.

7-2. DISASSEMBLY OF HOIST INTO SUBASSEMBLIES.

a. Removal of Lower Block and Load Chain Subassembly.

(1) On models with single-reeved load chains (1/4 thru 1 ton rated loads) disconnect tail end of load chain from anchor at side of frame. Remove spring clip and connecting link attaching chain to anchor on roller chain models (fig. 7-1). Remove fillister head screw holding end link to frame on link chain models. Remove grooved pin from the limit actuator and pull it off end of chain. With hoist connected to power supply, run chain out of hoist by operating in "lowering" direction. (See note following paragraph (2) below and note in Sec. V, par. 5-2. a. (3) for inserting short length of chain.)

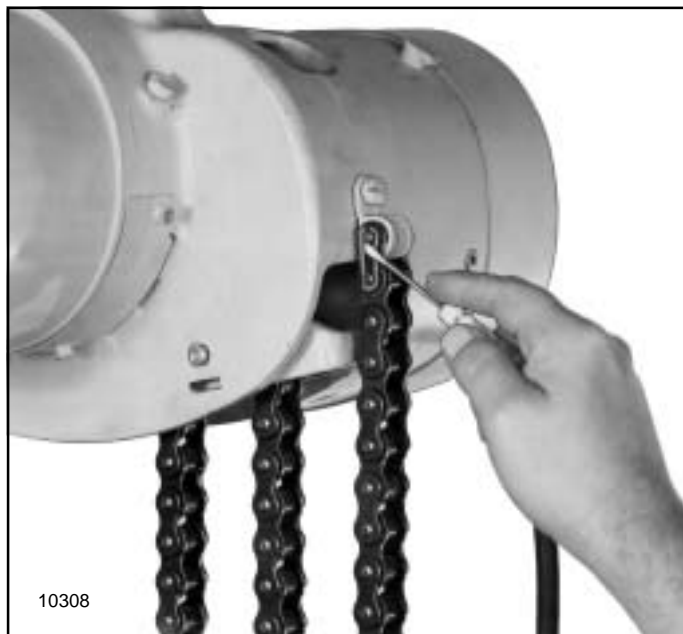

Figure 7-1. Removing Spring Clip from Connecting Link at Tail End of Load Chain (Roller Chain Models)

(2) On models with double-reeved load chains (2 ton hoists) disconnect tail end of load chain from anchor at side of hoist frame and remove limit actuator as in (1) above, run chain out of hoist by operating it in "lowering" direction, and disconnect opposite end of load chain from anchor inside hoist frame. To disconnect this end of chain, remove cotter pin from end of anchor pin, press pin from anchor and withdraw chain. On roller chain models the anchor in hoist frame must be rotated about 90° to permit removal of anchor pin. The drive pin securing threaded end of anchor in upper block assembly (at top of frame) must be removed in order to rotate the anchor.

NOTE: If hoist is inoperative it will be necessary to wait until after load brake is removed (par. c., below), then the chain can be pulled thru the hoist by hand.

(3) On triple-reeved 3 ton link chain hoists, remove retaining ring and connecting link pin as shown in figures 7-30 and 7-31. Remove connecting link with chain from lower block.

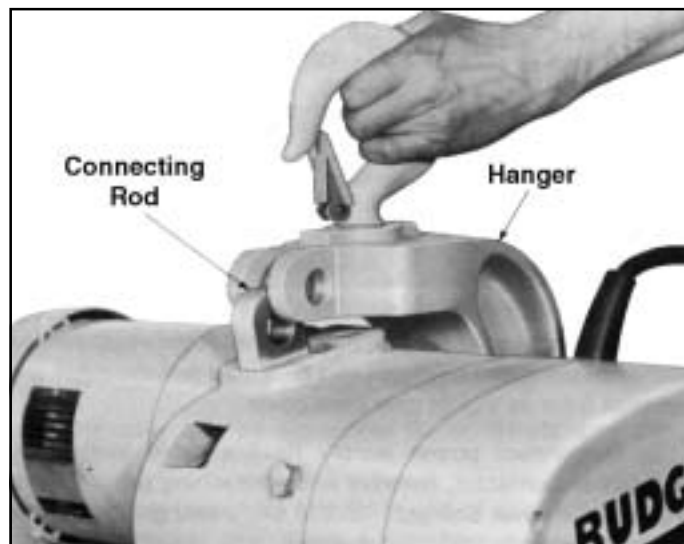

Figure 7-2. Ton Hanger Bracket Connection Pin Removed



Figure 7-3. Removing 3 Ton Hanger Bracket from Hoist Frame

To remove connecting link from chain, take out cotter key and push anchor pin from connecting link. Chain can now be pulled thru hanger bracket and lower block. Unfasten tail chain from hoist frame, remove limit actuator, and if power is available, operate hoist in lowering direction to remove chain. (See note in Sec. V, par. 5-2. a. (3) for inserting short length of chain). If hoist is inoperative see note below but be sure to install short length of chain into hoist before removing load chain.

NOTE: If hoist is inoperative it will be necessary to remove load brake (par. c, below) so chain can be pulled thru the hoist by hand.

(4) To remove 3 ton hanger bracket from hoist, remove retaining ring and connecting rod pin (see fig. 7-2). Rotate hoist approximately 45° (see fig. 7-3) and hanger will slip free from hoist frame.

b. Removal of Electrical Compartment Cover, Electrical Controls and Gear Case Subassembly.

(1) Disconnect hoist from power source. Remove three cover retaining screws and lift off cover (fig. 9-1). Cover screws have retaining rings which hold them in cover. Use caution as some covers contain counterweights. Two speed hoists with a 2-1/4 horsepower motor have an externally mounted counterweight at the electrical compartment cover.

(2) Disconnect push button conductor cable leads at plug-in type connectors that can be pulled apart. Remove screw and washer securing strain reliever (fig. 9-8) and pull the cable and grommet from its slot in gear case cover.

(3) Disconnect power supply flexible cable leads from terminals of contactor. Remove screw attaching ground leads to gear case cover and pull flexible cable and grommet from slot in cover.

(4) Disconnect motor leads from electrical control units. Number of leads depends on type of motor. (See wiring diagrams in Section VIII).

(5) Remove eight hex socket head screws and lockwashers securing gear case cover to hoist frame. Pry gear case cover partially off hoist frame using screw driver at special notches provided at opposite corners of cover (fig. 7-4) to provide access for removing limit lever key from control shaft. Tilt Woodruff key in shaft slot using drift punch (fig. 7-5) and pull out using pliers. Gear case cover with electrical controls attached can now be lifted from frame (fig. 7-6). Limit lever will drop free of frame as shaft is removed with cover. Discard gear case cover gasket.

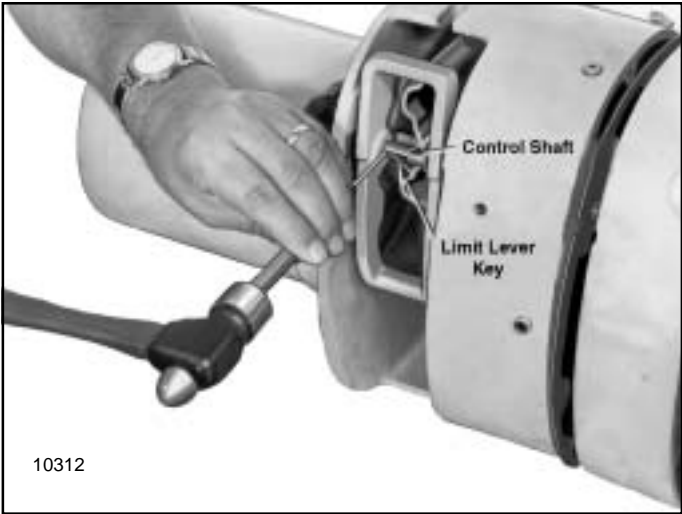

Figure 7-5. Removing Limit Lever Key from Control Shaft



Figure 7-6. Gear Case Cover with Electrical Controls Removed from Frame

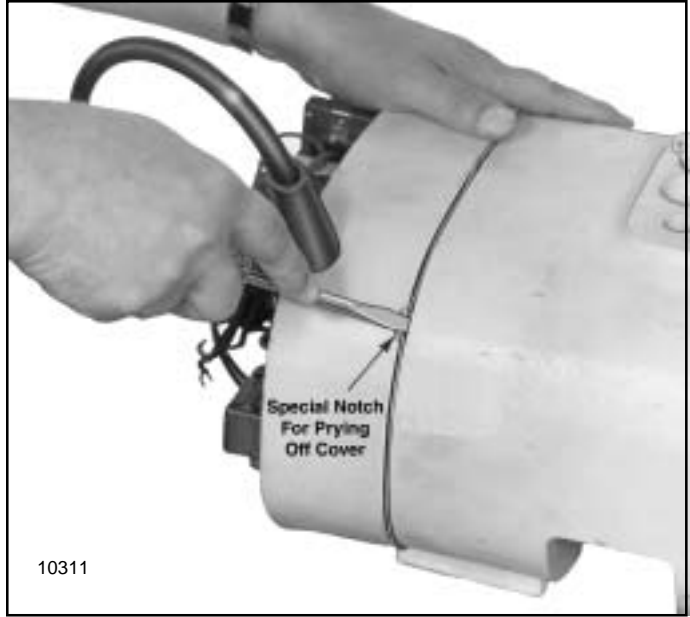

Figure 7-4. Prying Gear Case Cover from Hoist Frame

c. Removal of Load Brake and Clutch Assembly and Intermediate Gear Subassembly.

(1) On 1/4 thru 1/2 ton hoists, pull load brake and overload clutch assembly and the brake shaft washers from inside hoist frame (fig. 7-7). Caution: Grease-retained bearing has 36 rollers (all capacities) and may be reinstalled unless rollers are broken or missing or cup is damaged.

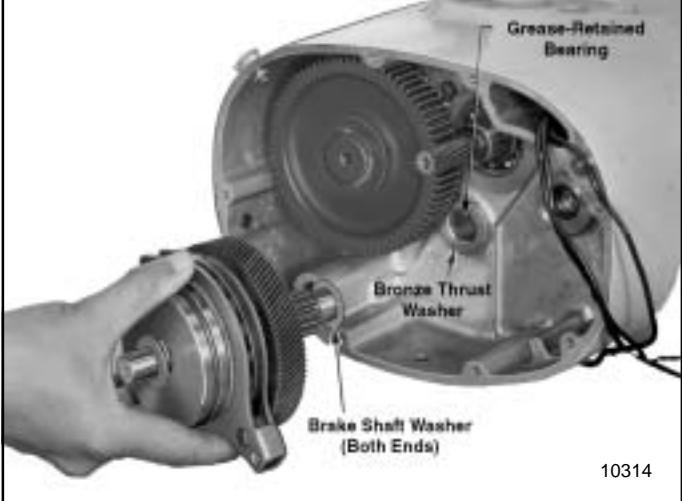

Figure 7-7. Removing Load Brake and Clutch Assembly (1/4 & 1/2 Ton Hoists)

(2) On 1 thru 3 ton hoists, pull load brake and clutch assembly and intermediate gear assembly, including the thrust washers for each unit, from hoist frame (fig. 7-8).

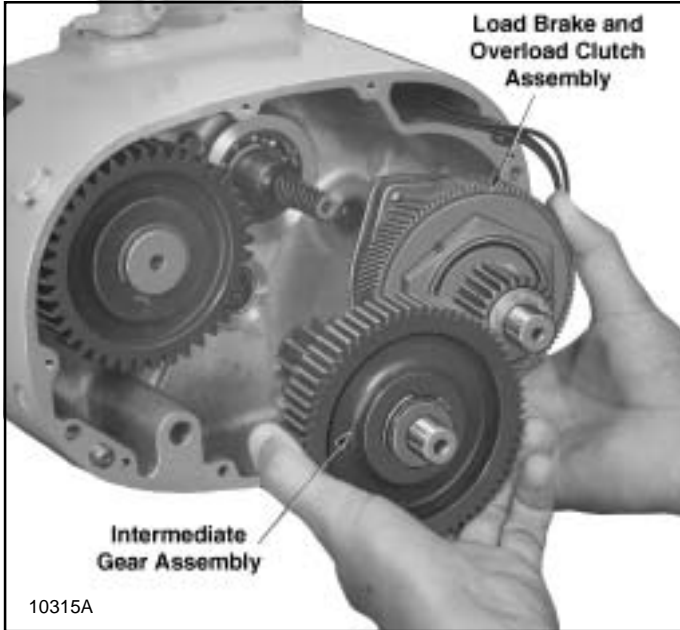

Figure 7-8. Removing Load Brake and Clutch and Intermediate Gear Subassemblies (1 thru 3 Ton Hoists)

d. Removal of Motor Brake.

(1) Remove acorn nuts holding brake cover and remove brake cover (fig. 9-16).

(2) Disconnect wire nuts on brake rectifier leads.

(3) Remove brake mounting plate screws (fig. 9-16) and lift brake assembly off to gain access to the motor mounting bolts.

e. Removal of Motor Assembly.

(1) Place hoist frame on wood blocks to protect integral gear on motor shaft. Loosen four motor mounting bolts and lift motor assembly from frame (fig. 7-9). Guide motor leads through wire passage to avoid damage.

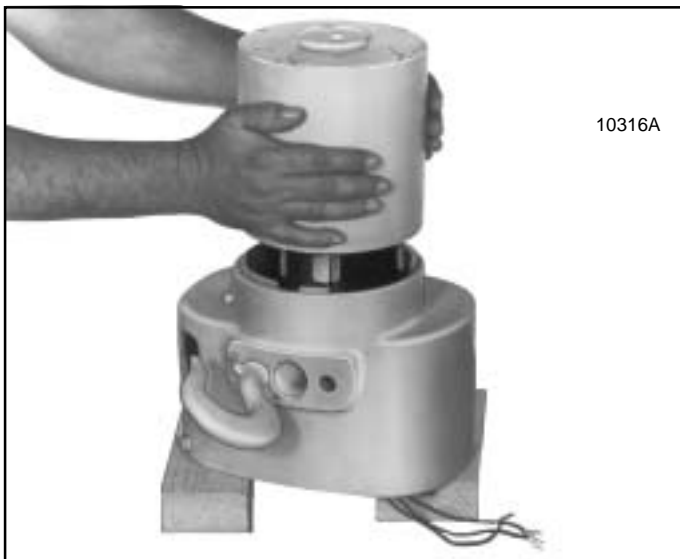

Figure 7-9. Removing Motor Assembly

7-3. REBUILD OF HOIST FRAME, SPROCKET GEAR, SPROCKET SHAFT AND CHAIN GUIDE.

a. Disassembly of Sprocket Gear, Shaft and Chain Guide.

(1) Remove retaining ring from end of sprocket shaft and pull off sprocket gear using a common puller (fig. 7-10). Remove Woodruff key from shaft.

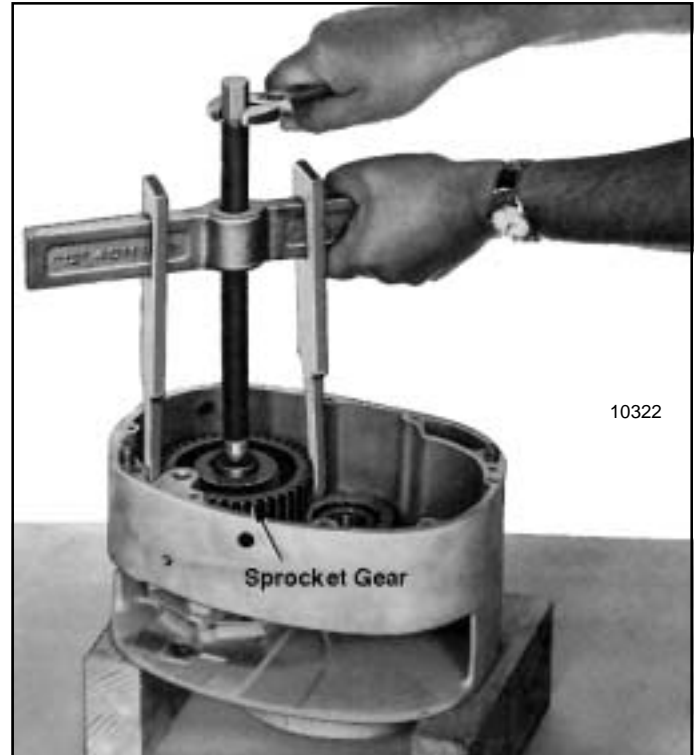

Figure 7-10. Pulling Sprocket Gear from Sprocket Shaft using Common Puller

(2) Unscrew four fillister head machine screws securing sprocket bearing retaining plate and remove plate (fig. 7-11). Remove and discard ring gasket from groove around bearing or remove seal disc (fig. 7-12).

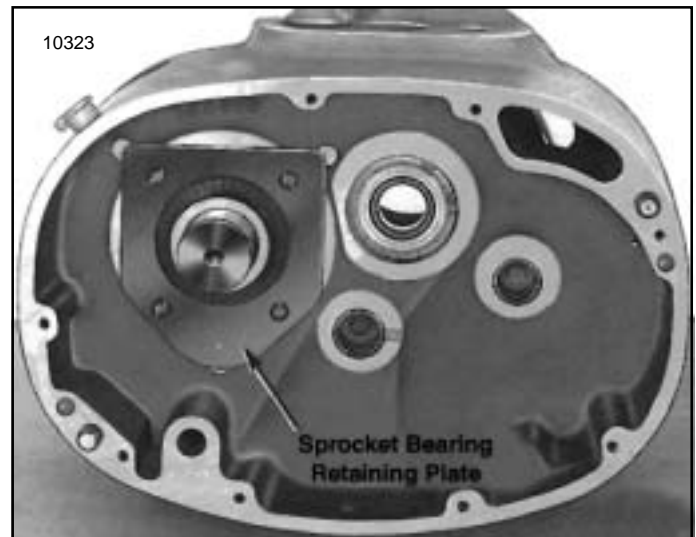

Figure 7-11. View of Sprocket Bearing Retaining Plate

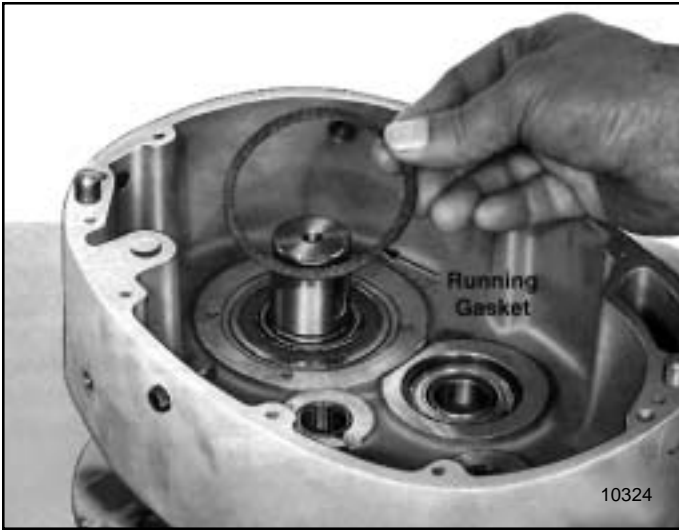

Figure 7-12. Removing Sprocket Bearing Ring Gasket.
(On later model hoists ring gasket is replaced by a seal disk with oil seals)

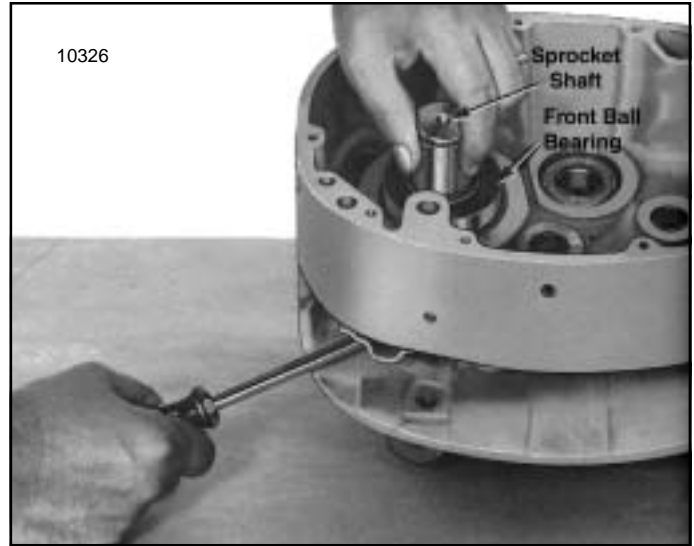

Figure 7-14. Removing Sprocket Shaft and Front Bearing

NOTE: Do not remove oil seal, ball bearings, and needle bearings from their bores in the frame unless they show evidence of wear or damage and require replacement. When replacing rear sprocket ball bearing pack bearing 1/2 full with NLGI No. 2 grease.

(3) Using suitable pry bar (fig. 7-13) partially raise two chain guide support pins from their bores in frame. Pull them the rest of the way out using pliers with jaws protected to avoid damaging pins. Remove and discard two "O" ring gaskets from grooves on each support pin.

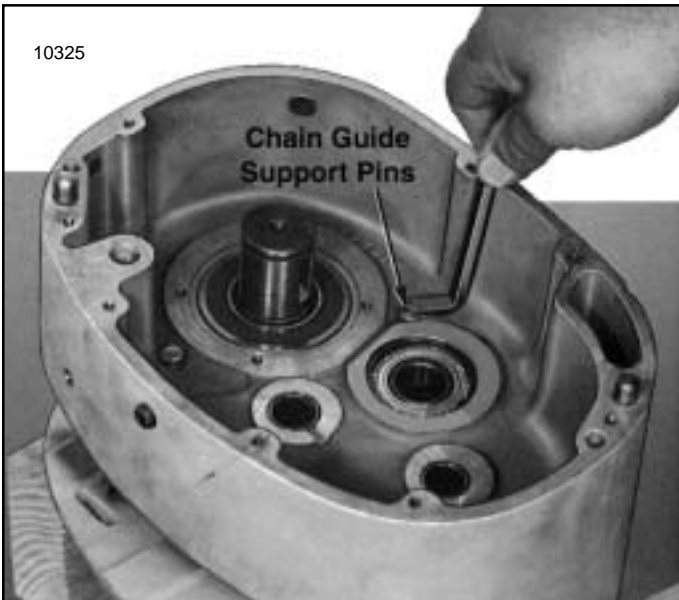

Figure 7-13. Removing Chain Guide Support Pins using Pry Bar

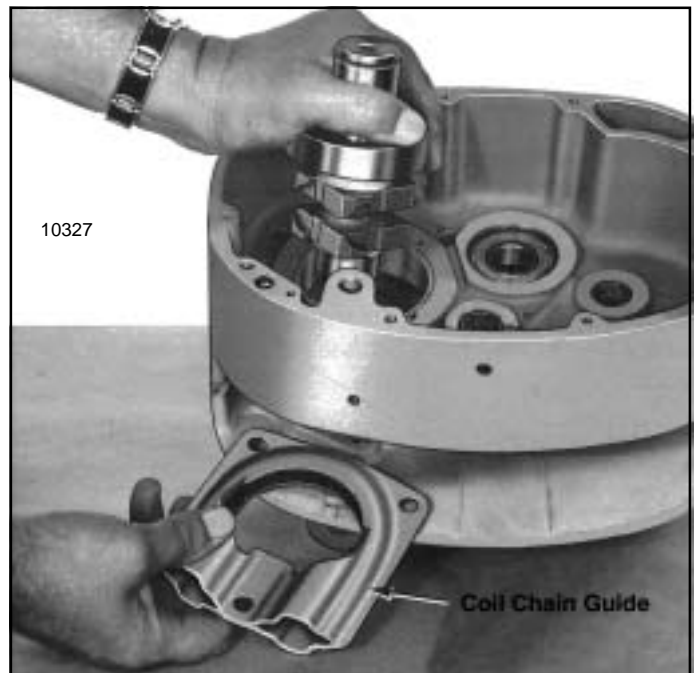

Figure 7-15. Chain Guide Being Removed from Frame as Sprocket Shaft is Lifted Out (Link Chain Models)

(4) Remove sprocket shaft and front ball bearings assembly from frame by lifting up on end of shaft while prying up on sprocket as illustrated in figure 7-14. The chain guide will need to be repositioned in frame as sprocket shaft is raised to allow the sprocket to pass thru hole of guide (fig. 7-15). On roller chain model hoists, the chain stripper must be partly removed from guide by prying it out using screw driver or other suitable tool. See figures 7-16 and 7-17.

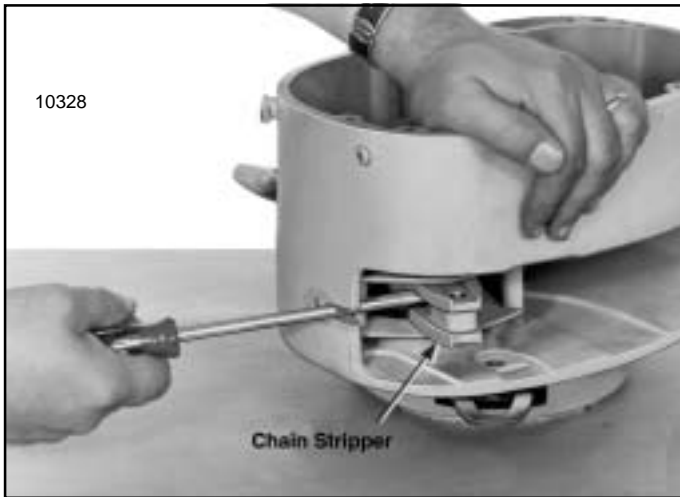

Figure 7-16. Chain Stripper being partially removed from Chain Guide (Roller Chain Model)

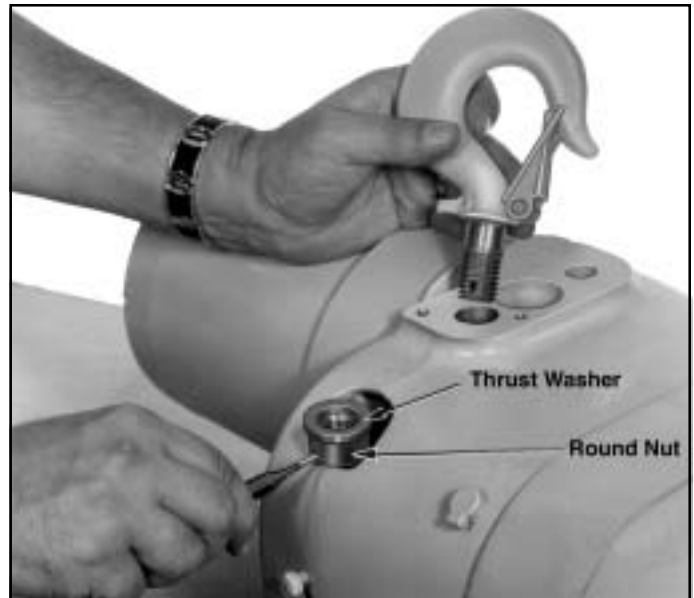

Figure 7-18. Removing Upper Hook and Hook Nut from Hoist Frame (1/4 thru 1 Ton Models)

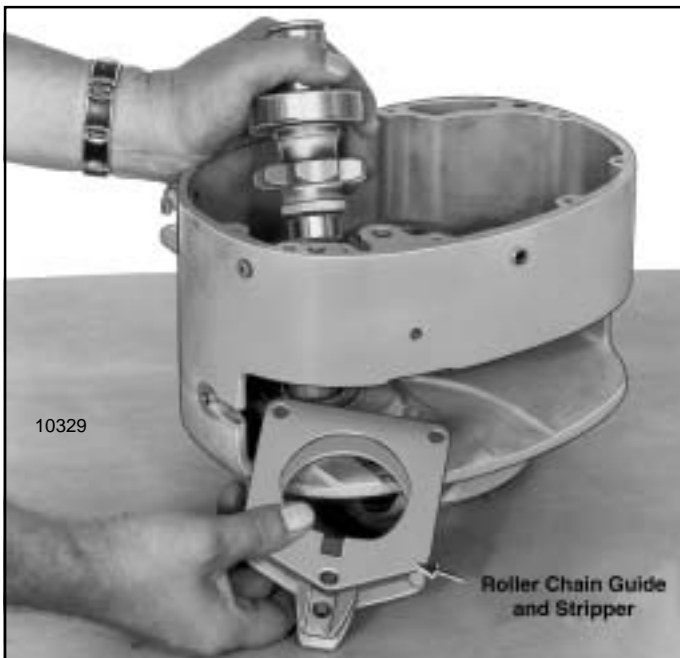

Figure 7-17. Chain Guide and Stripper being removed from Frame as Sprocket Shaft is lifted out (Roller Chain Model)

b. Disassembly of Upper Hook. (Hook Suspension Models)

(1) On 1/4 thru 1 ton models, drive pin from hook nut using drift punch and unscrew upper hook. Nut is reached thru access hole in side of hoist frame. See figure 7-18.

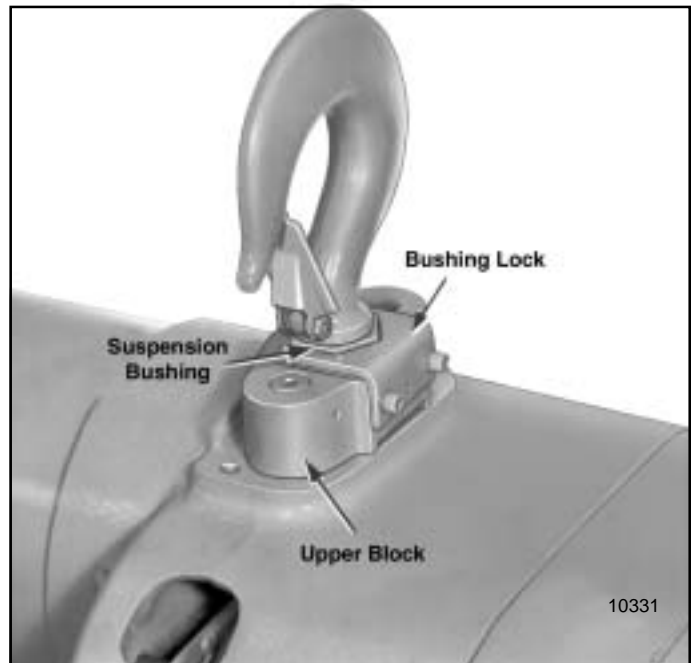

Figure 7-19. View of Upper Hook Assembled to Hoist Frame (2 Ton Models)

NOTE: Hook and bushing assembly is not to be further disassembled as nut securing bushing to hook shank is welded in place at the factory. Only the assembly is available for replacement.

(3) On 3 ton models, remove retaining ring from connecting rod pin and push connecting rod pin through bracket and connecting rod, releasing hanger (see fig. 7-2). Raise hanger above hoist frame to provide access to hook nut. Rotate hook until grooved pin in nut is visible from end of hanger frame. Using a drift punch, drive grooved pin thru hook nut until it hits hanger pocket. Remove drift far enough to hold nut from turning and unscrew hook from nut. Thrust washer will fall free.

(4) To remove connecting rod (fig. 7-2) on 3 ton hoist, drive pin from rod nut using drift punch and unscrew connecting rod. Nut is reached thru access hole in side of hoist frame. (See fig. 7-18).



Figure 7-20. Removing Suspension Lug (1/4 thru 1 Ton Models)

c. Disassembly of Suspension Lug (Lug Suspension Models).

(1) On 1/4 thru 1 ton models drive grooved pin from the round nut inside the hoist frame. Hold round nut from rotating with drift punch thru access hole in side of hoist frame. Unscrew suspension stud assembly by wrenching hex on top of suspension lug (see fig. 7-20).

(2) On 2 ton models, remove three hex socket head screws securing the two lock plates to block at top of frame and pull out locks. Remove suspension lug, using an extra thin 1-1/4" open end wrench to unscrew suspension bushing from block. Instructions for removing block from frame are given in paragraph b. (2).

NOTE: The suspension lug is not to be further disassembled, as nut securing suspension bolt and bushing to lug is permanently secured in place at the factory. Only the suspension lug assembly is available for replacement.

(3) On 3 ton models lug bolt is removed in same manner as hook. See paragraph 7-3. b. (3).

d. Reassembly.

(1) Before assembly, all parts should be thoroughly cleaned and inspected to determine their serviceability. Replace parts that are excessively worn or damaged.

(2) Reassemble suspension hook or lug, chain guide, sprocket shaft and sprocket gear to frame following a reverse procedure of the disassembly steps listed in paragraphs (a.) thru (c.), above. If ball bearing is to be reinstalled on sprocket be certain to position it so that the seal side of bearing faces out, away from sprocket. To help prevent oil seepage, apply sealant on O.D. of sprocket bearing and in seat for the ring gasket.

7-4. REBUILD OF LOAD BRAKE AND OVERLOAD CLUTCH ASSEMBLY.

a. Disassembly.

(1) Place load brake and clutch assembly, flange up, in a vise equipped with brass or copper jaw plates to protect pinion gear teeth. Remove snap ring of load brake shaft (fig. 7-21).



Figure 7-21. Removing Snap Ring from Load Brake Shaft

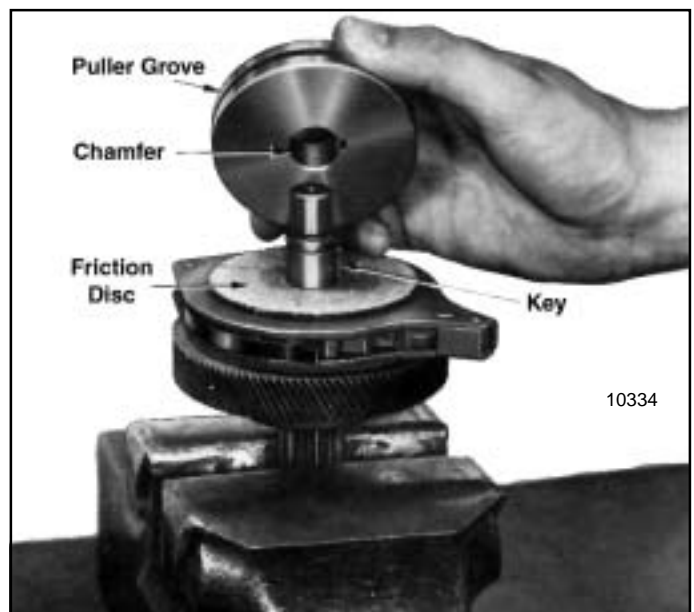

Figure 7-22. View Showing Load Brake Flange Removed

(2) Using a puller tool, remove brake flange from shaft. A groove is provided around outer diameter for this purpose. See figure 7-22. Remove key from shaft and lift off 2 friction discs, and the pawl and ratchet assembly (fig. 7-23).

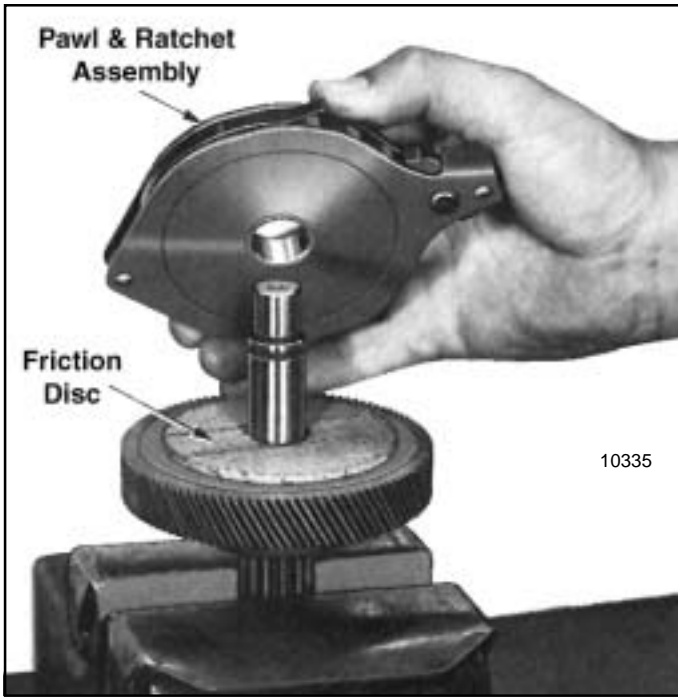

Figure 7-23. Removing Pawl and Ratchet Assembly from Load Brake Shaft

(3) Remove load brake gear and overload clutch assembly from output pinion shaft. Pull the spring from its recess in clutch cone (fig. 7-24) but do not further disassemble gear and clutch assembly. See "NOTE" below.

NOTE: Disassembly of the load brake gear and overload clutch assembly (fig. 7-24) is not recommended. Clutch pressure is preset by the factory at assembly to provide the correct torque to allow the clutch to refuse loads within a specified range (110% of rated load to 180% rated load). It is suggested whenever there is a need to repair or readjust the gear and clutch assembly that it be sent to an authorized **Budgit** Hoist Repair Station where adequate tools, fixtures and appropriate test equipment is available.

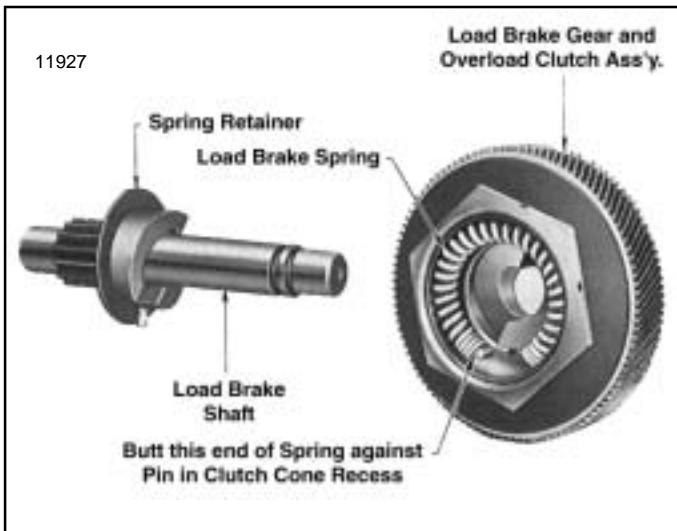

Figure 7-24. Load Brake Gear and Overload Clutch Assembly Removed from Load Brake Shaft Showing Brake Spring Installed in Clutch Cone

(4) The load brake pawl and ratchet is a riveted assembly and is not to be disassembled.

b. Reassembly.

(1) Before assembly, all parts should be cleaned and inspected to determine their serviceability. Replace parts that are excessively worn or damaged.

(2) Reassemble load brake parts following a reverse procedure of the disassembly steps listed above, observing the assembly steps (3) thru (6) below.

(3) Before installing spring in its recess in center of clutch cone (fig. 7-24) apply a good grade of ball bearing grease to inside of recess. Spring must be positioned exactly as illustrated, abutted against pin.

(4) When installing pawl and ratchet assembly on load brake shaft, be certain that teeth on ratchet face are in the same direction as shown in fig. 7-23. The ratchet assembly should rotate freely when turned counterclockwise and the pawl should engage ratchet teeth when unit is turned clockwise.

(5) When installing brake flange position it with chamfer facing friction disc, figure 7-22.

(6) The brake spring must be pre-loaded at assembly to a torque of from 6 to 10 lb. ft. when used with yellow (color code) spring and a torque of 10 to 14 lb. ft. when used with plain (no color code) spring. (See Section IX for proper spring). This is accomplished using a plumber's strap wrench to wind (rotate) load brake gear to set up spring (fig. 7-25) while pressing brake flange into place using an arbor press. Clamp pinion end of shaft into a portable vice to keep brake from rotating in press. Use brass or copper jaw plates on vise to protect pinion gear teeth. Wind gear counterclockwise (viewing brake from flange end) with strap wrench and press down on flange until snap ring groove in shaft is exposed allowing snap ring to be installed. Use extreme care not to over wind spring as yield will result and final spring torque will be reduced. Do not wind gear beyond point necessary to install snap ring in groove.

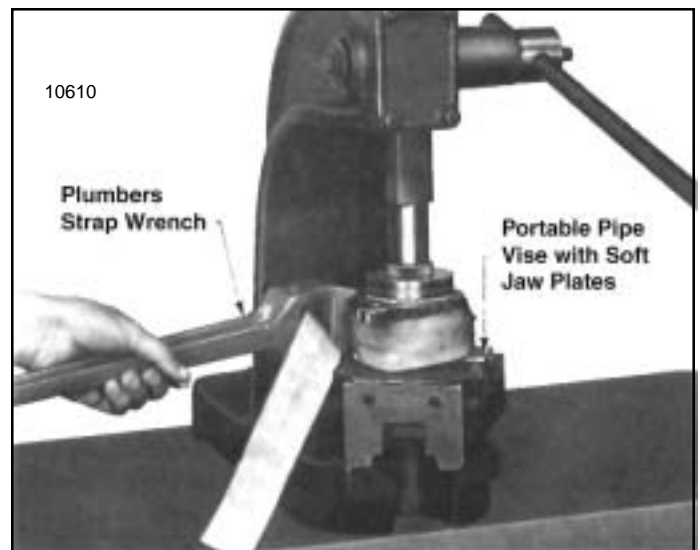

Figure 7-25. Winding Load Brake Gear Using a Strap Wrench to Set Up Load Brake Spring

7-5. REBUILD OF LOWER BLOCK AND LOAD CHAIN ASSEMBLY.

a. Disassembly (1/4 through 1-ton, single reeved models).

(1) Separate load chain (link or roller type) from lower block assembly. Drive out small roll pin securing lower block pin in lower block yoke and push lower block pin from yoke to release chain. On roller chain models, an adapter is used to attach chain to lower block. This adapter is removed from end of chain by first driving out small roll pin and then pushing out adapter pin.

(2) Drive grooved pin from limit actuator and pull actuator from end of chain.

(3) Lower blocks are of a pinned construction, permitting replacement of body, thrust bearing, or hook and nut assembly. To disassemble, drive spring pin from hook nut (fig. 7-26). With pin removed, hold hook nut from turning with drift punch and rotate hook to unscrew it from nut.



Figure 7-26. Removing Roll Pin Securing Hook Nut to Hook Shank

Separate hook, bearing shield, needle bearings and two thrust washers from body. Hook and nut are drilled at assembly and are replaced only as an assembly.

b. Disassembly (2-ton, double reeved models).

(1) On 2-ton roller chain models, remove retaining ring from one end of sprocket pin and press pin from lower block body. Grasp chain and pull out sprocket and two spring washers from body. Do not remove needle bearing from sprocket or pressure lube fitting from sprocket pin unless replacement is necessary.

(2) On 2-ton link chain models, remove fillister head screw securing center guide in top of lower block body and lift out guide (fig. 7-27) and sprocket pin lock (fig. 7-28). Press sprocket pin from body and pull out chain, sprocket and washer (fig. 7-29). Do not remove bushing type bearing from sprocket or pressure lube fitting from sprocket pin unless replacement is necessary.

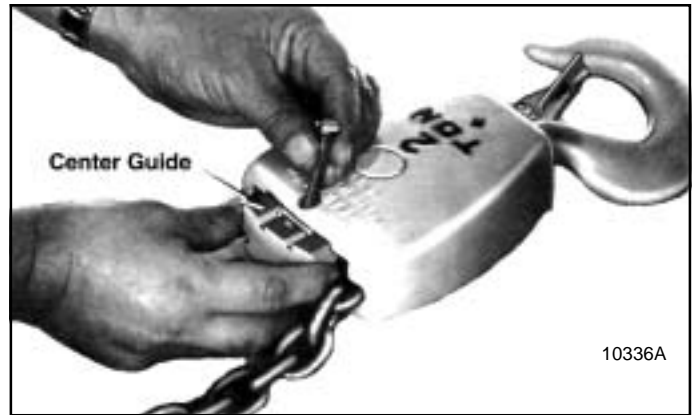

Figure 7-27. Removing Chain Center Guide from 2 thru 5 Ton Lower Block Assembly (Link Chain Model)



Figure 7-28. Removing Sprocket Pin Lock on 2 thru 5 Ton Lower Block Assembly (Link Chain Model)



Figure 7-29. Removing Coil Chain and Sprocket on 2 thru 5 Ton Lower Block Assembly (Link Chain Model)

(3) To disassemble hook and nut, drive groove pin from hook nut with drift punch. With pin removed, hold hook nut from turning with drift punch and rotate hook to unscrew it from nut. Separate hook, nut, bearing shield, needle bearing and two thrust washers from body. Hook and nut are drilled at assembly and are replaced only as an assembly.

c. Disassembly (3-ton, triple reeved models).

(1) Remove chain sprocket from lower block following procedure for 2-ton link chain models described in paragraph 7-5. b. (2) above.

(2) To disconnect end of chain anchored to lower block, remove retaining ring from pin bore (fig. 7-30). Push connecting link pin from bore by pressing through hole provided in opposite side of block (fig. 7-31). Chain connecting link is now free and can be further disassembled for inspection.

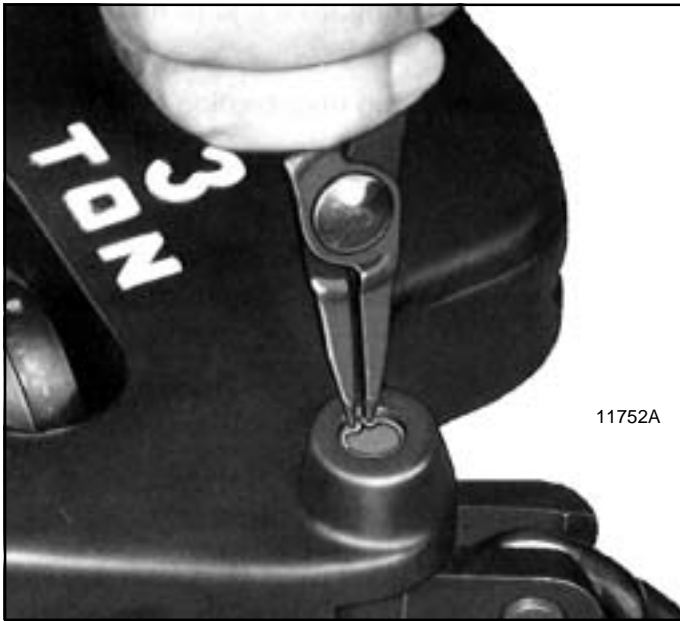

Figure 7-30. Removing Retaining Ring from Bore of Connecting Link Pin - 3 Ton Lower Block Assembly

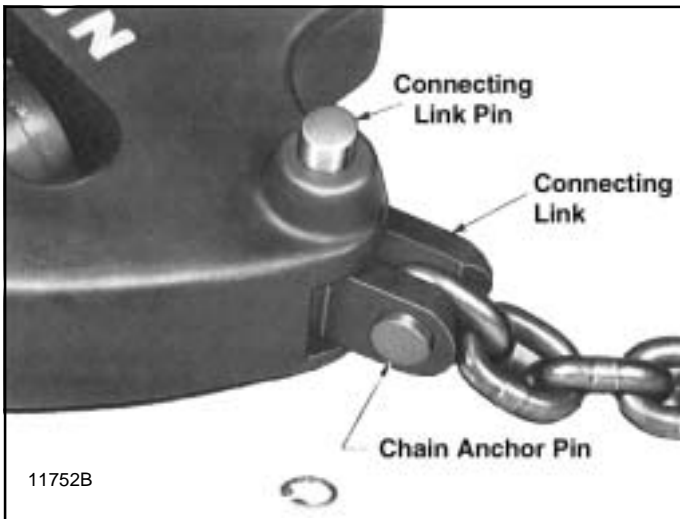

Figure 7-31. Removing Connecting Link Pin from 3 Ton Lower Block Assembly

(3) To remove hook from lower block body, first drive grooved pin from hook nut. Then hold nut from turning using drift punch and rotate hook to unscrew it from nut. Separate hook, shroud and thrust washer from body. Note that bearing surface of washer faces nut.

(4) To remove chain sprocket from upper suspension hanger, first remove hanger as outlined in paragraph 7-2. a. (4). With hanger removed, push sprocket pin from hanger and sprocket. **NOTE:** Sprocket pin must be removed toward side having small anti-rotation pin slot in hanger.

d. Reassembly of Lower Blocks.

(1) Clean, inspect and replace worn or damaged parts.

(2) Lubricate and reassemble following a reverse procedure of the disassembly steps above.

7-6. REBUILD OF ELECTRICAL CONTROLS AND GEAR CASE COVER SUBASSEMBLY.

a. Disassembly.

(1) Disconnect two limit switch leads from contactor. Also, if hoist has a transformer, disconnect transformer leads at the contactor or terminal board.

(2) Remove reconnectable terminal board if so equipped.

(3) Remove two screws and lift transformer from gear case cover if hoist is so equipped.

(4) Remove two screws attaching contactor assembly to cover and lift off contactor. Refer to paragraph 7-8 for instructions for rebuild of contactor assembly.

(5) Remove two hex socket head screws and lockwashers securing limit switch assembly to gear case cover and pull limit switch assembly and control shaft from cover.

(6) Loosen two nuts and screws holding limit switches to retainer bracket and remove.

(7) Remove self-locking nut from end of control shaft and pull off washer, switch activator, centering lever, spring, spacer tube, retainer bracket and washer.

NOTE: Do not remove needle bearings from gear case cover unless they show evidence of wear or damage and require replacement.

b. Reassembly.

(1) Before assembly, all parts should be thoroughly cleaned and inspected to determine their serviceability. Replace parts that are worn or damaged.

(2) Reassemble parts to gear case cover in reverse of the disassembly steps above. Ends of centering spring must straddle centering levers. Lubricate contact segments of limit switch with small amount of graphite grease.

7-7. REBUILD OF PUSH BUTTON STATION AND CONDUCTOR CABLE ASSEMBLY.

a. Disassembly.

(1) Remove seven pan head machine screws and lockwashers from back of push button station and lift off rear cover.

(2) Loosen three terminal screws and remove strain cable screw, lockwasher and plain washer.

(3) Remove two pan head machine screws and lockwashers from housing cap and remove cap, grommet and cable assembly.

(4) Remove two pan head screws, contact assembly and button assembly.

b. Reassembly.

(1) Before assembly, all parts should be thoroughly cleaned and inspected to determine their serviceability. Replace all parts that are worn or damaged.

(2) Reassemble push button station and conductor cable following a reverse procedure of the disassembly steps listed above.

NOTE: Do not attempt to shorten or lengthen push button conductor cable. Odd length conductor cable assemblies for other than standard 10 ft. lift hoists can be procured from the factory.

7-8. REBUILD OF CONTACTOR ASSEMBLY.

a. General. Wear or damage to contractor parts requires replacement of complete contactor assembly.

7-9. REBUILD OF SINGLE PHASE MOTOR ASSEMBLY.

a. Disassembly.

(1) To inspect capacitor, remove two cover mounting screws and lift off capacitor cover. Do not disconnect wires at capacitor unless capacitor must be replaced.

(2) Remove external retaining ring from end of shaft and press shaft out of bearing in end bell.

(3) Remove motor end bell from stator assembly. If necessary loosen it by tapping with soft mallet.

(4) Remove internal retaining ring from bearing bore in end bell and press out bearing assembly.

b. Reassembly.

(1) Before assembly, all parts should be cleaned and inspected to determine their serviceability. Replace all parts that are worn or damaged.

(2) Reassemble motor following a reverse procedure of the disassembly steps listed above.

(3) After reinstalling hoist motor, connect hoist to power supply and carefully complete both checks (a) and (b) below:

(a) To check direction of rotation, briefly operate "↑" button. If hook lowers, interchange motor lead "T1" with "T4" at the contactor or controller. Hook must raise when the "↑" push button is operated.

(b) To check the starting winding switch, connect ammeter (minimum 10 ampere) to motor lead "T5". Amperes must drop to zero in approximately one second when operating hoist in both "↑" and "↓" directions. If ampere reading does not drop to zero, interchange motor leads "T7" and "T8". If, after above checks were made with motor having been run in both directions, the ammeter reading still does not return to zero, the motor switch is not functioning properly and should be replaced.

 WARNING
Do not change circuit wiring. Severe damage and malfunction of hoist may result.

7-10. REBUILD OF THREE PHASE MOTOR ASSEMBLY.

a. Disassembly.

(1) Pull four motor mounting bolts from motor and separate stator assembly from the end bell and rotor shaft assembly.

(2) Remove external retaining ring from end of motor shaft and press shaft from bearing in end bell.

(3) Remove internal retaining ring from bearing bore in end bell and press out bearing assembly.

b. Reassembly.

(1) Before assembly, all parts should be cleaned and inspected to determine their serviceability. Replace all parts that are worn or damaged.

(2) Reassemble motor following a reverse procedure of the disassembly steps listed above.

7-11. REASSEMBLY OF HOIST FROM SUBASSEMBLIES.

a. General. The procedure to be followed to reassemble the hoist from subassemblies is in reverse order of the disassembly steps outlined in paragraph 7-2. Listed below are special assembly precautions which should be observed to assure proper assembly.

NOTE: Grease retained bearings (see Section VII, par. 7-2. c. (1) and fig. 7-7) have loose rollers. When reassembling hoist, make certain the correct number of rollers are held in roller cup with grease before assembling load brake shaft to hoist.

b. Assembly of Load Brake Thrust Washers. When reinstalling load brake assembly be certain thrust washers are properly installed at both ends of load brake shaft, as noted below.

(1) A bronze thrust washer with a lug on one side belongs on pinion end of shaft and must be installed so that its lug engages the special slot located on spotface surrounding bearing bore inside hoist frame or gearcase cover. Use heavy grease to hold washer in proper position in frame or cover (depending upon hoist capacity) during assembly.

(2) On hoists with Catalog Number prefix letters "A," "C," "D," "L" an 11/16" I.D. plain steel thrust washer must be used between end of pinion gear and the bronze thrust washer (fig. 7-7).

(3) A 5/8" I.D. steel thrust washer is to be installed on the brake flange end (end opposite pinion) of load brake assembly.

c. Motor Brake. Instructions for adjusting the brake are inside the brake cover and are repeated below. Check brake adjustment after first 30 days of service and regularly thereafter during the six-month inspection procedure.

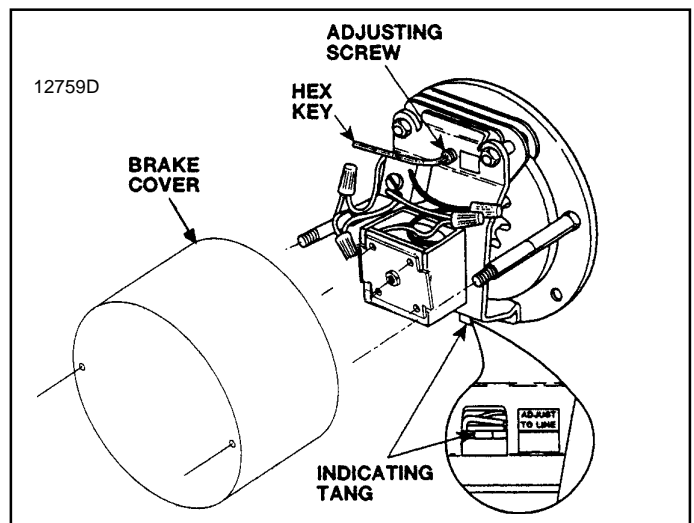

Figure 7-32. Hoist Motor Brake

(1) Examine position of indication tang located below the solenoid coil (see figure 7-32).

(2) If the tang is below the line by more than 1/8", the brake should be adjusted to bring the top of the tang back up alongside the line on the adjust label.

(3) Removing the hex key (1/8" size) from the holster on the cover mounting stud and carefully turn the ADJUSTING SCREW (located above the solenoid coil) clockwise. The indicating tang will move a large distance for a small turn of the adjusting screw, therefore turn the screw no more than one-quarter turn before checking adjustment.

(4) After adjustment operate the brake by hand to assure brake disc running clearance. The outboard brake pad should separate from the brake disc by approximately .010".

(5) Air gap adjustment.

(a) Loosen jam nut using 7/16" wrench while holding set screw with 1/8" hex key.

(b) Pull brake release lever as far as possible away from motor, and hold.

(c) Turn in set screw until it contacts plunger (when movement is felt in release lever), then turn in 1/4 to 1/2 additional turn.

(d) Tighten jam nut, making sure set screw does not turn.

(e) Test operation of brake.

(f) Readjust as necessary, 1/4 to 1/2 turn at a time, until brake sets properly.

(6) Replace hex key in holster.

(7) Replace brake cover.

(1) Brake Adjustment. Adjust brake if clearance between pressure pad and brake disc is more than .040" (see fig. 7-32) or if brake is drifting.

(2) Tools Required.

(a) Feeler gage (.020" to .040") or equivalent.

(b) Hex key (1/8" size).

(3) To Adjust Brake.

(a) Minimum clearance between pressure pad and brake disc is .020" to .025" (see fig. 7-32). Set feeler gage between .020" and .025" and place between pressure pad and brake disc. Use 1/8" hex key on adjusting screw (located above solenoid coil). Stop turning adjusting screw when contact is made with the pressure pad. Remove feeler gage.

(b) After adjustment operate brake by hand to assure brake disc running clearance. The outboard pressure pad should separate from the brake disc by approximately .010" to .013".

(4) Replace brake cover.

d. Assembly of Load Chain.

NOTE: Link chain must be installed so welds on vertical links face away from the load sprocket.

(1) On link chain and roller chain models install load chain over sprocket before load brake assembly is installed. Insert anchor end of chain (end opposite lower block on single reeved models) into chain guide opening on far side of hoist (viewing frame from anchor screw side). Rotate sprocket gear by hand

counterclockwise as chain is fed into opening. When sufficient chain has been run into hoist to reach anchor position, plus a slack loop, install limit actuator on anchor end of load chain (see (3) below) and attach end of chain to frame with special fillister head screw. Be certain chain is not twisted.

(2) On roller chain models, the chain may be installed after step (e) below is accomplished, allowing chain to be run into hoist under power. Caution must be exercised so that fingers or hands are not caught in chain while it is being fed into hoist.

NOTE: The spring clip connecting link must be attached to anchor end of roller load chain before chain is run into hoist. Failure to do so may result in damage to chain or hoist.

(3) When installing limit actuator on anchor end of load chain attach it at link shown below using a grooved pin. See Figure 3-2.

Type Chain	Size Chain	Number of Chain Links From End Link
Link	1/4" Wire Dia.	8 Links
Link	5/16" Wire Dia.	8 Links
Roller	5/8" Pitch	8 Links
Roller	3/4" Pitch	7 Links

e. **Wiring Hook-Up.** Before installing hoist, connect wiring to electrical controls in accordance with applicable wiring diagram. Wires are coded and/or numbered to agree with wiring diagrams.

f. Lubricate Hoist. Lubricate hoist as outlined in Section IV.

7-12. TESTING HOIST.

a. **General.** After completion of reassembly and before placing hoist in service, hoist should be tested to insure safe operation. To test: suspend hoist from an overhead supporting member of sufficient strength to carry rated load; connect to a power supply of the specified voltage (see data plate attached to motor); and perform the following checks and adjustments.

b. **Check For Correct Control Operation.** Refer to Section II, par. 2-4. d, under "Warning."

c. **Check Upper and Lower Limit Stop Operation.** To determine if upper and lower limit stop functions properly, make the following checks while operating hoist with push button control and actuating the limit lever by hand:

(1) Depress "↑" push button and with chain running in raise direction, pull down on end of limit lever at tail chain side of hoist (left side facing cover end). The "UP" limit switch should cut off power, causing the hoist to stop.

(2) Depress "↓" push button and with chain running in lowering direction, push up on same end of limit lever. The "DOWN" limit switch should cut off power, causing the hoist to stop.

(3) If hoist does not stop in both travel directions, check for improper wiring. Refer to par. 6-2 and appropriate wiring diagram. If wiring is correct, check to see that limit switch is correctly installed.

(4) As a final check, operate hoist (no load) in the lowering direction and allow tail chain limit actuator to trip limit lever.

Hook should stop. Repeat check in hoisting direction and allow lower block to trip limit lever. Hook should stop.

d. **Check Hoist With Rated Load.** Attach rated load to lower hook and check hoist operation. If hoist does not lift rated load, refer to par. 7-13.

(1) Operate hoist to raise load. When control is released, load hoist should instantaneously stop and hold load at that level.

(2) Operate hoist to lower load a short distance, then release control. Hoist should stop instantaneously and hold load at that level.

(3) If hoist does not stop or hold load refer to Section VI.

7-13. TEST PROCEDURE FOR CHECKING OPERATION OF OVERLOAD CLUTCH.

a. **General.** The overload clutch must be tested using known weights. The following prerequisites (par. (1) thru (4)) must be strictly observed in performing this test.

(1) A qualified person shall determine before testing, that all structures supporting the hoist are adequately strong to withstand the test load of 200 percent of rated hoist load, whether hoist is tested in installed position or moved to a designated test facility.

(2) Loads used for testing must be accurately known.

(3) Test shall be made only by a qualified operator thoroughly familiar with the hoist and the purpose of the test.

(4) Provide adequate and proper rigging to insure test loads are securely attached, properly balanced, and will lift level.

b. **Test Procedure.** With the above prerequisites satisfied and hoist properly connected to electrical power, proceed with the test as follows:

(1) Using a known load equal to rated load of hoist, operate hoist to lift load. Raise load high enough to be certain the entire load is freely suspended. **Clutch should not slip at rated load.** If hoist does not lift rated load, clutch requires adjustment. Refer to Section V, par. 5-4. c.

(2) Increase load to 200 percent rated load and operate hoist to lift the load. **Clutch must slip**, causing the hoist to refuse to lift the load. If hoist lifts this overload, the overload clutch is out-of-adjustment and must be readjusted. Refer to Section V, par. 5-4. c.

(3) If clutch slips as required in step (2) above, continue to run hoist (clutch slipping-hoist refusing to lift load) for five (5) cycles of one (1) second each.

(4) Remove excess weight to return the load to rated hoist load. Lift rated load one final time to be certain that the clutch does not slip and that the hoist lifts the rated load.

WARNING

DO NOT LIFT MORE THAN RATED LOAD EXCEPT FOR TEST PURPOSES

NOTICE

THIS EQUIPMENT MUST BE EFFECTIVELY GROUNDED ACCORDING TO THE NATIONAL ELECTRIC CODE, ARTICLES 250-57, 250-59, OR 610-61 OR OTHER APPLICABLE CODES. IF THE GROUNDING METHOD USED IS THROUGH THE TROLLEY WHEELS, THEN EACH SECTION OF THE TRACK MUST BE GROUNDED BY METAL-TO-METAL CONNECTION TO THE BUILDING GROUND OR ELECTRICAL SYSTEM GROUND.

SECTION IX - REPLACEMENT PARTS

This section contains complete replacement parts information for your new **Budgit** Electric Hoist. The parts are grouped and illustrated in exploded view photos to permit easy identification. Each part in an illustration is keyed by reference number to a corresponding parts table. In the table will be found the BH part number, description and quantity required.

When ordering replacement parts it will be necessary that you include, with your order, the BH part number of parts required, plus, hoist catalog number and model number, which will be found on the hoist nameplate attached to motor. For motors complete motor nameplate data is required. Complete inspection, maintenance and overhaul service is available for **Budgit** Electric Hoists at any of the Authorized Repair Stations. All are staffed by qualified factory-trained servicemen; have

authorized testing equipment; and stock a complete inventory of genuine replacement parts.

NOTICE: Information herein is subject to change without notice. Parts must be ordered from an Authorized **Budgit** Repair Station or from a **Budgit** Hoist Distributor.

The numbers assigned to the parts of our various assemblies in our parts lists are not the part numbers used in manufacturing the part. They are identification numbers, that when given with the hoist serial number, permit us to identify, select or manufacture, and ship the correct part needed for any hoist.

INDEX OF EXPLODED VIEW PARTS ILLUSTRATIONS

Figure No.	Title	Page
9-1	Frame and External Parts	29-32
9-2	Upper Suspension, Load Chain and Lower Block Parts (2 ton Hoists)	33-34
9-3	Upper Suspension, Load Chain and Lower Block Parts (3 ton Hoists)	35-36
9-4	2 and 3 Ton Lower Block Assembly (Link Chain Hoists)	37
9-5	2 Ton Lower Block Assembly (Roller Chain Hoists)	38
9-6	Gearing and Load Brake Parts (1/4 and 1/2 Ton Hoists)	39-40
9-7	Gearing and Load Brake Parts (1 thru 3 Ton Hoists)	41-42
9-8A	Electrical Control Units (Three Phase Single Speed Hoists - Later Version)	43-44
9-8	Electrical Control Units (Three Phase Single Speed Hoists - Early Version)	45-46
9-9A	Electrical Control Units (Two Speed Hoists Only - Later Version)	47-48
9-9	Electrical Control Units (Two Speed Hoists Only - Early Version)	49-50
9-10A	Electrical Control Units (Single Phase Hoists - Later Version)	51-52
9-10	Electrical Control Units (Single Phase Hoists - Early Version)	53
9-11	Limit Lever and Switch Parts	54
9-12	Push Button Station and Conductor Cable Assembly (Single Speed Hoists)	55
9-13A	Push Button Station and Conductor Cable Assembly (Two Speed Hoists Only - Later Version)	57-58
9-13	Push Button Station and Conductor Cable Assembly (Two Speed Hoists Only - Early Version)	59-60
9-14A	Single Phase Motor Assembly - later Version	61
9-14	Single Phase Motor Assembly - Early Version	62
9-15	Three Phase Motor Assembly	63-64
9-16A	Hoist Motor Brake	65-66

To enable us to expedite your parts order, always give Model and Catalog Number and Electric Current of Hoist. (See nameplate.)

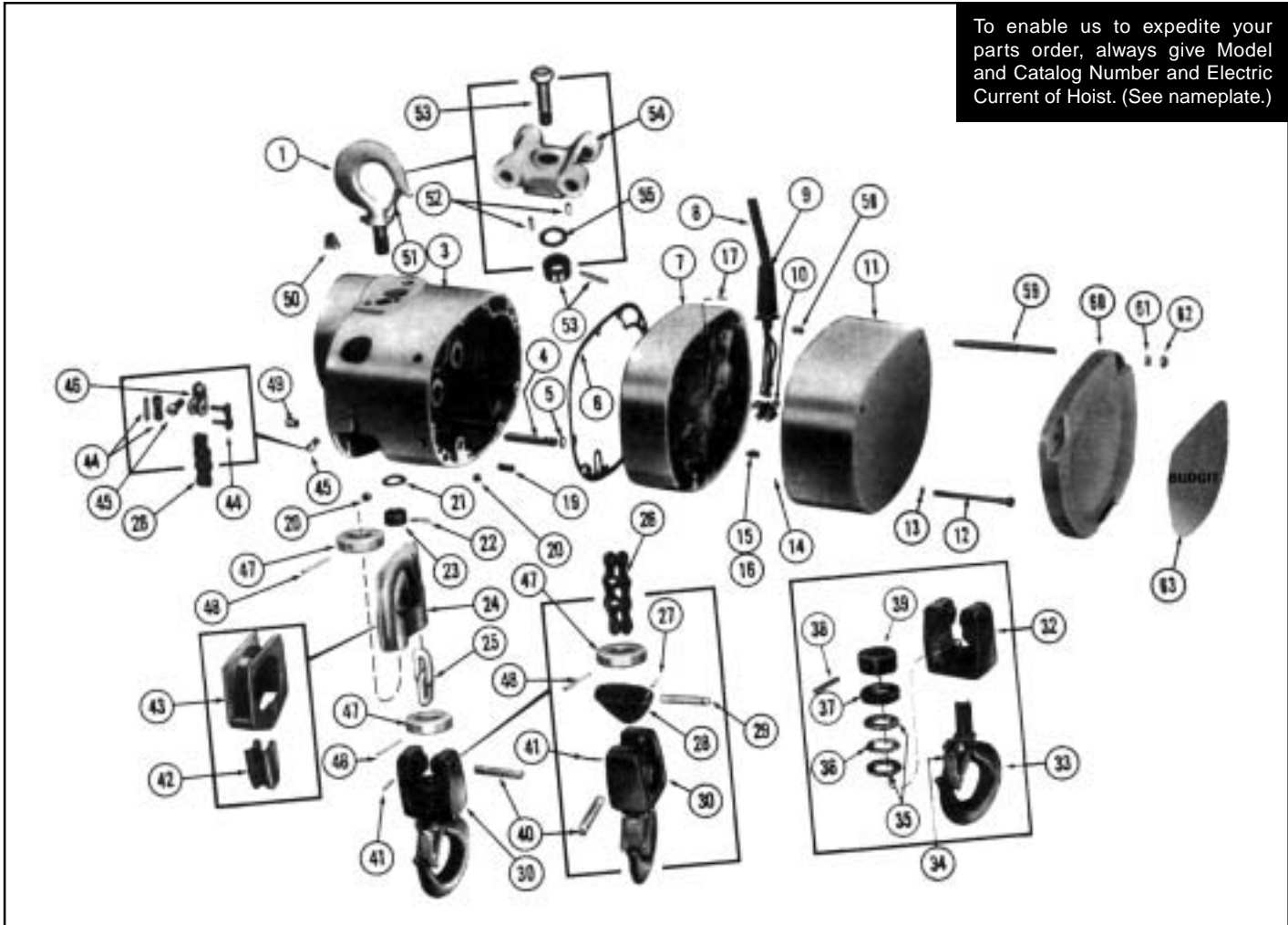

Figure 9-1. FRAME AND EXTERNAL PARTS
Standard and Plating Service Hoists
(Except 2 thru 3 Ton Model Upper Suspension, Load Chain and Lower Block)

Ref. No.	Part Number	Description	Qty. Req'd
1	BH-1001	Hook Assembly-Upper with Latch (Includes Items 21, 22, 23 & 51) (for 1/4 & 1/2 ton)	1*
	BH1001A	Hook Assembly-Upper with Latch (Includes Items 21, 22, 23 & 51) (for 1 ton)	
	BH-1167	Spacer Washer Under Hook - Not Shown	1
3	BH-1003	Frame Assembly (For Hoists with Cat. No. prefix letters A, C, G, H & J. Includes 2 bushings, 1 needle bearing, 1 cup, 1 oil seal, 1 oil filter, 2 pipe plugs, and 2 dowel pins.)	1
	BH-1004	Frame Assembly (For Hoists with Cat. No. prefix letters D, K, L, P, M, S, T, W, & V. Includes 2 bushings, 2 needle bearings, 1 oil seal, 1 oil filler, 2 pipe plugs and 2 dowel pins.)	1
	BH-1 081	Frame Assembly (For 1/4 & 1/2 ton special sealed frame hoists with suffix -4, -5). Includes sealed frame, 2 bushings, 1 needle bearing, 2 oil seals, 1 oil filler, 2 pipe plugs, and 2 dowel pins.	1
	BH-1094	Frame Assembly (For 1 & 2 ton special sealed frame hoists with suffix -4, -5). Includes sealed frame, 2 bushings, 2 needle bearings, 2 oil seals, 1 oil filler, 2 pipe plugs, and 2 dowel pins.	1
4	BH-1005	Pin-Support, chain guide	2
5	BH-1006	Gasket "O" Ring	4
6	BH-1007	Gasket-Gearcase	1
7	BH-1008	Cover Assembly-Gearcase (For Hoists with Cat. No. prefix letters A, C, G, H & J. Includes 1 needle bearing, 1 cup and 2 grooved pins).	1

(Continued on following page)

Figure 9-1. FRAME AND EXTERNAL PARTS - Continued

Ref. No.	Part Number	Description	Qty. Req'd
	BH-1009	Cover Assembly -Gearcase (For Hoists with Cat. No. prefix letters D, K, L, P, M, S, T, W, & V. Includes 2 needle bearings and 2 grooved pins).	1
	BH-1082	Cover Assembly-Gearcase (For 1/4 & 1/2 ton special sealed frame Hoists with suffix -4, -5). Sealed and includes 1 needle bearing, 1 cup and 2 grooved pins.)	1
	BH-1095	Cover Assembly-Gearcase (For 1 & 2 ton special sealed frame Hoists with suffix -4, -5). Sealed and includes 2 needle bearings and 2 grooved pins.)	1
8	BH-1157	Cover Assembly-Gearcase (For Two Speed Hoists with 2-1/4 Horsepower Motor Only.)	1
	BH-1010	Cable Assembly-Flexible, 5' (Incl. Items 9 & 10)	1
		115 volt, 1 phase, 60 hertz hoists	1
		230 volt, 1 phase, 60 hertz hoists	1
		200/230/460/575 volt, 3 phase, 60 hertz hoists	1
9	BH-1096	Grommet-Flexible Cable-3 phase	1
		Grommet-Flexible Cable-1 phase	1
10	BH-1014	Clamp-Flexible Cable	1
11		Cover-Electrical Compartment	1
	BH-1168	Without internal counterweight	1
	BH-1169	With internal counterweight	1
		Capacity Label (Not Shown)	1
	YH-1190	1/4 Ton	
	YH-1191	1/2 Ton	
	YH-1192	1 Ton	
	YH-1193	2 Ton	
	YH-1194	3 Ton	
12	BH-1020	Screw-Fillister Head Machine	3
13	BH-1021	Hi-Collar Helical Spring Lock Washer (1/4)	3
14	BH-1022	Ring-Retaining	8
15	BH-1023	Regular Helical Spring Lock Washer (#10 Pltd.)	8
16	BH-1024	Hex Socket Head Cap Screw (#10-24 x 3/4)	2
17	BH-1025	Grooved Pin (Type D 1/8 x 1/2 Pltd.)	1
18	BH-1026	Grommet-(Motor Driven Trolley Models)-Not Shown	2
19	BH-1027	Dowel Pin (3/8 x 3/4)	2
20	BH-1028	Hex Socket Pipe Plug (1/8)	1
21	BH-1029	Washer-Thrust, upper hook	1
22	BH-1030	Grooved Pin (Type F 3/16 x 1-1/4 Pltd.)	1
23	**	Nut-Upper Hook	
24		Guide Assembly-Link Load Chain	1
	BH-1031	1/4 & 1/2 ton Hoists	
	BH-1032	1 thru 3 ton Hoists	
25	***	Chain Assembly-Link, load	1*
	BH-1033	1/4" Dia.-1/4 & 1/2 ton Hoists	
	BH-1034	5/16" Dia.-1 ton Hoists	
	BH-1080	1/4" Dia.-1/4 & 1/2 ton Hoists - Zinc Plated	
	BH-1086	5/16" Dia.-1 ton Hoists - Zinc Plated	
26	***	Chain Assembly-Roller, load	1*
	BH-1039	5/8" Pitch-For 1/4, and 1/2 ton Hoists	
	BH-1040	3/4" Pitch-For 1 ton Hoists	
	BH-1075	Repair Link-5/8" Pitch Roller Chain (not shown)	1
	BH-1076	Repair Link-3/4" Pitch Roller Chain (not shown)	1
27	BH-1171	Slotted Spring Pin (3/32 x 5/8 Pltd.)	1
28		Adapter Kit-Roller Load Chain (Incl. Items 27, 28, 29, 40 and 41)	1
	BH-1172	5/8" Pitch-For 1/4, and 1/2 ton hoists	
	BH-1173	3/4" Pitch-For 1 ton hoists	
29	BH-1043	Pin-Adapter, roller load chain (5/8" Pitch)	1
	BH-1044	Pin-Adapter, roller load chain (3/4" Pitch)	1*
30		Block Assembly-Lower, link and roller chain (Incl. items 32 thru 39)	1*
	BH-1035	For 1/4 ton Hoists	
	BH-1035A	For 1/2 ton Hoists	
	BH-1036	For 1 ton Hoists	
		Note: Lower block assemblies do not include attaching pins or roller chain adaptor. Order separately.	

(Continued on following page)

Figure 9-1. FRAME AND EXTERNAL PARTS - Continued

Ref. No.	Part Number	Description	Qty. Req'd
32	BH-1174	Body-Lower Block, link and roller chain 1/4 ton Hoists	1*
	BH-1174A	1/2 ton Hoists	
	BH-1175	1 ton Hoists	
33		Hook, Nut and Latch Assembly-Lower Block	1
	BH-1176	1/4 and 1/2 ton Hoists	
	BH-1177	1 ton Hoists	
34		Latch Kit-Hook, lower	1
	BH-1182	1/4, and 1/2 ton Hoists	
	BH-1183	1 ton Hoists	
35	BH-1178	Washer-Thrust, needle bearing	2
36	BH-1179	Bearing Assembly-Needle, thrust	1
37	BH-1180	Shield-Bearing	1
38	BH-1181	Grooved Pin (Type F 5/32 x 1-1/8 Pltd.)	1
39	**	Nut-Hook	1
40		Pin-Connecting, lower block	1
	BH-1037	1/4 and 1/2 ton Hoists	
	BH-1038	1 ton Hoists	
41	BH-1045	Slotted Spring Pin (3/32 x 3/4 Pltd.)	1
42		Stripper-Roller Chain	1
	BH-1046	1/4 and 1/2 ton Hoists	
	BH-1047	1 & 2 ton Hoists	
43		Guide Assembly-Roller Chain	1
	BH-1048	1/4 and 1/2 ton Hoists	
	BH-1049	1 & 2 ton Hoists	
44		Link Assembly-Roller Chain (For connecting tail end of chain only - Must not be used to join chain.)	1
	BH-1050	1/4 & 1/2 ton Hoists	
	BH-1 051	1 & 2 ton Hoists	
45	BH-1052	Fillister Head, Self Locking Machine Screw (5/16-18 x 3/4 Pltd.)	1
46		Anchor-Link, roller load chain	1
	BH-1053	1/4 & 1/2 ton Hoists	
	BH-1054	1 & 2 ton Hoists	
47	††	Actuator-Limit Lever	2
	BH-1098	For 1/4" Dia. Link Chain and 5/8" Pitch Roller Chain	
	BH-1099	For 5/16" Dia. Link Chain and 3/4" Pitch Roller Chain	
48	BH-1184	Grooved Pin (For Actuator BH-1098) (Type F 7/32 x 2 Pltd.)	2
	BH-1185	Grooved Pin (For Actuator BH-1099) (Type F 1/4 x 2 Pltd.)	2
49	BH-1057	Bushing-Control Shaft	2
50	BH-1058	Filler Assembly-Oil	1
51	BH-1183	Latch Kit-Hook (upper) 1/4 thru 1 ton	1
52	BH-1089*	Slotted Spring Pin (1/4 x 11/16 Pltd.)	2
53	BH-1088*	Stud-Suspension, nut and pin (Includes item 55.)	1
54	BH-1087*	Bracket-Suspension	1*
55	BH-1092	Washer (.0747 Thk.)	1
	BH-1186	Washer (.0478 Thk.)	As Req'd.
		The following items are for two speed hoists with 2-1/4 horsepower motor only:	
58	BH-1158	Insert-Coil	3
59		Support Stud	
	BH-1159	Top	2
	BH-1160	Bottom	1

(Continued on following page)

Figure 9-1. FRAME AND EXTERNAL PARTS - Continued

Ref. No.	Part Number	Description	Qty. Req'd
60	BH-1161	Counterweight	1
61	BH-1162	Plain Washer (Type W 1/4 Pltd.)	3
62	BH-1163	Heavy Hex Self-Locking Nut (1/4 - 20)	3
63		Capacity Label	1
	YH-1164	1 Ton	
	YH-1165	2 Ton	
	YH-1166	3 Ton	

* Refer to Figure 9-2 for 2 Ton Model Upper Suspension, Load Chain and Lower Block Parts.

Refer to Figure 9-3 for 3 Ton Model Upper Suspension, Load Chain and Lower Block Parts.

Later model hoists also have a set screw (BH-1199) to lock rotation.

** Hook and suspension bolt nuts are not serviced separately. They are available only with hook or bolt as assemblies.

** Load Chain Assemblies listed are for hoists with standard 10 ft. lifts. Bulk chain is available in 1 ft. increments and 50 ft. lengths as follows:



Type Chain	50' Lengths	Bulk
Roller (5/8" Pitch)	BH-1064	BH-1065
Roller (3/4" Pitch)	BH-1067	BH-1068
Link (1/4" Dia.)	Not Available	BH-1066
Link (5/16" Dia.)	Not Available	BH-1069
Link (1/4" Dia. Zinc Plate)	Not Available	BH-1083
Link (5/16" Dia. Zinc Plate)	Not Available	BH-1093

†† A urethane Bumper (BH-1063) is used over the top of the steel limit level actuator at lower block on all high speed 64 fpm hoists, 32 fpm 1 Ton (2½ hp) hoists, and single phase 32 fpm hoists.

To enable us to expedite your parts order, always give Model and Catalog Number and Electric Current of Hoist. (See nameplate.)

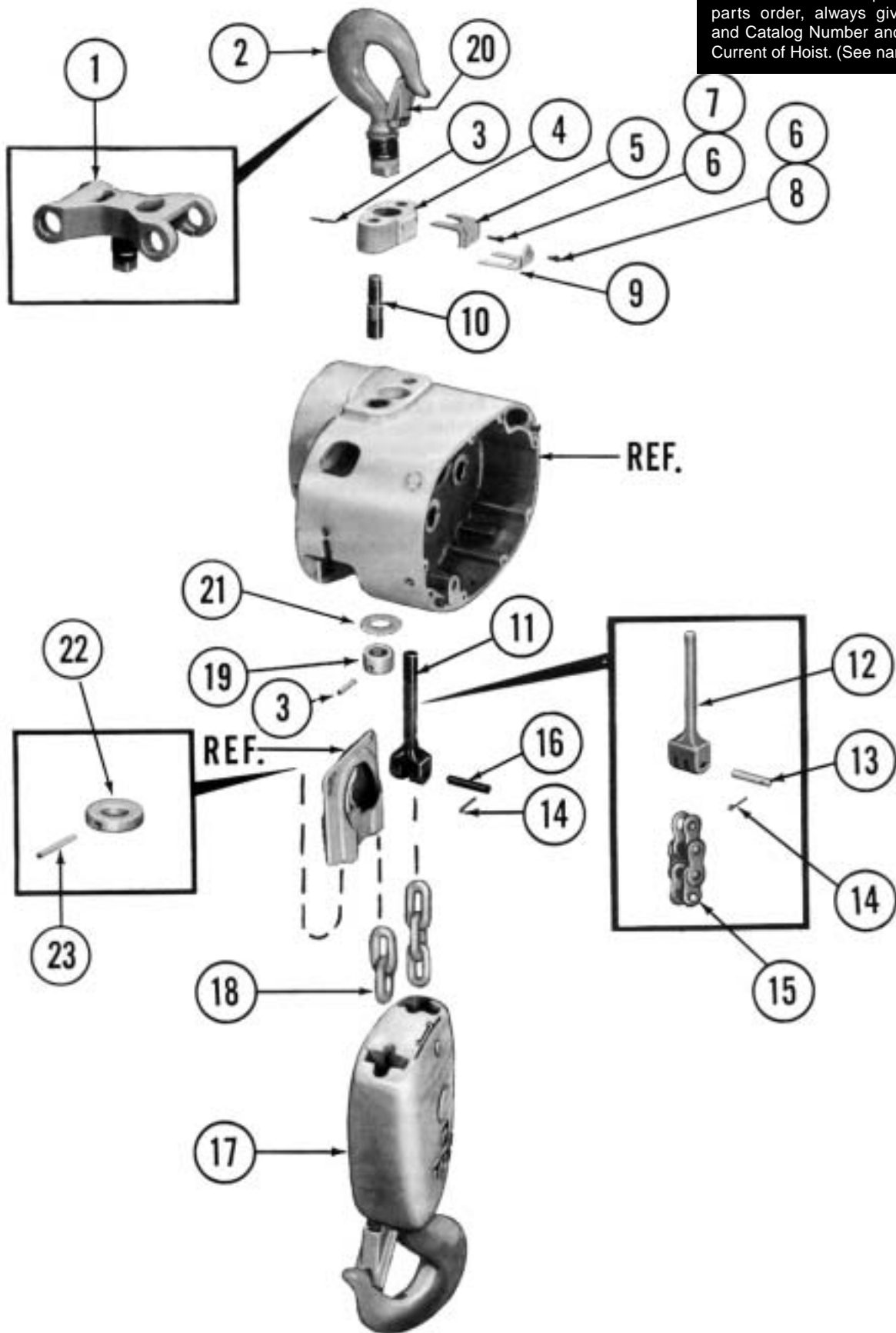

Figure 9-2. UPPER SUSPENSION, LOAD CHAIN AND LOWER BLOCK PARTS
(2 Ton Hoists)

Figure 9-2. UPPER SUSPENSION, LOAD CHAIN AND LOWER BLOCK PARTS - Continued

Ref. No.	Part Number	Description	Qty. Req'd
1	905422	Bracket Assembly Kit- Lug Suspension (Link Chain Model Only. Includes Items 6, 8 and 9).	1
2	BH-1102	Hook Assembly-Upper (Includes Items 5, 6, 7 and 20).	1
3	BH-1030	Grooved Pin (Type F 3/16 x 1-1/4 Pltd.)	3
4		Block Assembly-Upper	1
	BH-1104	Link Chain Models, Includes Items 3, 10, 11, 14, 16, 19 and 21	
	BH-1105	Roller Chain Models, Includes Items 3, 10, 12, 13, 14, 19 and 21	
5	BH-1106	Lock Assembly-Suspension Bushing	1
6	BH-1107	Regular Helical Spring Lock Washer (#10 Pltd.)	3
7	BH-1108	Hex, Socket Head Cap Screw (#10-24 x 1/2)	2
8	BH-1109	Hex, Socket Head Cap Screw (#10-24 x 3/8)	1
9	BH-1061	Plate - Lock (Link Chain Lug Suspension Models Only)	1
10		Stud - Upper Block	1
11		Anchor - Link Load Chain	1
12		Anchor - Roller Load Chain	1
13	BH-1110	Pin - Roller Chain Anchor	1
14	BH-1111	Cotter Pin (3/32 x 3/4)	1
15**	BH-1112	Chain Assembly-Roller Load (3/4" Pitch)	1
	BH-1076	Repair Link-3/4" Pitch Roller Chain (Not Shown)	As Req'd.
16	BH-1113	Pin-Link Chain Anchor	1
17	(See Fig. 9-4)	Block Assembly-Lower (Link Chain Models)	1
	(See Fig. 9-5)	Block Assembly-Lower (Roller Chain Models)	1
18**	BH-1114	Chain Assembly-Link Load	1
	BH-1115	Chain Assembly-Link Load (Zinc Plated)	1
19	*	Nut-Upper Block Stud	1
20	BH-2213	Latch Kit-Hook	1
21	BH-1029	Washer-Thrust	1
22	BH-1099	Actuator-Limit Lever	1
23	BH-1185	Grooved Pin (Type F 1/4 x 2 Pltd.)	1

* Not available as individual parts. Order upper block assembly, Item 4.

** Load Chain Assemblies listed are for hoists with standard 10 ft. lists. Bulk chain is available in 1 ft. increments and 50 ft. lengths as follows:

Type Chain	50' Lengths	Bulk
Roller (3/4" Pitch)	BH-1067	BH-1068
Link (5/16" Dia.)	Not Available	BH-1069
Link (5/16" Dia. Zinc Plate)	Not Available	BH-1093

To enable us to expedite your parts order, always give Model and Catalog Number and Electric Current of Hoist. (See nameplate.)

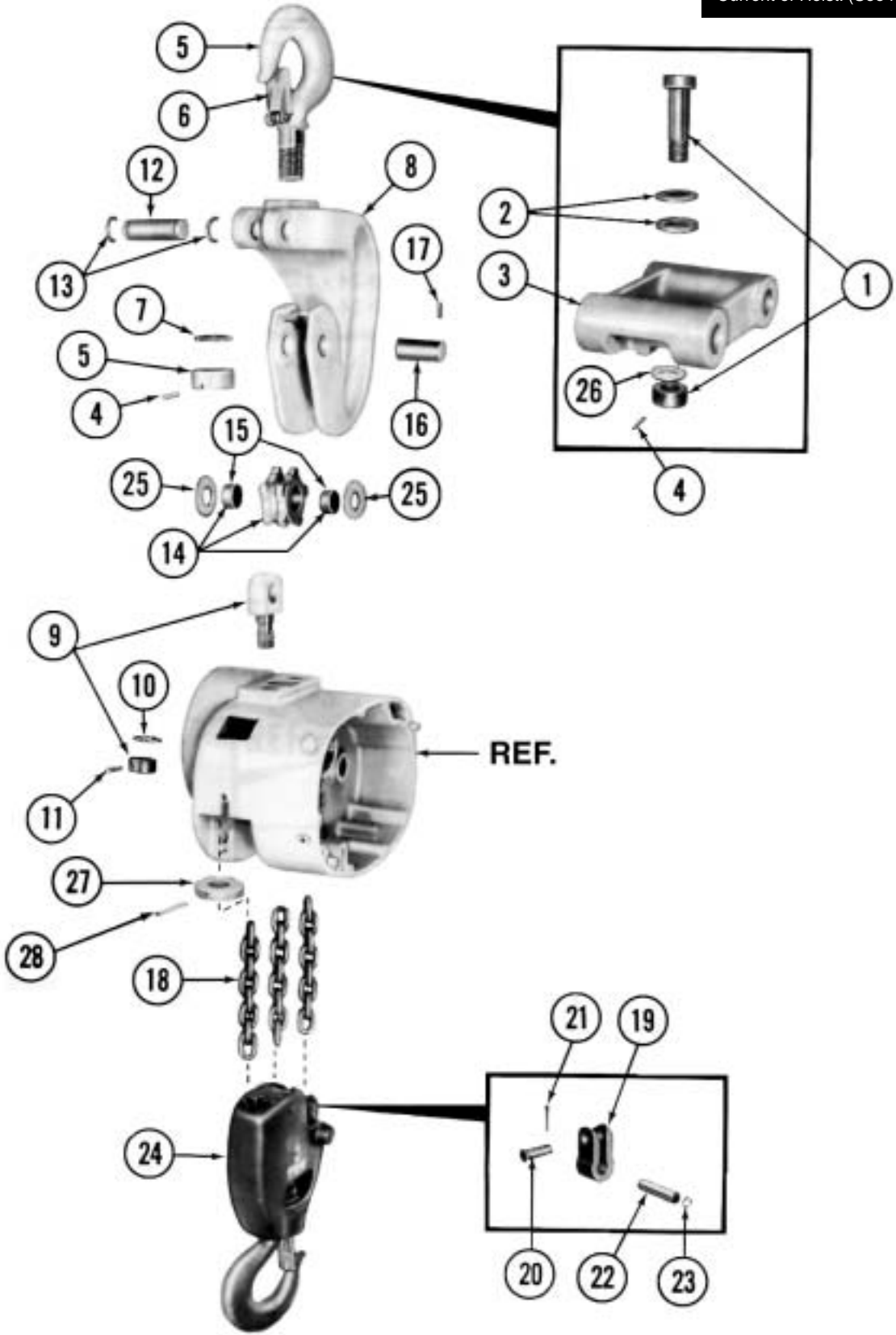

Figure 9-3. UPPER SUSPENSION, LOAD CHAIN AND LOWER BLOCK PARTS (3 Ton Hoists)

Figure 9-3. UPPER SUSPENSION, LOAD CHAIN AND LOWER BLOCK PARTS - Continued

Ref. No.	Part Number	Description	Qty. Req'd
1	BH-1131	Suspension Pin and Nut Assembly	1
2	BH-1132	Spherical Washer	1 Pr.
3	905424	Suspension Lug Kit (Includes Items 1, 2, 4 and 26)	1
4	BH-1134	Pin - Grooved (Type A 3/16 x 2 Pltd.)	1
5	BH-1135	Hook/Latch and Nut (Includes Item 6)	1
6	BH-2214	Latch Kit, Hook	1
7	BH-2217	Washer, Thrust	1
8	BH-1138	Hanger	1
9	BH-1139	Connecting Rod Assembly	1
10	BH-1029	Washer, Thrust	1
11	BH-1030	Grooved Pin (Type F 3/16 x 1-1 /4 Pltd.)	1
12	BH-1142	Pin, Connection	1
13	BH-1143	Ring, Retaining	2
14	BH-1144	Sprocket & Bushing Assembly (Includes Item 15)	1
15	BH-1145	Bushing	2
16	BH-1146	Pin, Sprocket	1
17	BH-1147	Grooved Pin (Type A 3/16 x 3/8 Pltd.)	1
18	BH-1148	Chain Assembly, Coil Load	1
19	BH-1149	Link, Connecting	1
20	BH-1150	Pin, Anchor	1
21	BH-1151	Cotter Pin (3/32 x 3/4)	1
22	BH-1152	Dowel Pin (1/2 x 2-1/4)	1
23	BH-1153	Ring, Retaining	1
24	See Fig. 9-4	Block Assembly, Lower, Coil Chain	1
25	BH-2210	Washer, Thrust	2
26	BH-1154	Washer	1
27	BH-1099	Actuator - Limit Lever	1
28	BH-1185	Grooved Pin (Type F 1/4 x 2 Pltd.)	1

NOTICE

Always insist on factory approved **Budgit** Hoist replacement parts when servicing this equipment. Parts are available from your local Authorized Repair Station.

NOTES

To enable us to expedite your parts order, always give Model and Catalog Number and Electric Current of Hoist. (See nameplate.)

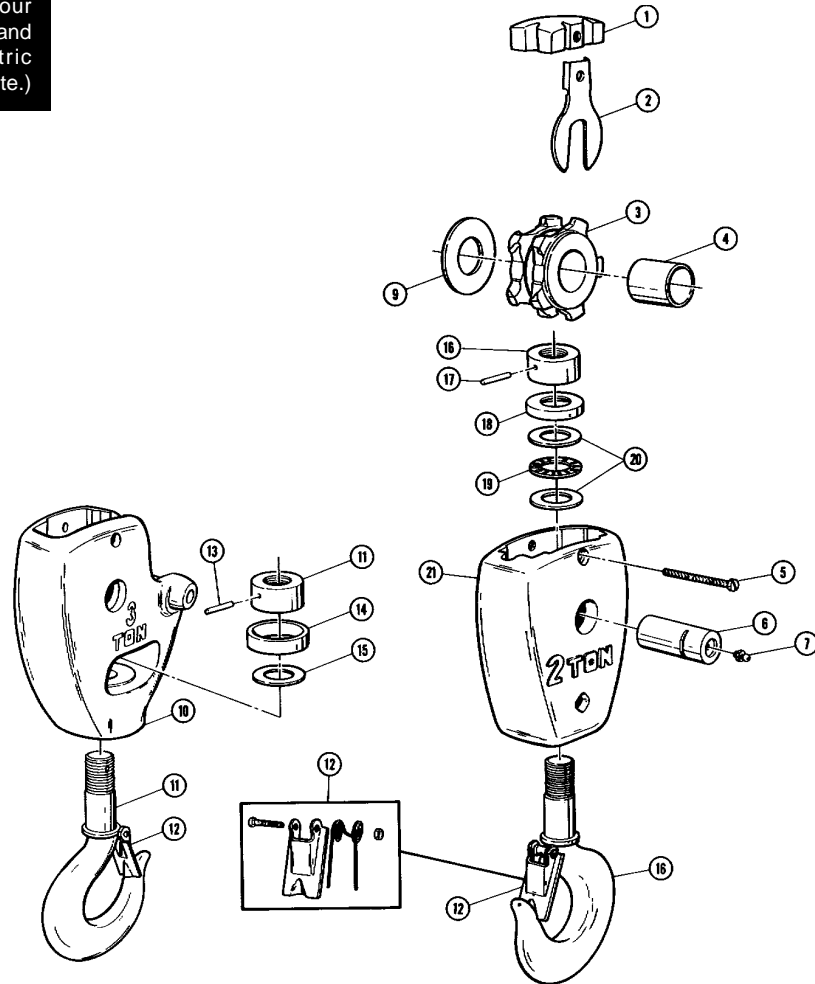

12444A

Figure 9-4. 2 and 3 TON LOWER BLOCK ASSEMBLIES (Link Chain Hoists)

Ref. No.	Part Number	Description	Quantity Required	
			2 Ton	3 Ton
	BH-2219	Block Assembly-Lower Complete	1	—
1	BH-2218	Block Assembly-Lower Complete	—	1
	BH-2202	Guide-Center	1	1
2	BH-2203	Lock-Sprocket Pin	1	1
3	BH-2204	Sprocket-Coil Chain	1	1
4	BH-2205	Bushing-Sprocket	1	1
5	BH-2206	Screw-Fillister Head, Self locking	1	1
6	BH-2207	Pin-Sprocket	1	1
7	BH-2208	Fitting-Hydraulic Drive	1	1
9	BH-2210	Washer, Thrust	1	1
10	BH-2211	Body Assembly-Lower Block	—	1
11	BH-2212	Hook/Latch and Nut (Includes Items 12, 13 and 15)	—	1
12	BH-2213	Latch Kit, Hook	1	—
	BH-2214	Latch Kit, Hook	—	1
13	BH-2215	Pin, Grooved	—	1
14	BH-2216	Shroud	—	1
15	BH-2217	Washer, Thrust	—	1
16	BH-2220	Hook/Latch and Nut (Includes Items 12 and 17)	1	—
17	BH-2221	Pin, Grooved	1	—
18	BH-2222	Shield, Bearing	1	—
19	BH-2223	Bearing Assembly-Needle, Thrust	1	—
20	BH-2224	Washer, Thrust	2	—
21	BH-2225	Body-Lower Block	1	—

To enable us to expedite your parts order, always give Model and Catalog Number and Electric Current of Hoist. (See nameplate.)

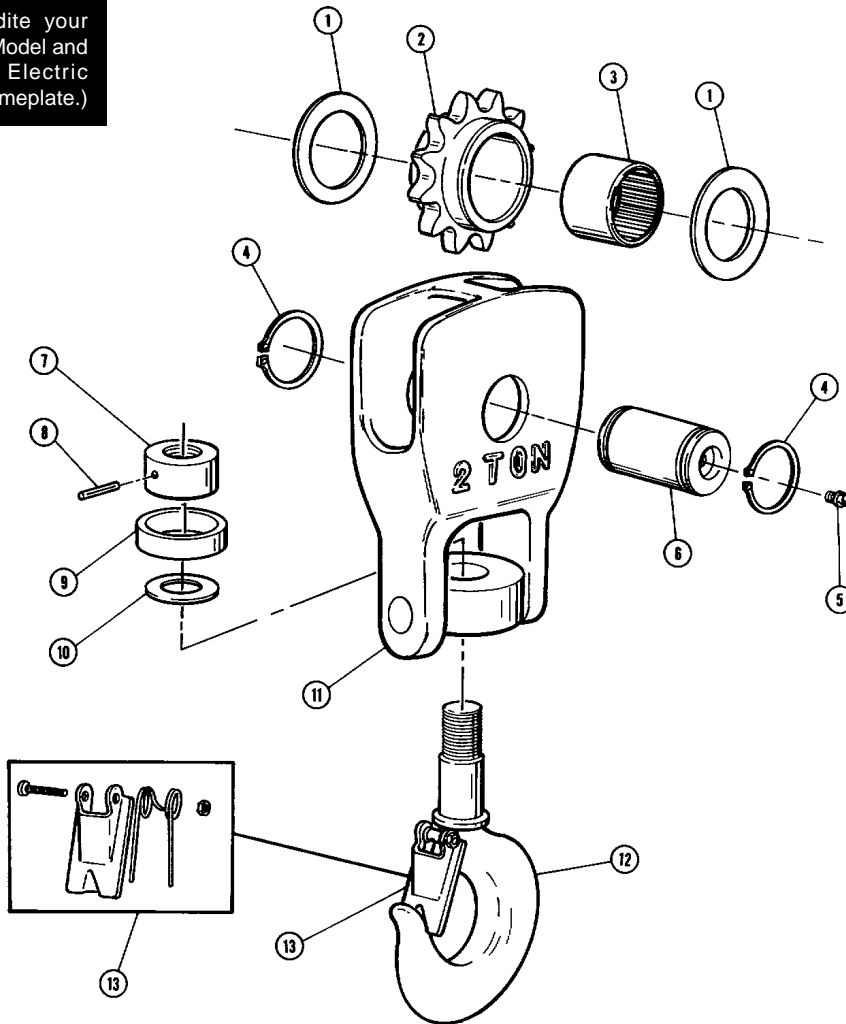

10263B

Figure 9-5. 2 TON LOWER BLOCK ASSEMBLY (Roller Chain Hoists)

Ref. No.	Part Number	Description	Qty. Req'd
1	BH-2301	Block Assembly-Lower, Complete	1
2	BH-2302	Washer-Spring Thrust	2
3	BH-2303	Sprocket-Chain	1
4	BH-2304	Bearing Assembly-Needle	1
5	BH-2305	Ring-Retaining, External	2
6	BH-2208	Fitting-Hydraulic Drive	1
7	BH-2307	Pin-Sprocket	1
8	BH-2308	Hook and Nut Assembly-Lower Block (Includes Item 12 below)	1
9	BH-2311	Pin-Grooved	1
10	BH-2312	Shroud	1
11	BH-2313	Washer-Thrust	1
12	BH-2315	Body Assembly	1
13	BH-2308	Hook and Nut Assembly	1
	BH-2213	Latch Kit-Hook	1

NOTICE

Always insist on factory approved **Budgit** Hoist replacement parts when servicing this equipment. Parts are available from your local Authorized Repair Station.

To enable us to expedite your parts order, always give Model and Catalog Number and Electric Current of Hoist. (See nameplate.)

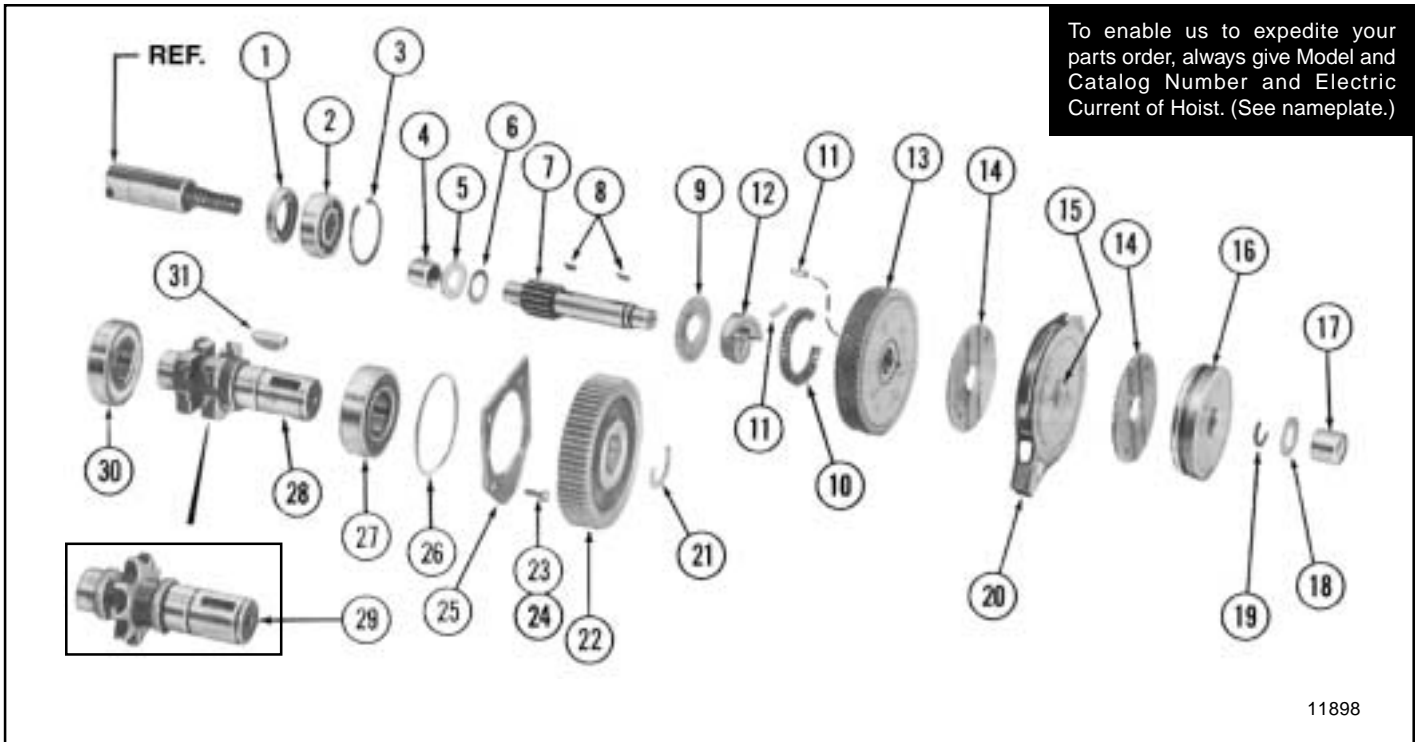

Figure 9-6. GEARING AND LOAD BRAKE PARTS (1/4 and 1/2 Ton Hoists)

Ref. No.	Part Number	Description	Qty. Req'd
1	BH-1201	Seal-Oil, motor shaft	1
2	BH-1202	Bearing Assembly-Ball, motor shaft	1
3	BH-1203	Ring-Retaining, Internal	1
4	BH-1237	Bearing Assembly-Needle, 11/16" I.D. (36 rollers, grease retained)	1
5	BH-1205	Bearing-Thrust, bronze	1
6	BH-1206	Washer-Thrust, 11/16" I. D. (Used with 14 tooth Pinion Load Brake Shaft-13H-1207 below)	1
7		Shaft & Integral Pinion-load brake,	
	BH-1207	14 teeth	1
	BH-1208	23 teeth	
	BH-1209	36 teeth	
8	BH-1210	Key-Woodruff	2
9	BH-1239	Retainer-Spring, load brake	1
10	BH-1212	Spring-load brake (Plain-no color code)	1
	BH-1213	Spring-load brake (Yellow color code)	1
11	BH-1214	Pin-Grooved	2
12	BH-1216	Cam-load brake	1
13		Gear & Clutch Assembly-load brake	
	BH-1240	For use with 1/4 H.P. Motor	
	BH-1241	For use with 1 /2 H.P. Motor	
	BH-1242	For use with 1 H.P. Motor	
14	BH-1218	Disc-Friction, load brake	2
15	BH-1238	Bushing—Ratchet	2
16	BH-1219	Flange—load brake	1
17	BH-1220	Bearing Assembly-Needle, 5/8" I.D.	1
18	BH-1221	Washer-Thrust, 5/8" I.D.	1
19	BH-1222	Ring-Snap, brake flange	1
20	BH-1223	Pawl & Ratchet Assembly-load brake (includes item 15)	1
21	BH-1224	Ring-Snap, sprocket gear	1
22		Gear-Sprocket	
	BH-1225	74 teeth	1
	BH-1226	65 teeth	
	BH-1227	52 teeth	

(Continued on following page)

Figure 9-6. GEARING AND LOAD BRAKE PARTS - Continued

Ref. No.	Part Number	Description	Qty. Req'd
23	BH-1228	Screw - Fillister Head Machine	4
24	BH-1229	Lockwasher- Spring Type	4
25	BH-1230	Plate - Retainer, Sprocket Bearing	1
26**	BH-1231	Gasket - Ring, Sprocket Bearing	1
27	BH-1232	Bearing Assembly- Ball, Sprocket	1
	BH-1318	Ball Bearing On Later Model Hoists	1
28**	BH-1233	Sprocket-Coil Chain (1/4" Dia. Wire)	1
29**	BH-1234	Sprocket - Roller Chain (5/8" Pitch)	1
30	BH-1235	Bearing Assembly - Ball, Sprocket	1
31	BH-1236	Key - Woodruff	1
32**	BH-1315	O-Ring	1
33**	BH-1316	Seal Disk	1
34**	BH-1317	Seal - Oil	1

* This gear and clutch assembly should not be field disassembled. Replace assembly only as clutch pressure is preset at factory based on hoist capacity and motor H.P.
 ** On later model hoists; Ref. No. 26 is replaced by Ref. Nos. 32, 33 and 34 and BH-1233 and BH-1234 are replaced by BH-1311 and BH-1313.

NOTES

To enable us to expedite your parts order, always give Model and Catalog Number and Electric Current of Hoist. (See nameplate.)

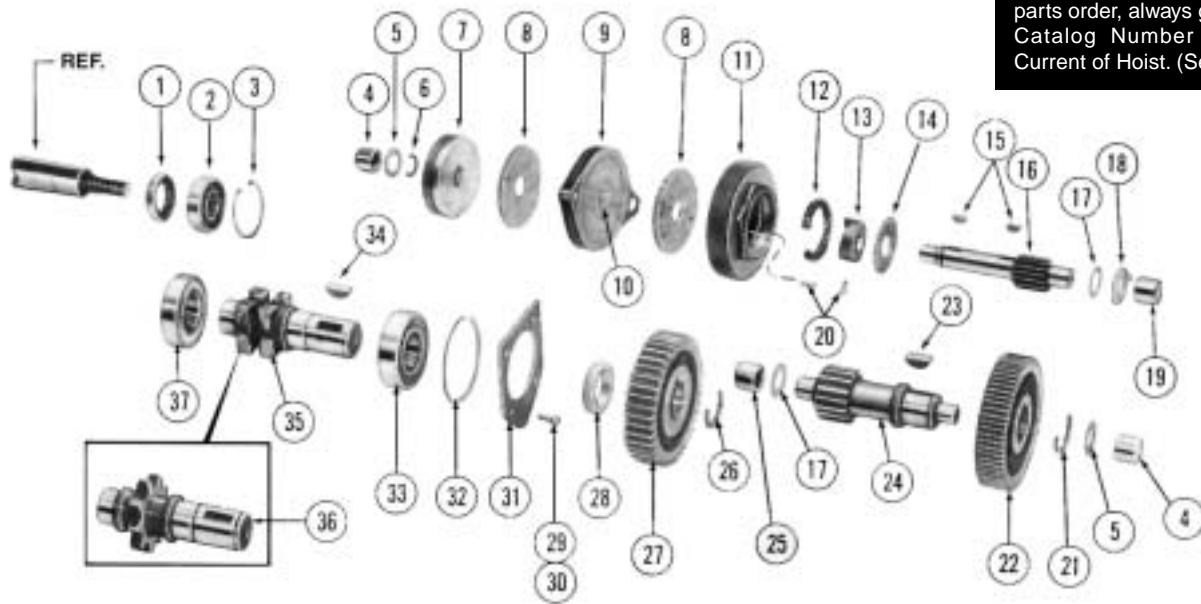

11899

Figure 9-7. GEARING AND LOAD BRAKE PARTS (1 thru 3 Ton Hoists)

Ref. No.	Part Number	Description	Qty. Req'd
1	BH-1201	Seal-Oil, motor shaft	1
2	BH-1202	Bearing Assembly-Ball, motor shaft	1
3	BH-1203	Ring-Retaining, Internal	1
4	BH-1220	Bearing Assembly-Needle, 5/8" I.D.	2
5	BH-1221	Washer-Thrust, 5/8" I.D.	2
6	BH-1222	Ring-Snap, brake flange	1
7	BH-1219	Flange-Load Brake	1
8	BH-1218	Disc-Friction, load brake	2
9	BH-1223	Pawl and Ratchet Assembly-Load Brake (includes item 15)	1
10	BH-1238	Bushing-Ratchet	1
11	BH-1241	Gear and Clutch Assembly-Load Brake For use with 1 /2 H.P. Motor	1
	BH-1242	For use with 1 and 2-1/2 H.P. Motors	
12	BH-1212	Spring-Load Brake (Plain-no color code)	1
13	BH-1216	Cam-Load Brake	1
14	BH-1239	Retainer-Spring, Load Brake	1
15	BH-1210	Key-Woodruff	2
16	BH-1207	Shaft and Integral Pinion-Load Brake 14 teeth	1
	BH-1208	23 teeth	
17***	BH-1206	Washer-Thrust, 11/16" I.D.	2
18	BH-1205	Bearing-Thrust, bronze	1
19	BH-1204	Bearing Assembly-Needle, 11 /16" I.D.	1
20	BH-1214	Pin-Grooved	2
21	BH-1224	Ring-Snap, intermediate gear	1
22	BH-1225	Gear-Intermediate 74 teeth	1
	BH-1226	65 teeth	
23	BH-1236	Key-Woodruff	1
24	BH-1304	Shaft and Integral Pinion-Intermediate	1
25	BH-1237	Bearing Assembly-Needle, 11/16" I.D.	1
26	BH-1305	Ring-Snap, sprocket gear	1
27	BH-1306	Gear-Sprocket	1
28**	BH-1307	Spacer-Sprocket Gear	1
29	BH-1228	Screw-Fillister Head Machine	4

(Continued on following page)

Figure 9-7. GEARING AND LOAD BRAKE PARTS - Continued

Ref. No.	Part Number	Description	Qty. Req'd
30	BH-1229	Lockwasher - Spring Type	4
31	BH-1230	Plate - Retainer, Sprocket Bearing	1
32**	BH-1231	Gasket - Ring, Sprocket Bearing	1
33	BH-1232	Bearing Assembly - Ball, Sprocket	1
	BH-1318	Ball Bearing On Later Model Hoists	1
34	BH-1308	Key -Woodruff, Sprocket	1
35**	BH-1309	Sprocket - Coil Chain	
	BH-1311	Later Model Hoists: 1/4" Dia. Wire	1
	BH-1312	5/16" Dia. Wire	1
36**	BH-1310	Sprocket - Roller Chain	1
	BH-1313	Later Model Hoists: 5/8" Pitch	1
	BH-1314	3/4" Pitch	1
37	BH-1235	Bearing Assembly - Ball, Sprocket	1
38**	BH-1315	O-Ring	1
39**	BH-1316	Seal Disk	1
40**	BH-1317	Seal - Oil	1

- * This gear and clutch assembly should not be field disassembled. Replace assembly only as clutch pressure is preset at factory based on hoist capacity and motor H.P.
- ** On later model hoists; Ref. No. 28 is not used, Ref. No. 32 is replaced by Ref. Nos. 38, 39 and 40 and BH-1309 and BH-1310 are replaced by BH-1311 thru BH-1314 as shown above.
- *** Ref. No. 17 occurs next to Ref. No. 16 for 14 tooth pinion load brake shaft only.
Later model hoists are hoists starting with model number 116887

NOTES

To enable us to expedite your parts order, always give Model and Catalog Number and Electric Current of Hoist. (See nameplate.)

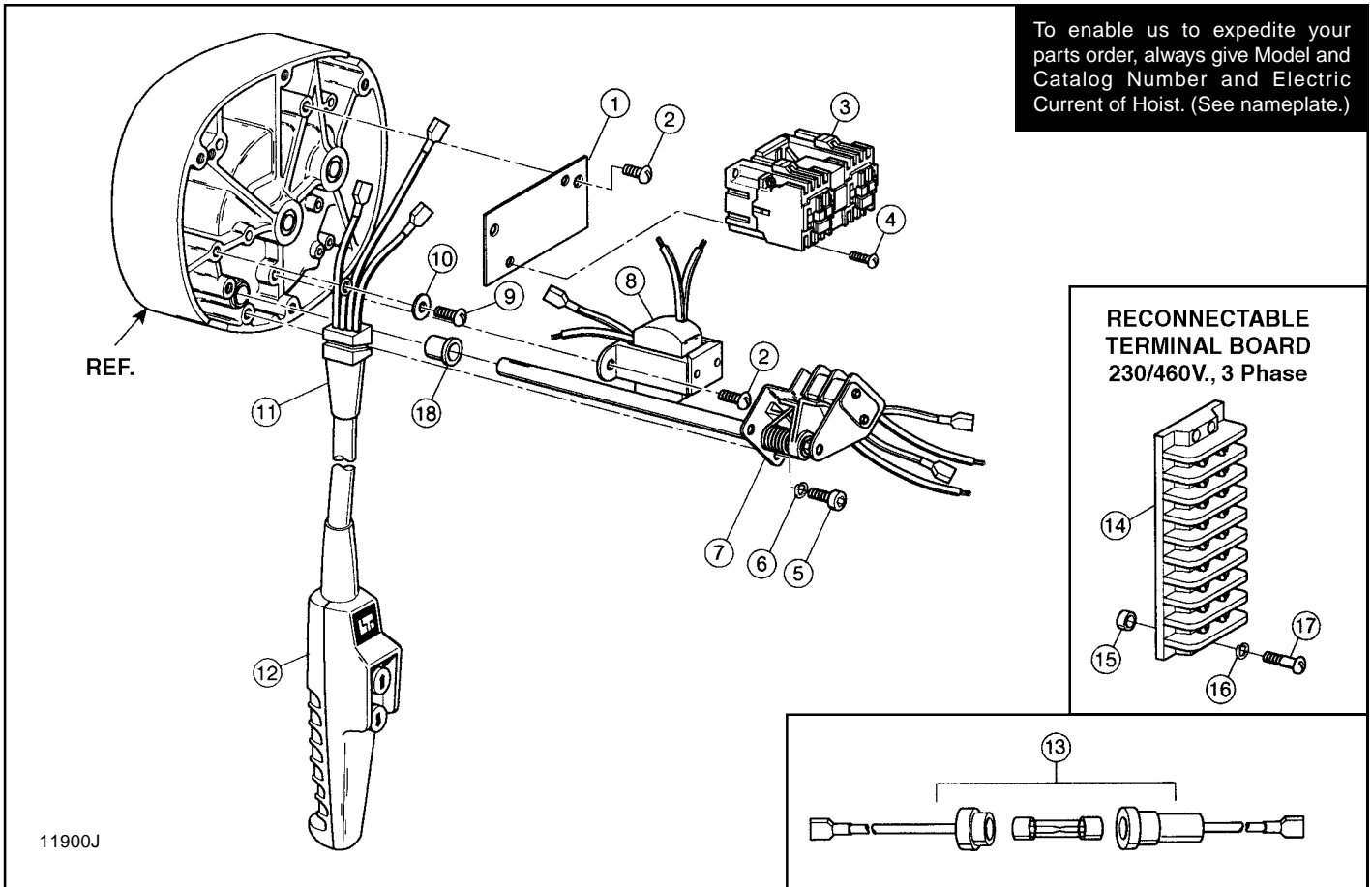

Figure 9-8A. ELECTRICAL CONTROL UNITS (Three phase Single Speed Hoists - Later Version)

Ref. No.	Part Number	Description	Qty. Req'd
		Contactor and Mounting Plate Assembly (Includes Ref. Nos. 1, 3 and 4)	1
	BH-3800	Three Phase 24V Control	
	BH-3801	Three Phase 115V Control	
1	BH-3802	Mounting Plate - Contactor	1
2	BH-2155	Sems Round Head Machine Screw with External Lock Washer (#10-24 x 3/8)	5
3		Contactor Assembly	1
	BH-3803	Three Phase 24V Control	
	BH-3804	Three Phase 115V Control	
4	BH-2189	Pan Head Self Tapping Screw (#8-32 x 1/2)	2
5	BH-2161	Hex Socket Head Cap Screw (#10-24 x 3/8 Pltd.)	2
6	BH-2162	Regular Helical Spring Lock Washer (#10 Pltd.)	2
7	See Fig. 9-11	Limit Switch and Shaft Assembly	1
8		Transformer	1
	BH-2166	Three Phase 208V/24V	
	BH-3805	Three Phase 230V/460V/24V	
	BH-2168	Three Phase 575V/24V	
	BH-2169	Three Phase 208V/115V	
	BH-3806	Three Phase 230V/460V/115V	
	BH-2172	Three Phase 575V/115V	

(Continued on following page)

To enable us to expedite your parts order, always give Model and Catalog Number and Electric Current of Hoist. (See nameplate.)

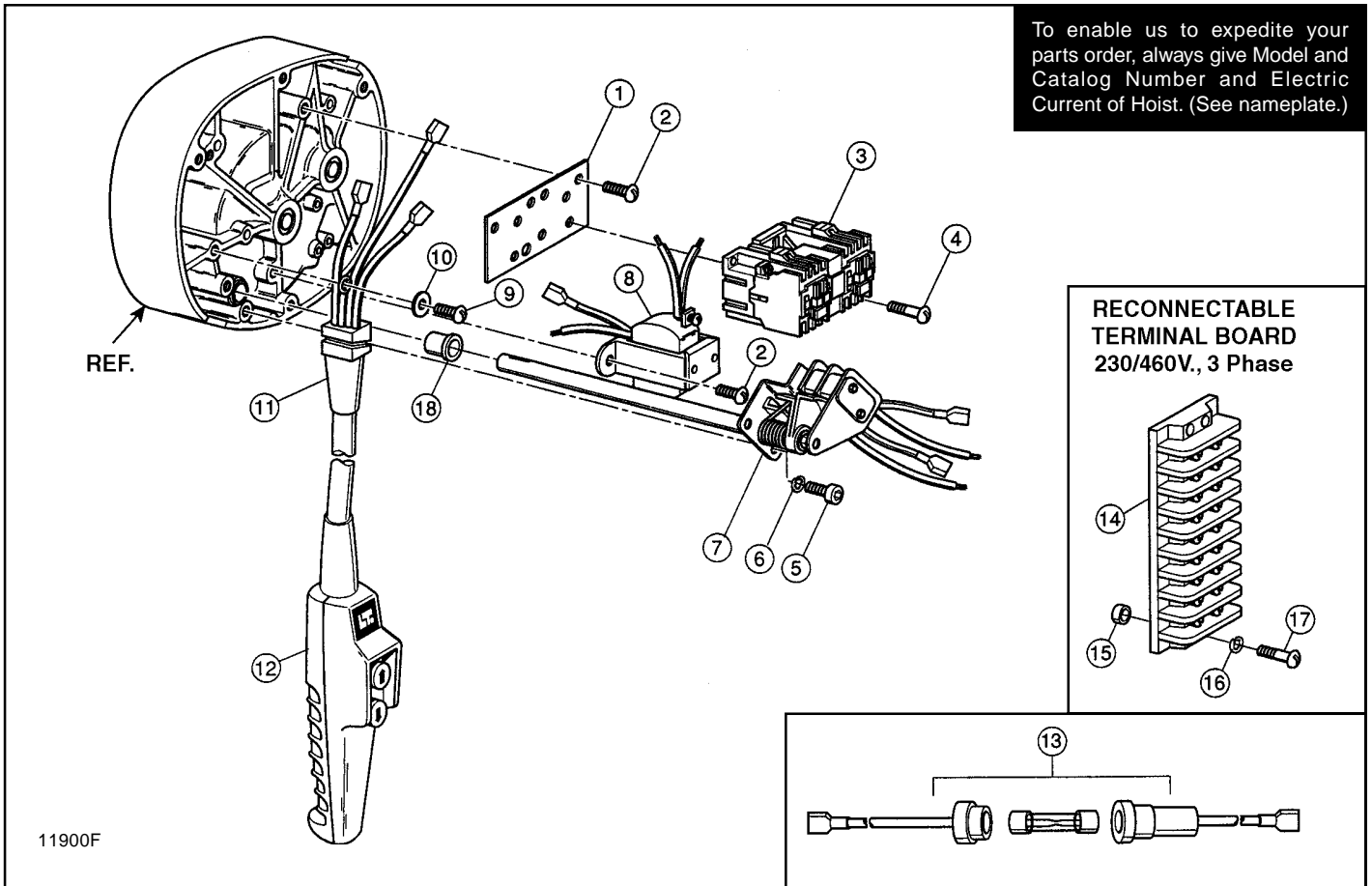

Figure 9-8. ELECTRICAL CONTROL UNITS (Three phase Single Speed Hoists - Earlier Version)

Ref. No.	Part Number	Description	Qty. Req'd
		Contactor and Mounting Plate Assembly (Includes Ref. Nos. 1, 3 and 4)	1
	BH-2150	Three Phase 24V Control	
	BH-2151	Three Phase 115V Control	
1	BH-2154	Mounting Plate-Contactor	1
2	BH-2155	Sems Round Head Machine Screw with External Lock Washer (#10-24 x 3/8)	4
3		Contactor Assembly	1
	BH-2156	Three Phase 24V Control	
	BH-2157	Three Phase 115V Control	
4	BH-2160	Round Head Machine Screw (#8-32 x 1/2)	2
5	BH-2161	Hex Socket Head Cap Screw (#10-24 x 3/8 Pltd.)	2
6	BH-2162	Regular Helical Spring Lock Washer (#10 Pltd.)	2
7	See Fig. 9-11	Limit Switch and Shaft Assembly	1
8		Transformer	1
	BH-2166	Three Phase 200V/24V	
	BH-2164	Three Phase 230V/24V	
	BH-2167	Three Phase 460V/24V	
	BH-2168	Three Phase 575V/24V	
	BH-2169	Three Phase 200V/115V	
	BH-2170	Three Phase 230V/115V	
	BH-2171	Three Phase 460V/115V	
	BH-2172	Three Phase 575V/115V	

(Continued on following page)

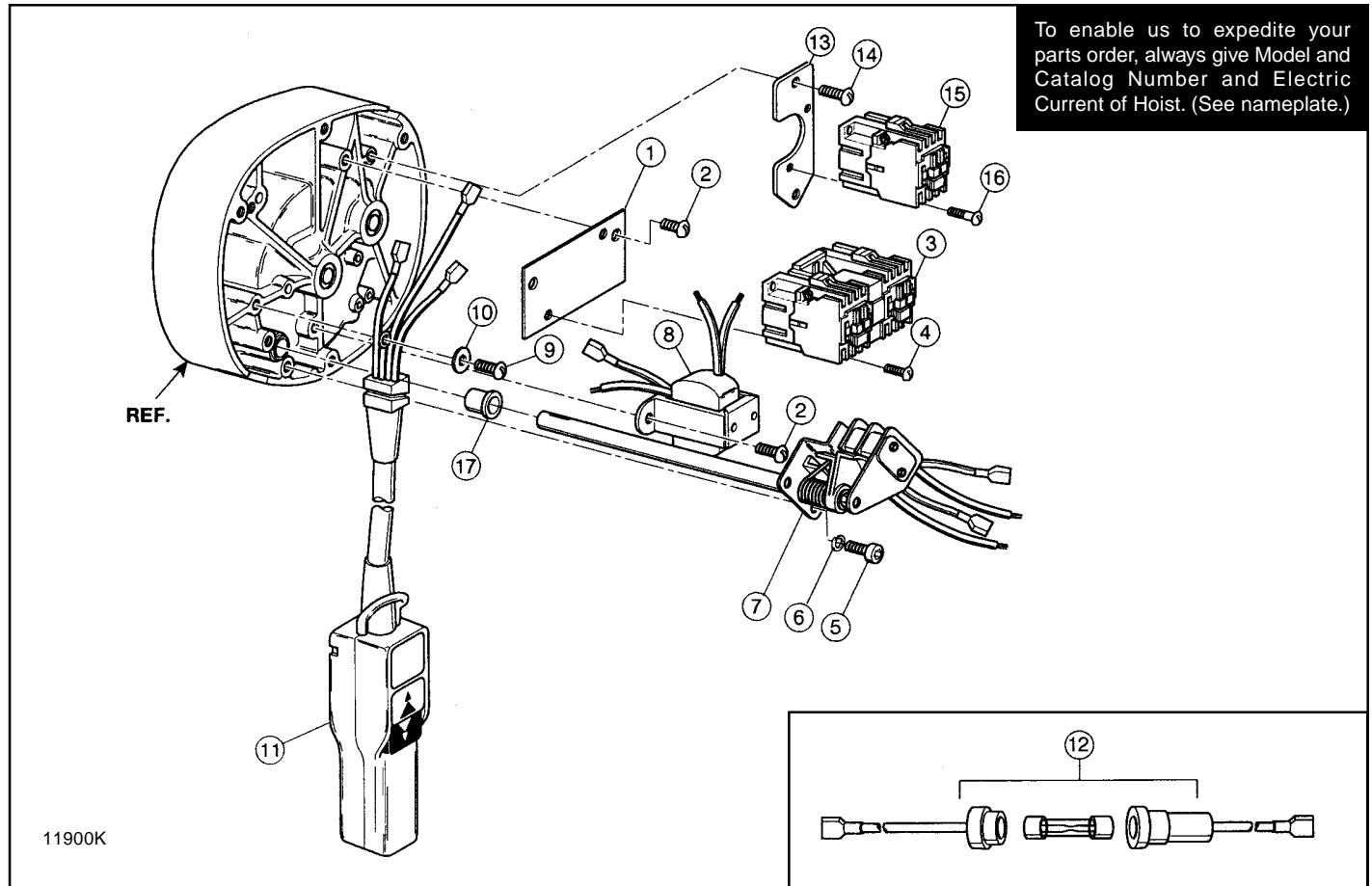

Figure 9-9A. ELECTRICAL CONTROL UNITS (Two Speed Hoists Only - Later Version)

Ref. No.	Part Number	Description	Qty. Req'd
1	BH-3800	Contractor and Mounting Plate Assembly (Includes Ref. Nos. 1, 3 and 4)	1
	BH-3801	Three Phase 24V Control	
2	BH-3802	Three Phase 115V Control	1
	BH-2155	Mounting Plate - Contactor	
3	BH-2155	Sems Round Head Machine Screw with External Lock	5
	BH-2155	Washer (#10-24 x 3/8)	1
4	BH-3803	Contactor Assembly	1
	BH-3804	Three Phase 24V Control	
5	BH-2189	Three Phase 115V Control	2
	BH-2161	Pan Head Self Tapping Screw (#8-32 x 1/2)	2
6	BH-2162	Hex Socket Head Cap Screw (#10-24 x 3/8 Pltd.)	2
	BH-2162	Regular Helical Spring Lock Washer (#10 Pltd.)	2
7	See Fig. 9-11	Limit Switch and Shaft Assembly	1
	BH-2166	Transformer	1
9	BH-2166	Three Phase 208V/24V	
	BH-2164	Three Phase 230V/24V	
	BH-2167	Three Phase 460V/24V	
	BH-2168	Three Phase 575V/24V	
	BH-2169	Three Phase 208/115V	
	BH-2170	Three Phase 230V/115V	
	BH-2171	Three Phase 460V/115V	
BH-2172	Three Phase 575V/115V		
10	BH-2173	Sems Round Head Machine Screw with External Lock	1
	BH-2173	Washer (1/4-20 x 5/8)	2
11	BH-2174	Plain Washer (Type N 1/4)	1
	See Fig. 9-13	Push Button Station and Conductor Cable Assembly	1

(Continued on following page)

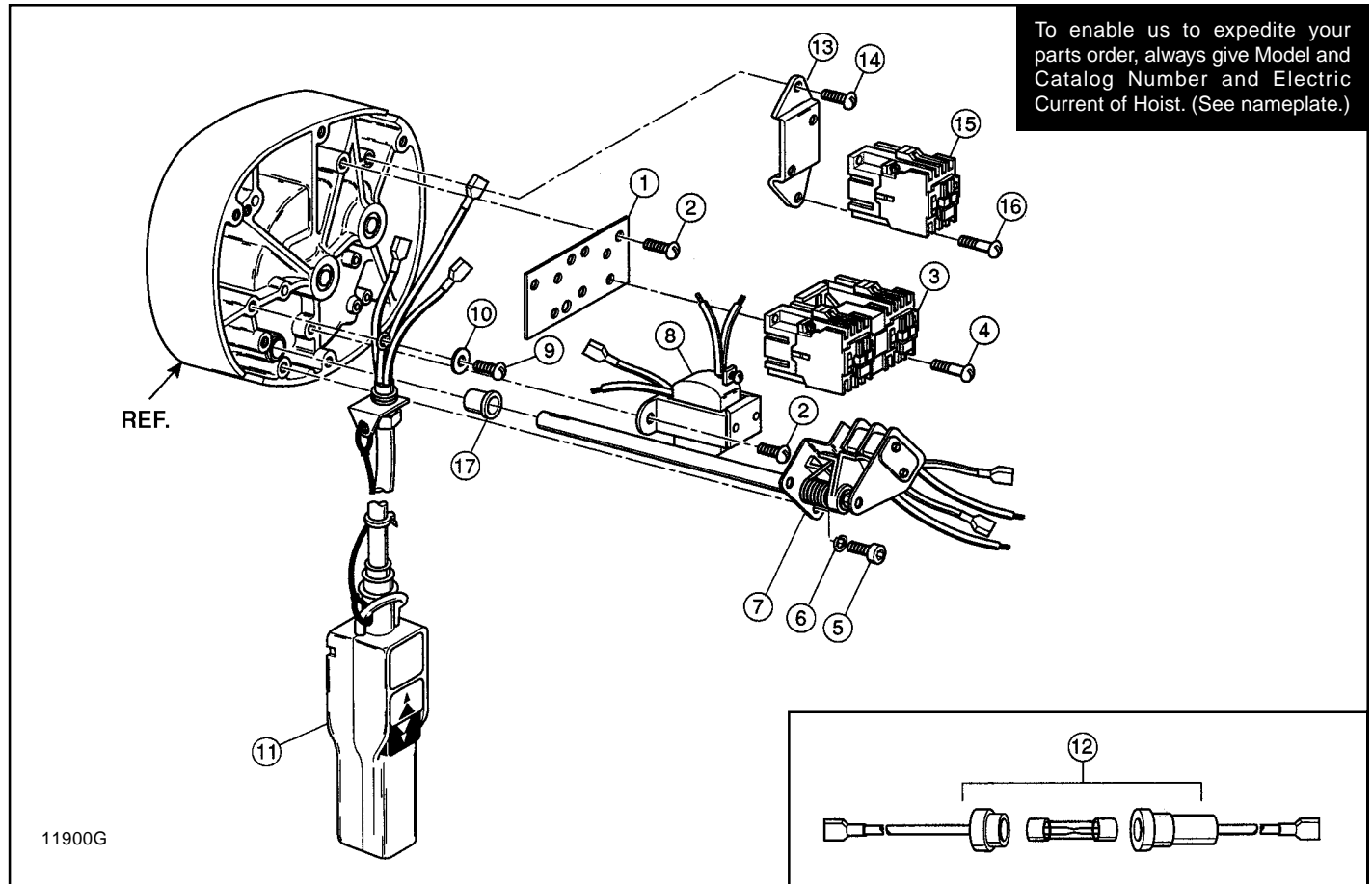

Figure 9-9. ELECTRICAL CONTROL UNITS (Two Speed Hoists Only - Earlier Version)

Ref. No.	Part Number	Description	Qty. Req'd
		Contactor and Mounting Plate Assembly (Includes Ref. Nos. 1, 3 and 4)	1
	BH-2150	Three Phase 24V Control	
	BH-2151	Three Phase 115V Control	
1	BH-2154	Mounting Plate - Contactor	1
2	BH-2155	Sems Round Head Machine Screw with External Lock Washer (#10-24 x 3/8)	4
3		Contactor Assembly	1
	BH-2156	Three Phase 24V Control	
	BH-2157	Three Phase 115V Control	
4	BH-2160	Round Head Machine Screw (#8-32 x 1/2)	2
5	BH-2161	Hex Socket Head Cap Screw (#10-24 x 3/8 Pltd.)	2
6	BH-2162	Regular Helical Spring Lock Washer (#10 Pltd.)	2
7	See Fig. 9-11	Limit Switch and Shaft Assembly	1
8		Transformer	1
	BH-2166	Three Phase 200V/24V	
	BH-2164	Three Phase 230V/24V	
	BH-2167	Three Phase 460V/24V	
	BH-2168	Three Phase 575V/24V	
	BH-2169	Three Phase 200V/115V	
	BH-2170	Three Phase 230V/115V	
	BH-2171	Three Phase 460V/115V	
	BH-2172	Three Phase 575V/115V	
9	BH-2173	Sems Round Head Machine Screw with External Lock Washer (1 /4-20 x 5/8)	1
10	BH-2174	Plain Washer (Type N 1/4)	1
11	See Fig. 9-13	Push Button Station and Conductor Cable Assembly	1

(Continued on following page)

To enable us to expedite your parts order, always give Model and Catalog Number and Electric Current of Hoist. (See nameplate.)

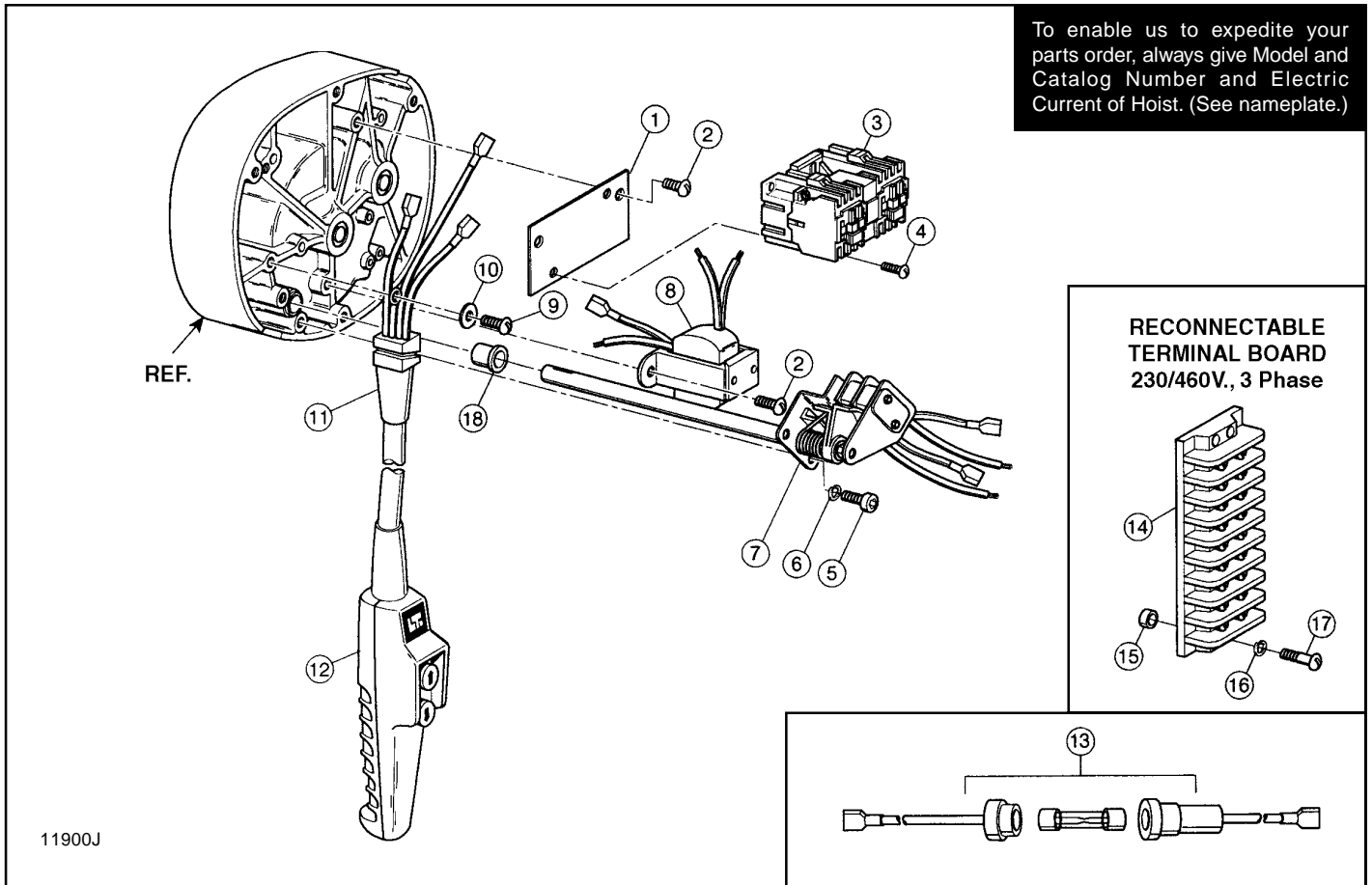

Figure 9-10A. ELECTRICAL CONTROL UNITS (Single Phase Hoists - Later Version)

Ref. No.	Part Number	Description	Qty. Req'd		
1	BH-3800	Contractor and Mounting Plate Assembly (Includes Ref. Nos. 1, 3 and 4) 1/4, 1/2 & 1 HP Single Phase 24V Control	1		
	BH-3801	Single Phase 115V Control			
	BH-3814	2-1/4 HP Only Single Phase 24V Control			
	BH-3815	Single Phase 115V Control			
	BH-3802	Mounting Plate - Contactor			
	2	BH-2155		Sems Round Head Machine Screw with External Lock Washer (#10-24 x 3/8)	
	3			Contactor Assembly 1/4, 1/2 & 1 HP Single Phase 24V Control	1
		BH-3803		Single Phase 115V Control	
		BH-3804		2-1/4 HP Only Single Phase 24V Control	
BH-3816		Single Phase 115V Control			
BH-3817					
4		BH-2189	Pan Head Self Tapping Screw (#8-32 x 1/2)	2	
		BH-2161	Hex Socket Head Cap screw (#10-24 x 3/8 Pltd.)		
5	BH-2162	Regular Helical Spring Lock Washer (#10 Pltd.)	2		
7	See Fig. 9-11	Limit Switch and Shaft Assembly	1		
8		Transformer	1		
9	BH-3818	Single Phase 115V/230V/24V	1		
	BH-3819	Single Phase 115V/230V/115V			
	BH-2173	Sems Round Head Machine Screw with External Lock Washer (1/4-20 x 5/8)			

(Continued on following page)

To enable us to expedite your parts order, always give Model and Catalog Number and Electric Current of Hoist. (See nameplate.)

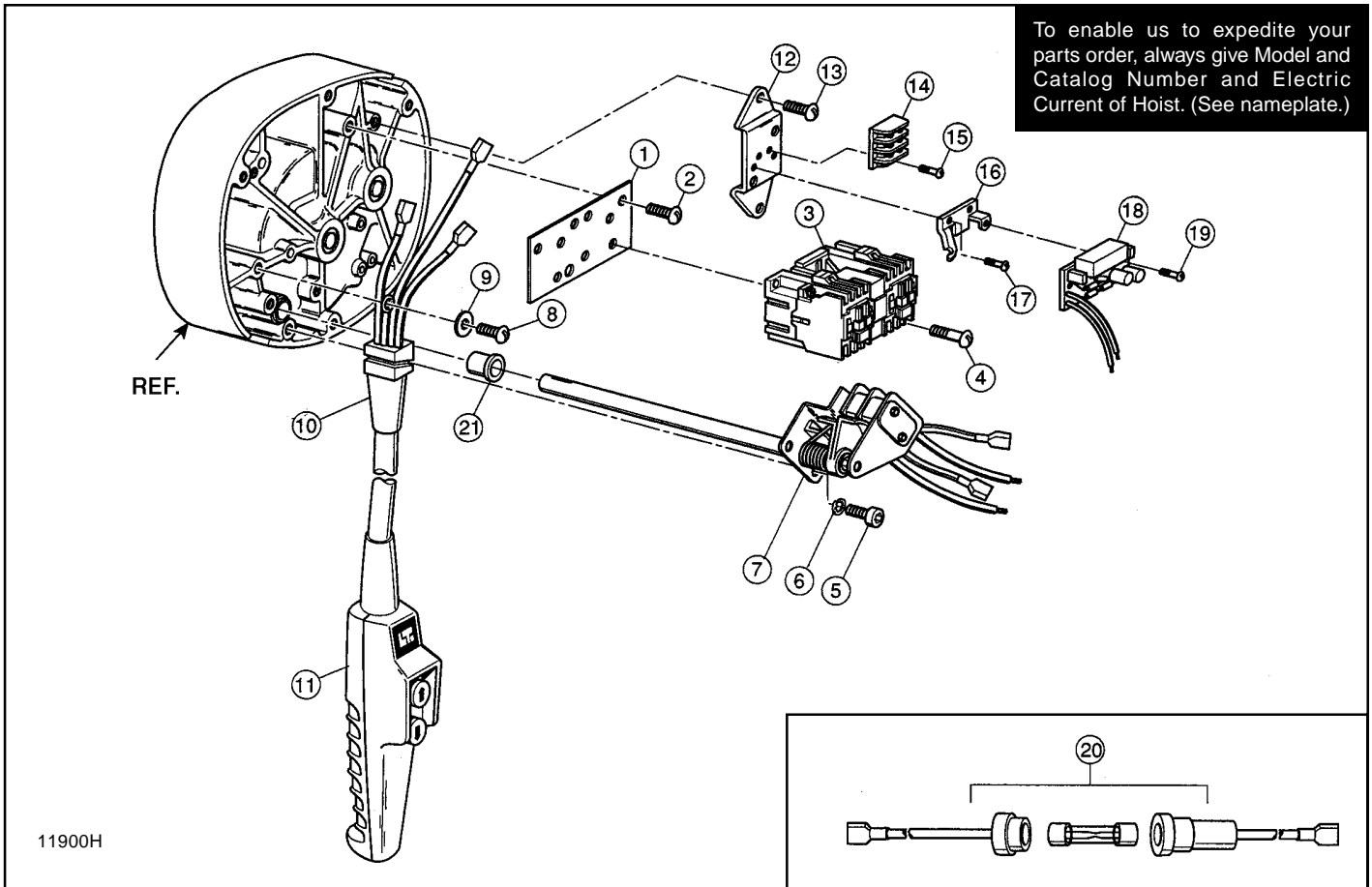

Figure 9-10. ELECTRICAL CONTROL UNITS (Single Phase Hoists - Earlier Version)

Ref. No.	Part Number	Description	Qty. Req'd
	BH-3101	Contactor and Mounting Plate Assembly (Includes Ref. Nos. 1, 3 and 4)	1
1	BH-2154	Mounting Plate-Contactor	1
2	BH-2155	Sems Round Head Machine Screw with External Lock Washer (#10-24 x 3/8)	4
3	BH-3102	Contactor Assembly	1
4	BH-3103	Pan Head Self Tapping Screw (#8-32 x 1/2 Pltd.)	2
5	BH-2161	Hex Socket Head Cap Screw (#10-24 x 3/8 Pltd.)	2
6	BH-2162	Regular Helical Lock Washer (#10 Pltd.)	2
7	See Fig. 9-11	Limit Switch and Shaft Assembly	1
8	BH-2173	Sems Round Head Machine Screw with External Lock Washer (1/4-20 x 5/8)	1
9	BH-2174	Plain Washer (Type N 1/4)	1
10	BH-2175	Grommet	1
11	See Fig. 9-12	Push Button Station and Conductor Cable Assembly	1
12	BH-3104	Mounting Plate-Terminal Board	1
13	BH-3105	Pan Head Self Tapping Screw (#10-24 x 3/8 Pltd.)	2
14	BH-3106	Terminal Block	1
15	BH-3107	Pan Head Self Tapping Screw (8-32 x 1/2 Pltd.)	2
16	BH-3108	Mounting Bracket-Starting Switch	1
17	BH-3109	Pan Head Self Tapping Screw (#6-32 x 3/8 Pltd.)	2
18		Starting Switch	1
	BH-3110	1/4 Horsepower	
	BH-3111	1/2 Horsepower	
	BH-3112	1 Horsepower	
19	BH-3113	Round Head Machine Screw (#6-32 x 5/16 Pltd.)	1
20	BH-3114	Fuse, Fuse Holder and Wire Assembly (1/2A/250V)	1
	BH-3115	Fuse Only (1/2A/250V Rating)	1
21	BH-1422	Flanged Sleeve Bearing	1

Note: Replacement fuses are standard automotive type and may be purchased locally.

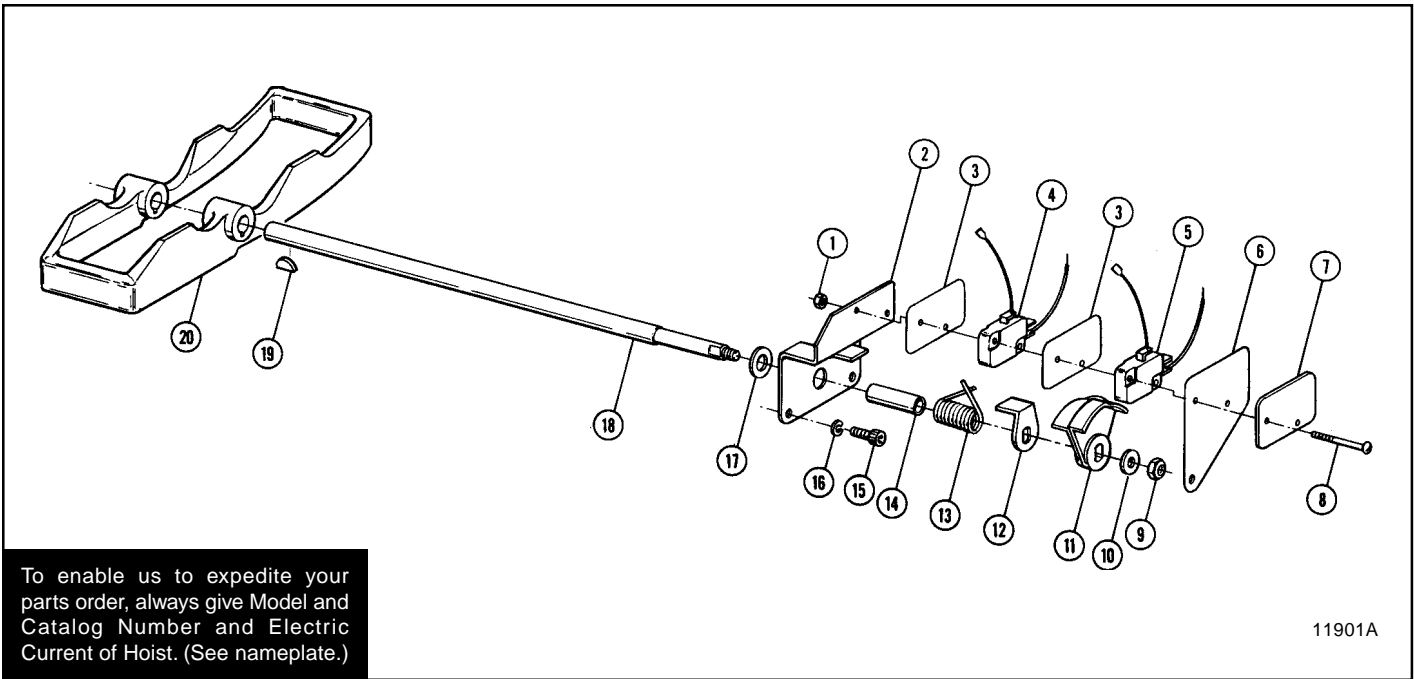

Figure 9-11. LIMIT LEVER AND SWITCH PARTS

Ref. No.	Part Number	Description	Qty. Req'd
	BH-1850	Limit Switch and Shaft Assembly (Includes Ref. Nos. 1 thru 14 and 17 and 18)	1
1	BH-1851	Light Hex Self-locking Nut (#4-40 Pltd.)	2
2	BH-1852	Retainer	1
3	BH-1853	Insulation	2
4	BH-1854	Limit Switch-Upper	1
5	BH-1855	Limit Switch-Lower	1
6	BH-1856	Insulation	1
7	BH-1857	Plate-Cover	1
8	BH-1858	Round Head Machine Screw (#40-40 x 1-1/8 Pltd.)	2
9	BH-1859	Light Thin Hex Self-locking Nut (#10-24 Pltd.)	1
10	BH-1860	Plain Washer (#10 Pltd.)	1
11	BH-1861	Switch Actuator	1
12	BH-1862	Centering Lever	1
13	BH-1863	Spring-Control	1
14	BH-1864	Spacer	1
15	BH-1865	Hex Socket Head Cap Screw (#10-24 x 3/8 Pltd.)	2
16	BH-1866	Regular Helical Spring Lock Washer (#10 Pltd.)	2
17	BH-1867	Plain Washer (Type N 5/16 Pltd.)	1
18	BH-1868	Control Shaft	1
19	BH-1869	Key-Woodruff	1
20	BH-1870	Limit Lever	1

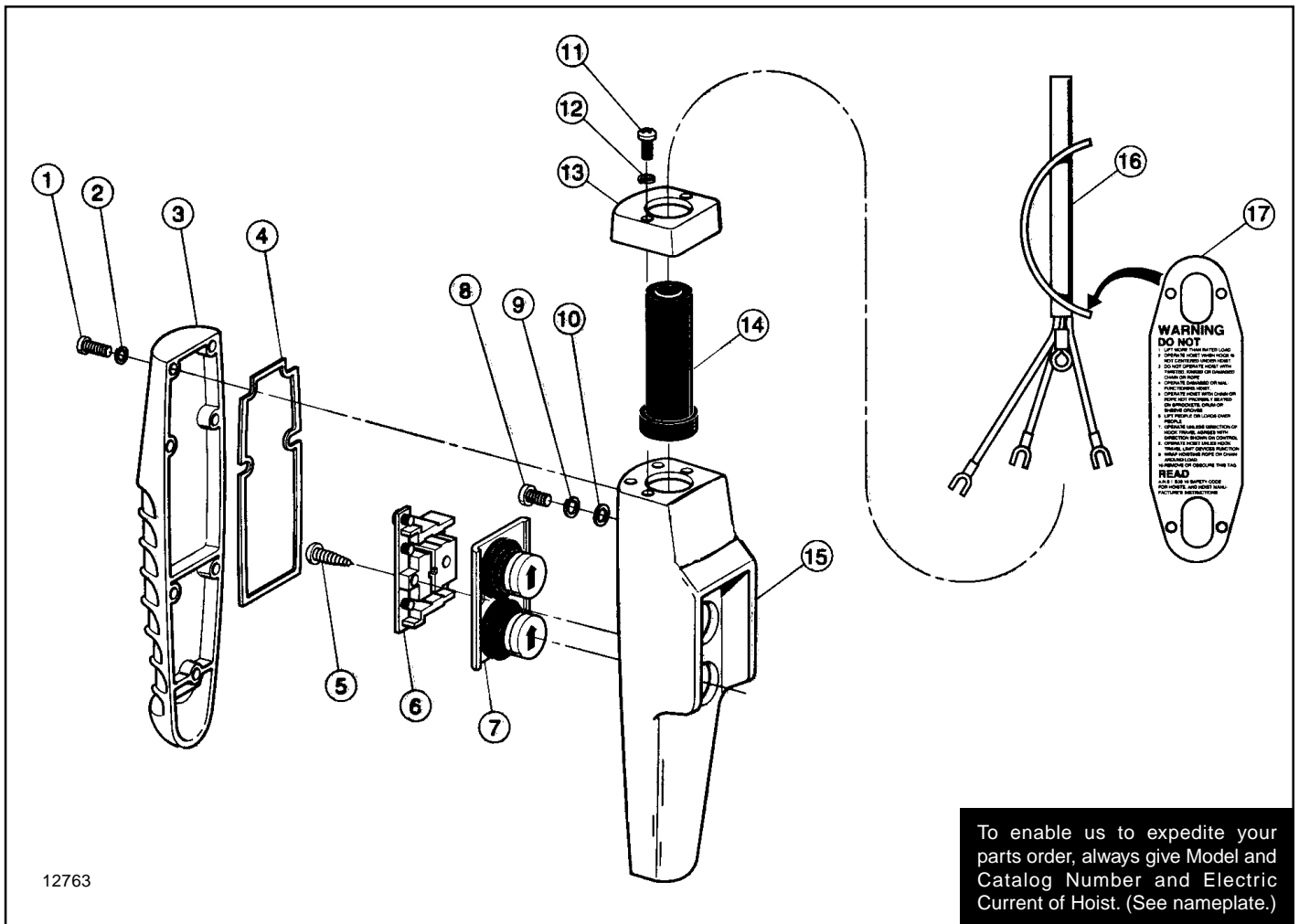
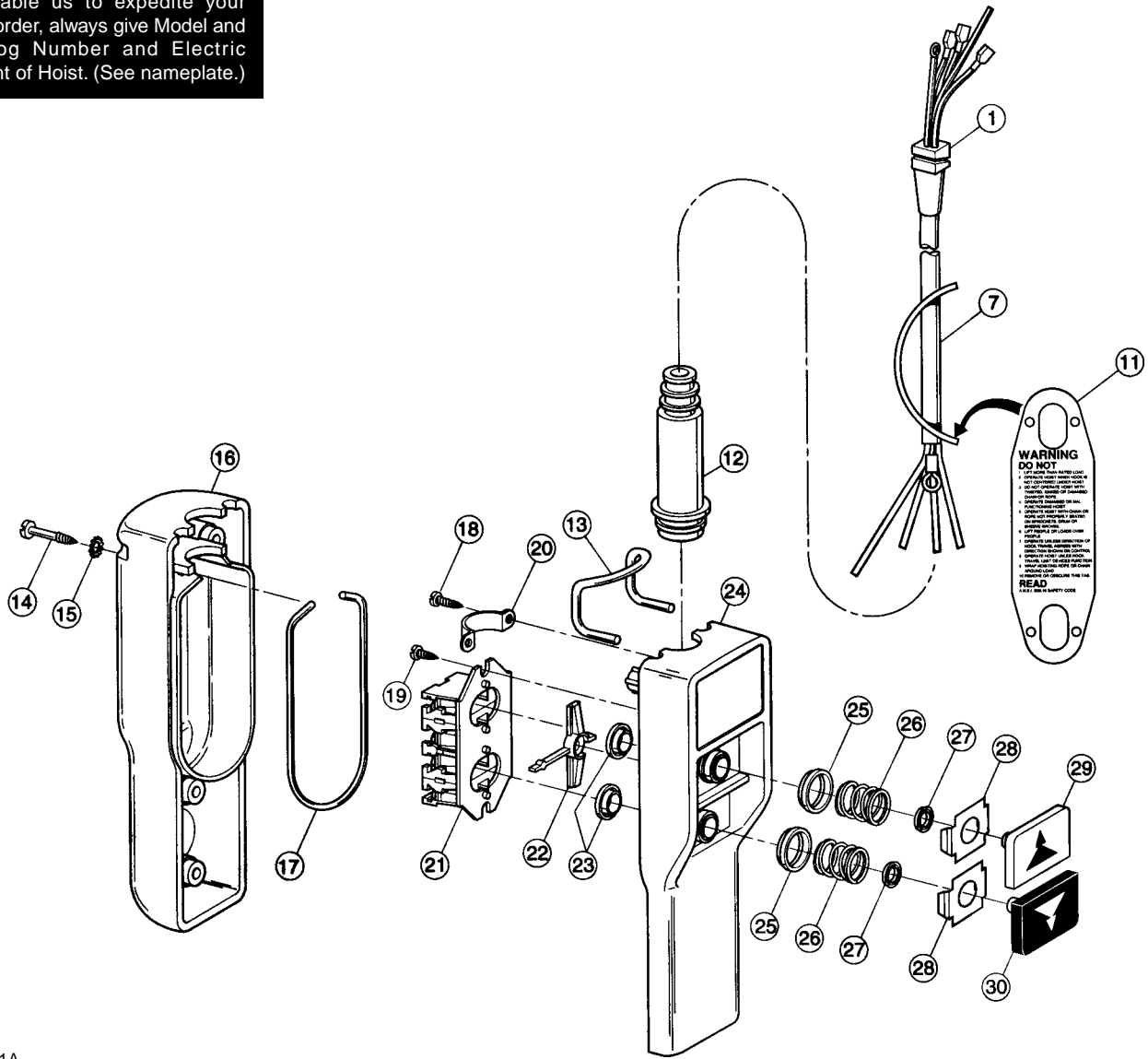

Figure 9-12. PUSH BUTTON STATION AND CONDUCTOR CABLE ASSEMBLY (Single Speed Hoists)

Ref. No.	Part Number	Description	Qty. Req'd
	BH-3401	Push Button Station and Conductor Cable Assembly (Includes Ref. Nos. 1 thru 17)	1
	BH-3402	Push Button Station (Includes Ref. Nos. 1 thru 15)	1
1	*	Type 1 Pan Head Machine Screw (M3.5 x 0.6 x 12 Pltd.)	7
2	*	Lockwasher (M 3.5 Pltd.)	7
3	*	Rear Cover	1
4	BH-3403	Gasket	1
5	*	Type I Pan Head Thread Cutting Screw (M 4 x 15 Pltd.)	2
6	BH-3404	Contact Assembly	1
7	BH-3405	Button Assembly	1
8	*	Type 1 Pan Head Machine Screw (M 6 x 1 x 12 Pltd.)	1
9	*	Lockwasher (M 6 Pltd.)	1
10	*	Plain Washer (M 6 Pltd.)	1
11	*	Type 1 Pan Head Machine Screw (M 3.5 x 1 x 14 Pltd.)	2
12	*	Lockwasher (M 3.5 Pltd.)	2
13	*	Housing Cap	1
14	BH-3406	Grommet	1
15	*	Housing	1
16	BH-3407	Conductor Cable Assembly	1
17	BH-3408	Plastic Warning Tag	1

* Not available separately. Order Push Button Station.

To enable us to expedite your parts order, always give Model and Catalog Number and Electric Current of Hoist. (See nameplate.)



12721A

**Figure 9-13A. PUSH BUTTON STATION AND CONDUCTOR CABLE ASSEMBLY
(Two Speed Hoists Only - Later Version)**

Ref. No.	Part Number	Description	Qty. Req'd
	BH-1980	Push Button Station and Conductor Cable Assembly (Includes Ref. Nos. 1 thru 30)	1
1	BH-1981	Grommet	1
7	BH-1982	Conductor Cable	1
11	BH-1971	Operator Warning Label	1
	BH-1972	Push Button Station (Includes Ref. Nos. 12 thru 30)	1
12	BH-1973	Sleeve - Conductor	1
13	*	Support - Strain Cable	1
14	*	Screw - Slotted Head	4
15	*	Lockwasher	4
16	*	Enclosure - Rear	1
17	*	Gasket	1
18	*	Screw - Slotted Head	2
19	*	Screw - Slotted Head	2
20	*	Clamp - Conductor	1

(Continued on following page)

To enable us to expedite your parts order, always give Model and Catalog Number and Electric Current of Hoist. (See nameplate.)

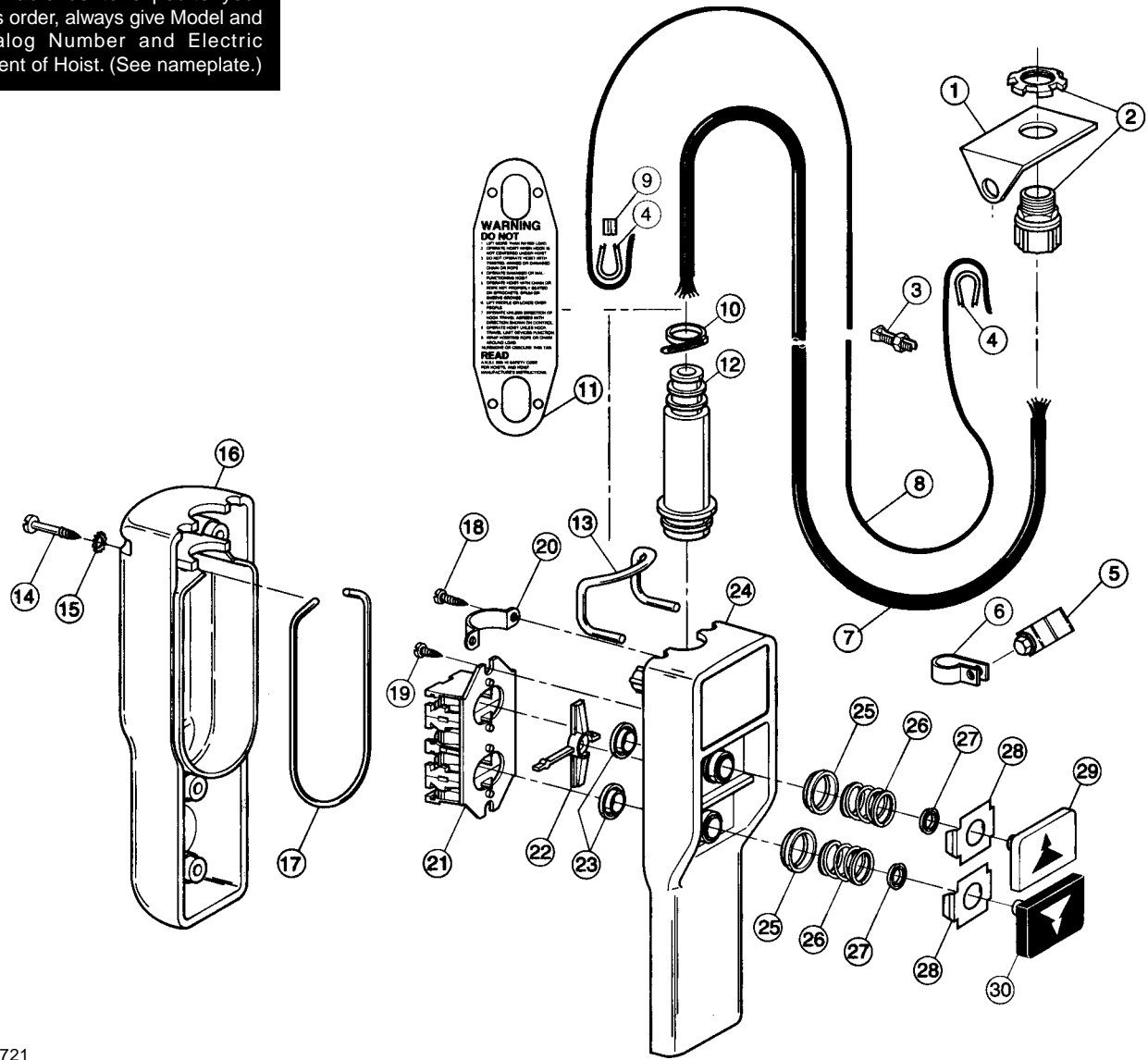

12721

**Figure 9-13. PUSH BUTTON STATION AND CONDUCTOR CABLE ASSEMBLY
(Two Speed Hoists Only - Earlier Version)**

Ref. No.	Part Number	Description	Qty. Req'd
	BH-1960	Push Button Station and Conductor Cable Assembly (Includes Ref. Nos. 1 thru 30)	1
1	BH-1961	Anchor Bracket-Strain Cable	1
2	BH-1962	Grip Assembly-Conductor	1
3	BH-1963	Connector-Strain Cable	1
4	BH-1964	Thimble-Strain Cable	2
5	BH-1965	Connector-Conductor to Strain Cable	1
6	BH-1966	Clamp-Conductor	1
7	BH-1967	Conductor Cable	1
8	BH-1968	Strain Cable	1
9	BH-1969	Sleeve-Pressure	1
10	BH-1970	Tie-Conductor	As Req'd.
11	BH-1971	Operator Warning Label	1
	BH-1972	Push Button Station (Includes Ref. Nos. 12 thru 30)	1

(Continued on following page)

To enable us to expedite your parts order, always give Model and Catalog Number and Electric Current of Hoist. (See nameplate.)

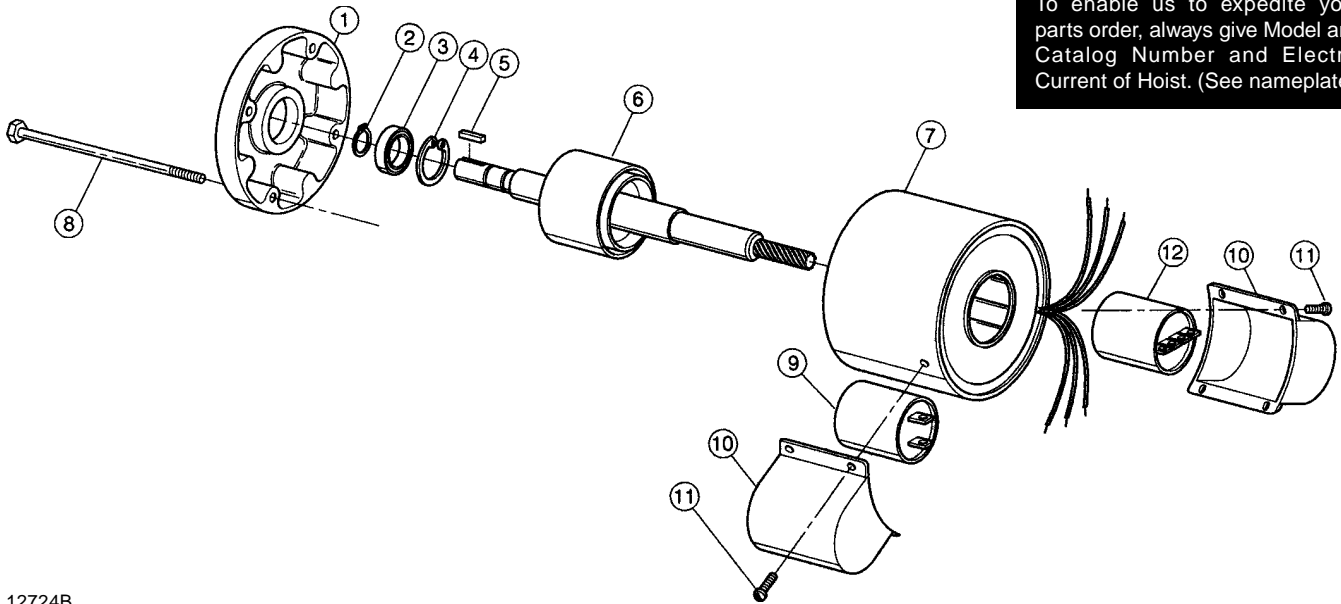

12724B

Figure 9-14A. SINGLE PHASE MOTOR ASSEMBLY - Later Version

Ref. No.	Part Number	Description	Qty. Req'd
		Motor Assembly (Includes Ref. Nos. 1 thru 12)	1
	BH-3900	1/4 Horsepower	
	BH-3901	1/2 Horsepower	
	BH-3902	1 Horsepower	
	BH-3903	2-1/4 Horsepower	
1	BH-3904	Bell - End	1
2	BH-3905	Ring - Retaining	1
3	BH-3906	Bearing - Ball	1
4	BH-3907	Ring - Retaining	1
5	BH-3908	Key - Brake	1
6	*	Rotor and Shaft Assembly	1
7	*	Stator Assembly	1
8		Bolt - Motor Mounting	4
	BH-3909	1/4 Horsepower	
	BH-3910	1/2 Horsepower	
	BH-3911	1 Horsepower	
	BH-3912	2-1/4 Horsepower	
9		Capacitor Assembly	1
	BH-3913	1/4 Horsepower	
	BH-3914	1/2 Horsepower	
	BH-3915	1 Horsepower	
	BH-3916	2-1/4 Horsepower	
10		Cover	1
		For Ref. No. 9	
	BH-3917	1/4 Horsepower	
	BH-3918	1/2 Horsepower	
	BH-3919	1 Horsepower	
	BH-3919	2-1/4 Horsepower	
	BH-3919	For Ref. No. 12	
11	BH-3920	Slotted Hex Head Self Tapping Screw (#8-32 x 5/16)	2
12		Solid State Switch Assembly	1
	BH-3921	1/4, 1/2 & 1 Horsepower	
	BH-3922	2-1/4 Horsepower	

* Furnished only as part of motor assembly.

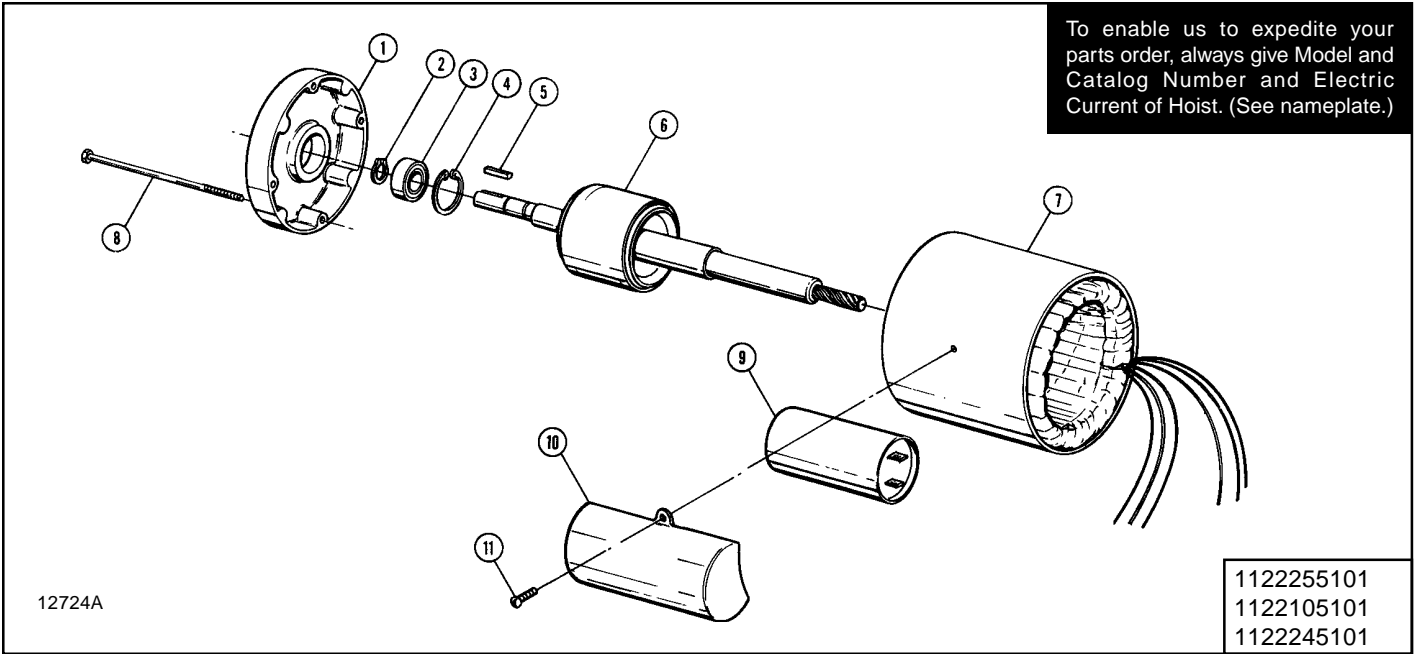

Figure 9-14. SINGLE PHASE MOTOR ASSEMBLY - (Earlier Version)

Ref. No.	Part Number	Description	Qty. Req'd
		Motor Assembly (Includes Ref. Nos. 1 thru 11)	1
	BH-3001	1/4 Horsepower	
	BH-3002	1/2 Horsepower	
	BH-3003	1 Horsepower	
1	BH-3004	Bell-End	1
2	BH-3005	Ring-Retaining	1
3	BH-3006	Bearing-Ball	1
4	BH-3007	Ring-Retaining	1
5	BH-3008	Key-Brake	1
6	*	Rotor and Shaft Assembly	1
7	*	Stator Assembly	1
8		Bolt-Motor Mounting	4
	BH-3015	1/4 Horsepower	
	BH-3016	1/2 Horsepower	
	BH-3017	1 Horsepower	
9	BH-3018	Capacitor Assembly	1
10	BH-3019	Capacitor Cover	1
11	BH-3020	Screw	2

* Furnished only as part of motor assembly.

NOTES

To enable us to expedite your parts order, always give Model and Catalog Number and Electric Current of Hoist. (See nameplate.)

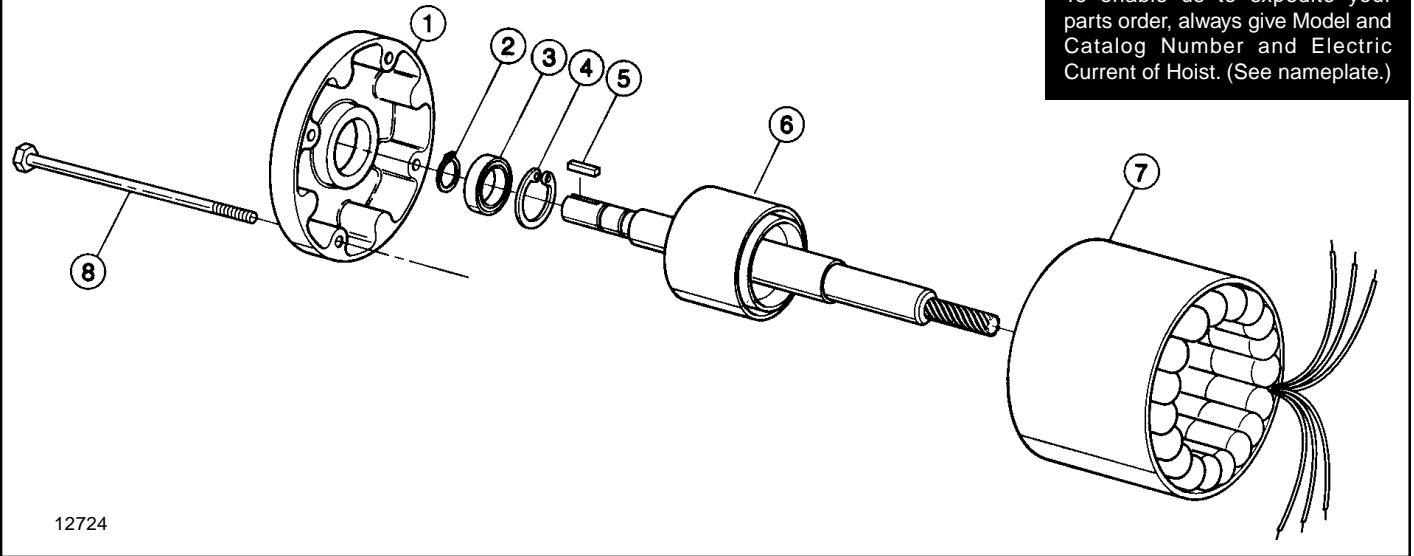

12724

Figure 9-15. THREE PHASE MOTOR ASSEMBLY

Ref. No.	Part Number	Description	Qty. Req'd
		Motor Assembly (Includes Ref. Nos. 1 thru 8)	
		1/4 Horsepower (1 Speed)	1
	BH-3301	200 Volt	
	BH-3302	230/460 Volt	
	BH-3303	575 Volt	
		1/2 Horsepower (1 Speed)	
	BH-3304	200 Volt	
	BH-3305	230/460 Volt	
	BH-3306	575 Volt	
		1 Horsepower (1 Speed)	
	BH-3307	200 Volt	
	BH-3308	230/460 Volt	
	BH-3309	575 Volt	
		2-1/2 Horsepower (1 Speed)	
	BH-2945	200 Volt	
	BH-2946	230/460 Volt	
	BH-2947	575 Volt	
		1/2-1/6 Horsepower (2 Speed)	
	BH-2901	200 Volt	
	BH-2902	230 Volt	
	BH-2903	460 Volt	
	BH-2904	575 Volt	
		1-1/3 Horsepower (2 Speed)	
	BH-2905	200 Volt	
	BH-2906	230 Volt	
	BH-2907	460 Volt	
	BH-2908	575 Volt	
		2-1/4 - 3/4 Horsepower (2 Speed)	
	BH-2909	200 Volt	
	BH-2910	230 Volt	
	BH-2911	460 Volt	
	BH-2912	575 Volt	
1		Bell - End	1
	BH-3310	1 Speed - 1/4, 1/2 and 1 HP	
	BH-2913	1 Speed - 2-1/2 HP	
	BH-2913	2 Speed	

(Continued on following page)

Figure 9-15. THREE PHASE MOTOR ASSEMBLY - Continued

Ref. No.	Part Number	Description	Qty. Req'd
2	BH-3311	Ring - Retaining 1 Speed- 1/4, 1/2 and 1 HP	1
	BH-2914	1 Speed - 2-1/2 HP	
	BH-2914	2 Speed	
3		Bearing - Ball	1
	BH-3312	1 Speed - 1/4, 1/2 and 1 HP	
	BH-2915	1 Speed - 2-1/2 HP	
	BH-2915	2 Speed	
4		Ring - Retaining	1
	BH-3313	1 Speed - 1/4, 1/2 and 1 HP	
	BH-2916	1 Speed - 2-1/2 HP	
	BH-2916	2 Speed	
5		Key - Brake	1
	BH-3314	1 Speed - 1/4, 1/2 and 1 HP	
	BH-2917	1 Speed - 2-1/2 HP	
	BH-2917	2 Speed	
6	*	Rotor and Shaft Assembly	1
7	*	Stator Assembly	1
8		Bolt - Motor Mounting	4
	BH-3315	1 Speed - 1/4, 1/2 and 1 HP	
	BH-2954	1 Speed - 2-1/2 HP	
	BH-2942	2 Speed	

* Furnished only as part of motor assembly.

NOTES

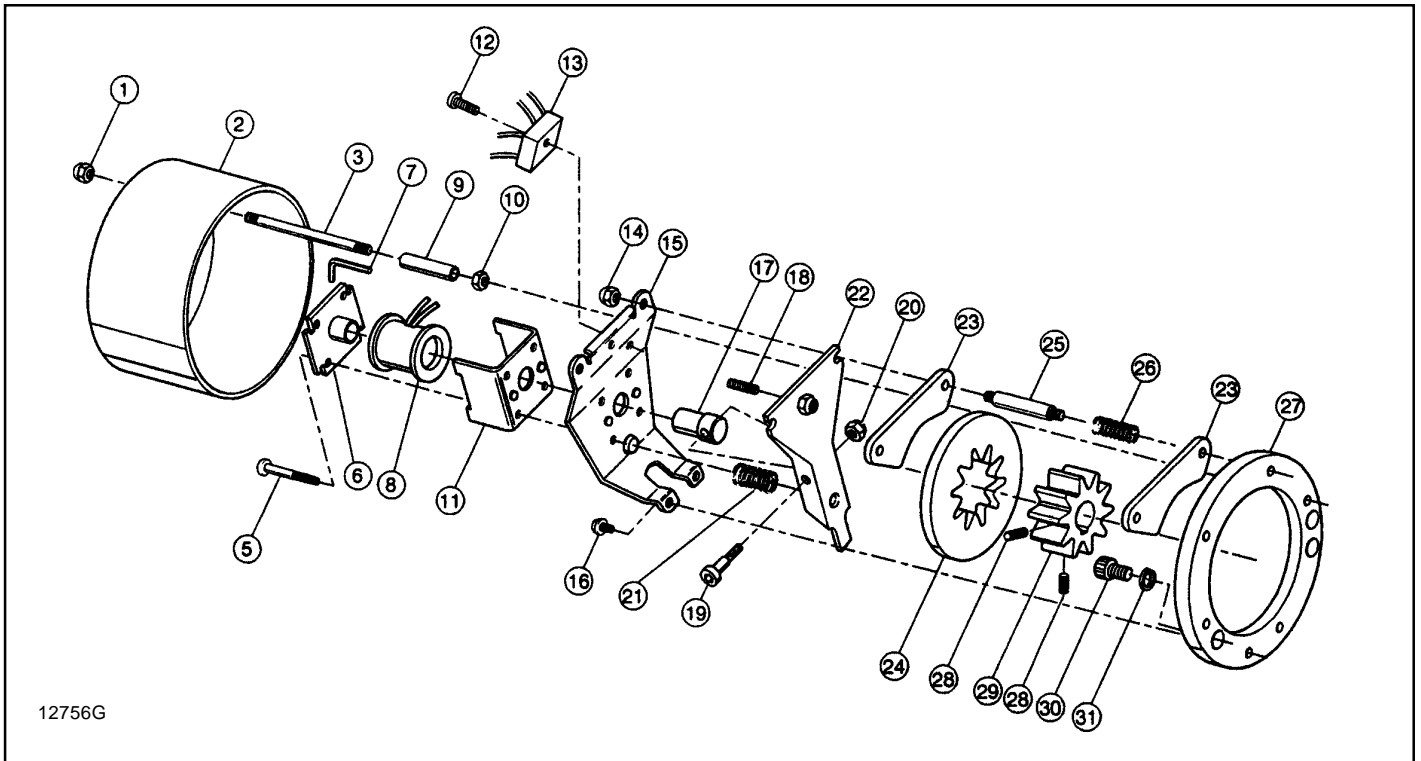

Figure 9-16A. HOIST MOTOR BRAKE

Ref. No.	Part Number	Description	Qty. Req'd																																																																
		Motor Brake Assembly (Includes Ref. Nos. 1 thru 31)																																																																	
		<table border="0"> <tr> <td>Hoist Speeds</td> <td>Motor HP</td> <td>Voltage</td> <td></td> </tr> <tr> <td>BH-3701</td> <td>1</td> <td>1/4, 1/2 & 1</td> <td>1</td> </tr> <tr> <td></td> <td>1</td> <td>2-1/2</td> <td></td> </tr> <tr> <td></td> <td>2</td> <td>1 / 1/3</td> <td></td> </tr> <tr> <td></td> <td>2</td> <td>2-1/4 / 3/4</td> <td></td> </tr> <tr> <td>BH-3702</td> <td>1</td> <td>1/4 & 1/2</td> <td></td> </tr> <tr> <td></td> <td>1</td> <td>1</td> <td></td> </tr> <tr> <td></td> <td>1</td> <td>2-1/2</td> <td></td> </tr> <tr> <td></td> <td>2</td> <td>1/2 / 1/6</td> <td></td> </tr> <tr> <td></td> <td>2</td> <td>1 / 1/3</td> <td></td> </tr> <tr> <td></td> <td>2</td> <td>2-1/4 / 3/4</td> <td></td> </tr> <tr> <td>BH-3703</td> <td>1</td> <td>1/4 & 1/2</td> <td></td> </tr> <tr> <td></td> <td>2</td> <td>1/2 / 1/6</td> <td></td> </tr> <tr> <td></td> <td>2</td> <td>1 / 1/3</td> <td></td> </tr> <tr> <td>BH-3704</td> <td>1</td> <td>2-1/2</td> <td></td> </tr> <tr> <td>BH-3705</td> <td>1</td> <td>2-1/2</td> <td></td> </tr> </table>	Hoist Speeds	Motor HP	Voltage		BH-3701	1	1/4, 1/2 & 1	1		1	2-1/2			2	1 / 1/3			2	2-1/4 / 3/4		BH-3702	1	1/4 & 1/2			1	1			1	2-1/2			2	1/2 / 1/6			2	1 / 1/3			2	2-1/4 / 3/4		BH-3703	1	1/4 & 1/2			2	1/2 / 1/6			2	1 / 1/3		BH-3704	1	2-1/2		BH-3705	1	2-1/2		
Hoist Speeds	Motor HP	Voltage																																																																	
BH-3701	1	1/4, 1/2 & 1	1																																																																
	1	2-1/2																																																																	
	2	1 / 1/3																																																																	
	2	2-1/4 / 3/4																																																																	
BH-3702	1	1/4 & 1/2																																																																	
	1	1																																																																	
	1	2-1/2																																																																	
	2	1/2 / 1/6																																																																	
	2	1 / 1/3																																																																	
	2	2-1/4 / 3/4																																																																	
BH-3703	1	1/4 & 1/2																																																																	
	2	1/2 / 1/6																																																																	
	2	1 / 1/3																																																																	
BH-3704	1	2-1/2																																																																	
BH-3705	1	2-1/2																																																																	
1	*	Acorn Nut - Plated (#10-32)	2																																																																
2	BH-3706	Brake Cover Assembly (Includes Brake Cover and Label Inside Cover)	1																																																																
3	*	Cover Stud	2																																																																
	*		1																																																																
5	*	Phillips Pan Head Self Tapping Screw- Plated (#10-32 x 1-3/4)	4																																																																
6	*	Solenoid Frame Cover Assembly	1																																																																
7	*	Hex Key (1/8 - 3/4 x 2)	1																																																																
8	*	Solenoid Coil Assembly	1																																																																
		For BH-3701																																																																	
		For BH-3702																																																																	
		For BH-3703																																																																	
		For BH-3704																																																																	
		For BH-3705																																																																	

(Continued on following page)

Figure 9-16A. HOIST MOTOR BRAKE - Continued

Ref. No.	Part Number	Description	Qty. Req'd
9	*	Tubing	3
10	*	Hex Nut - Plated (#10-32)	2
11	*	Solenoid Frame	1
12	*	Hex Washer Head Thread Forming Screw - Plated (#10-32 x 3/4)	1
13	*	Rectifier Assembly	1
14	*	Hex Head Self Locking Nut - Plated (#10-32)	2
15	BH-3707	Solenoid Support	1
16	*	Hex Washer Head Thread Forming Screw - Plated (#10-32 x 3/4)	2
17	*	Solenoid Plunger	1
18	*	Hex Socket Head set Screw- Oval Point (1/4-28 x 1)	1
19**	*	Hex Socket Shoulder Screw (#10-24 x 1)	1
20**	*	Hex Self Locking Nut - Plated (#10-24)	1
21	*	Brake Spring	1
22	*	Brake Lever Assembly	1
23	*	Pressure Pad	2
24	*	Brake Disc (Non-asbestos)	1
25	*	Brake Support Stud	2
26	*	Separating Spring	2
27	BH-3708	Brake Mounting Plate	1
28	*	Hex Socket Head Self Locking Set Screw - Cup Point (1/4-20 x 3/8)	2
29	*	Brake Hub	1
30	*	Hex Socket Head Screw (3/8-16 x 3/4)	2
31	*	Lock Washer (3/8)	2
		Wire Nuts - Not Shown (No. 22 thru 14 AWG)	4

* Not available as individual parts. See replacement kits listed below. Kits include quantities shown above.

** On later model hoists Ref. No. 19 is a hex socket head screw (1/4-20 x 1-1/2) and Ref. No. 20 is a hex self locking nut - plated (1/4-20).

Kit Description	Part Number	Reference Numbers Included
Brake Disc	BH-3709	23, 24, 26
Brake Lever	BH-3710	6, 15, 17, 18, 19, 20, 21 (Zinc Color), 22, Adjusting Screw Label, Brake Adjust Label - Discard Red Spring
Rectifier	BH-3711	12, 13, 4 Wire Nuts
Hardware	BH-3712	1, 3, 4, 5, 7, 9, 10, 12, 16, 18, 20, 25, 28, 30, 31, Instruction Label, Power Warning Label
Brake Hub	BH-3713	28, 29, Hub Drive Key (Shown Elsewhere)
Solenoid	BH-3714	8 (Order Same Part Number)

Recommended Spare Parts for Your Budgit Hoist

Certain parts of your hoist will, in time, require replacement under normal wear conditions. It is suggested that the following parts be purchased for your hoist as spares for future use.

Set of Gaskets	Contactactor
Set of Bearings	Transformer Fuse
Set of Oil Seals	Limit Lever
Lower Block Assembly	Limit Switch Assembly
Load Chain	
Set of Brake Discs for Load Brake	
Set of Brake Discs for Motor Brake	
Push Button Station & Cable Assembly	
Transformer	

Note: When ordering parts always furnish Model and Catalog Number of Hoist and lift of hoist on which the parts are to be used.

Parts for your hoist are available from your local authorized **Budgit** repair station. For the location of your nearest repair station, write:

IN USA

Yale•Lift-Tech

P.O. Box 769
Muskegon, MI 49443-0769

Phone: **800 742-9269**

Fax: **800 742-9270**

WARRANTY

WARRANTY AND LIMITATION OF REMEDY AND LIABILITY

A. Seller warrants that its products and parts, when shipped, and its work (including installation, construction and start-up), when performed, will meet applicable specifications, will be of good quality and will be free from defects in material and workmanship. All claims for defective products or parts under this warranty must be made in writing immediately upon discovery and in any event, within one (1) year from shipment of the applicable item unless Seller specifically assumes installation, construction or start-up responsibility. All claims for defective products or parts when Seller specifically assumes installation, construction or start-up responsibility and all claims for defective work must be made in writing immediately upon discovery and in any event, within one (1) year from completion of the applicable work by Seller, provided; however, all claims for defective products and parts made in writing no later than eighteen (18) months after shipment. Defective items must be held for Seller's inspection and returned to the original f.o.b. point upon request. **THE FOREGOING IS EXPRESSLY IN LIEU OF ALL OTHER WARRANTIES WHATSOEVER, EXPRESS, IMPLIED AND STATUTORY, INCLUDING, WITHOUT LIMITATION, THE IMPLIED WARRANTIES OF MERCHANTABILITY AND FITNESS.**

B. Upon Buyer's submission of a claim as provided above and its substantiation, Seller shall at its option either (i) repair or replace its product, part or work at either the original f.o.b. point of delivery or at Seller's authorized service station nearest Buyer or (ii) refund an equitable portion of the purchase price.

C. This warranty is contingent upon Buyer's proper maintenance and care of Seller's products, and does not extend to normal wear and tear. Seller reserves the right to void warranty in event of Buyer's use of inappropriate materials in the course of repair or maintenance, or if Seller's products have been dismantled prior to submission to Seller for warranty inspection.

D. The foregoing is Seller's only obligation and Buyer's exclusive remedy for breach of warranty and is Buyer's exclusive remedy hereunder by way of breach of contract, tort, strict liability or otherwise. In no event shall Buyer be entitled to or Seller liable for incidental or consequential damages. Any action for breach of this agreement must be commenced within one (1) year after the cause of action has accrued.

BUDGIT®